



VALVES INDEX

SOLENOID AND PNEUMATIC VALVES

LINE 110.....	2.3
LINE 115.....	2.7
LINE 120.....	2.13
LINE 125.....	2.20
LINE 127.....	2.28
LINE 128.....	2.37
LINE 130.....	2.43

MULTIPOLE VALVES

LINE 150.....	2.62
LINE 160.....	2.77

VALVES FOR PANEL MOUNTING ACTUATORS

LINE 100-120-125-127.....	2.86
LINE 100.....	2.89
LINE 120.....	2.90
LINE 125.....	2.91
LINE 127.....	2.92

MANUAL VALVES

LINE 100 M5.....	2.94
LINE 120 ME.....	2.97
LINE 125.....	2.103
LINE 127.....	2.108
LINE 130.....	2.114

MECHANICAL VALVES

LINE 100.....	2.119
LINE 120.....	2.124
LINE 127.....	2.133

PEDAL VALVES

LINE 140.....	2.142
---------------	-------

LINE 110 1/8"-Ø4 | SOLENOID VALVES



GENERAL FEATURES

Construction	poppet type
Body size	25mm
Body material	technopolymer
Single use	YES
Modular use	YES
Available functions	3/2; 2/2 upon request

GENERAL TECHNICAL DATA

Fluid	filtered air with or without lubrication
Installation	any positions
Connections	1/8; AU4
Working Pressure	vacuum - 10 bar
Temperature Range	-5 / +50°C (23 / 122°F) Please note: Below 3°C the air of the circuit must be free from humidity
Reference Flow Rate	P1= 6 bar; Δ P= 1 bar; 55 l/min (orifice 1,3mm)
Manual Override	bistable
Weight	0,08 kg

GUIDE TO REFERENCES

EP110 1/8 3 NC SN OO C

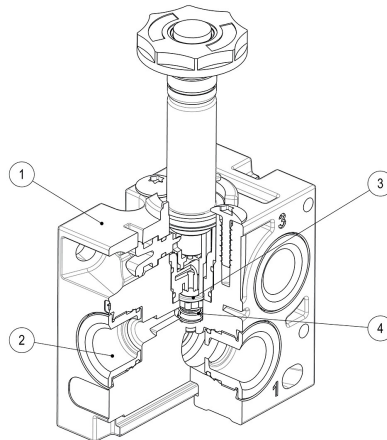
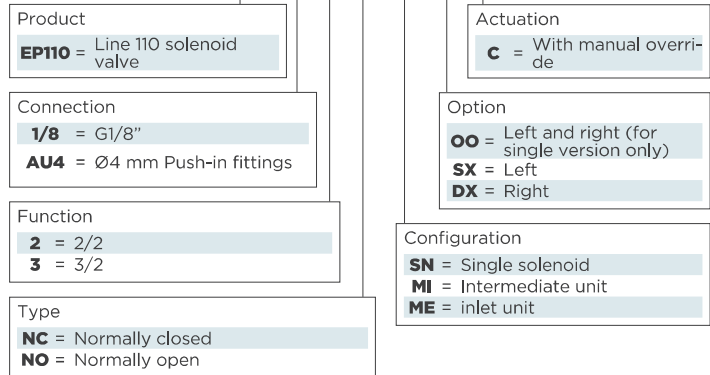

USED MATERIALS

1. **Body Valve** - PBT
2. **Insert** - Brass
3. **Internal Valve** - Brass, NBR
4. **Spring** - Stainless steel

AIR PREPARATION

VALVES

CYLINDERS

FITTINGS

WATER PREPARATION

LINE 110 1/8"-Ø4 | SINGLE SOLENOID VALVE

AIR PREPARATION

VALVES

CYLINDERS

FITTINGS

WATER PREPARATION

SINGLE SOLENOID VALVE

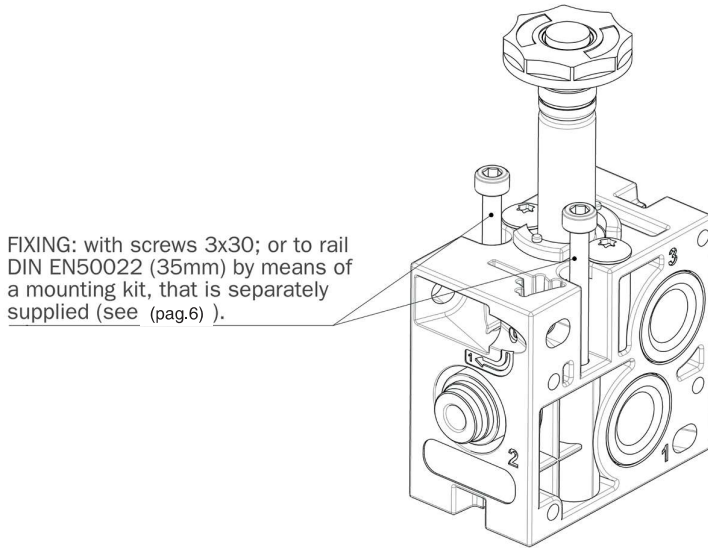

FIXING: with screws 3x30; or to rail DIN EN50022 (35mm) by means of a mounting kit, that is separately supplied (see (pag.6)).

COILS: Available in different voltages (see page 6):
AC 24V, 110V, 220V
DC 12V, 24V



BODY: **00** - with inserts on both sides

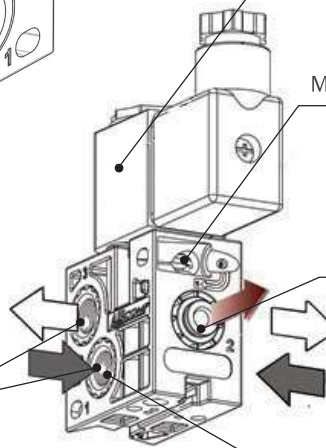

MANUAL ACTUATION: bistable.

OUTLET PORT: available in two versions:
1) **AU4** - push-in fittings Ø4mm
2) **1/8"** - G1/8"

MAX. TORQUE: 1÷1,2 N·m.

ORDER CODES

	DESCRIPTION	CODE	REFERENCES
	3/2 NC G1/8	1103023003	EP110 1/8 3 NC SN OO C
	3/2 NO G1/8	1103023006	EP110 1/8 3 NO SN OO C
	3/2 NC AU4	1103093003	EP110 AU4 3 NC SN OO C
	3/2 NO AU4	1103093006	EP110 AU4 3 NO SN OO C

DIMENSIONS

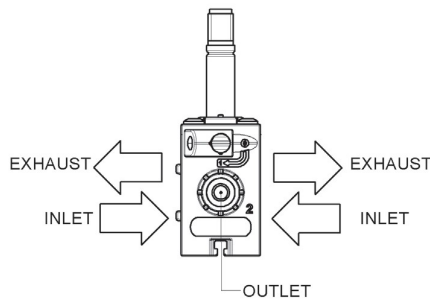
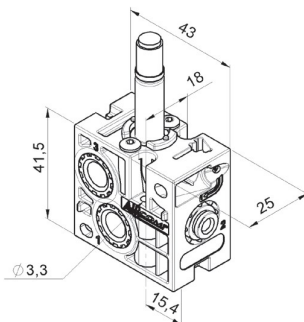

"oo" version
Solenoid valve supplied with two plugs

LINE 110 1/8"-Ø4 | MODULAR SOLENOID VALVE

MODULAR SOLENOID VALVE

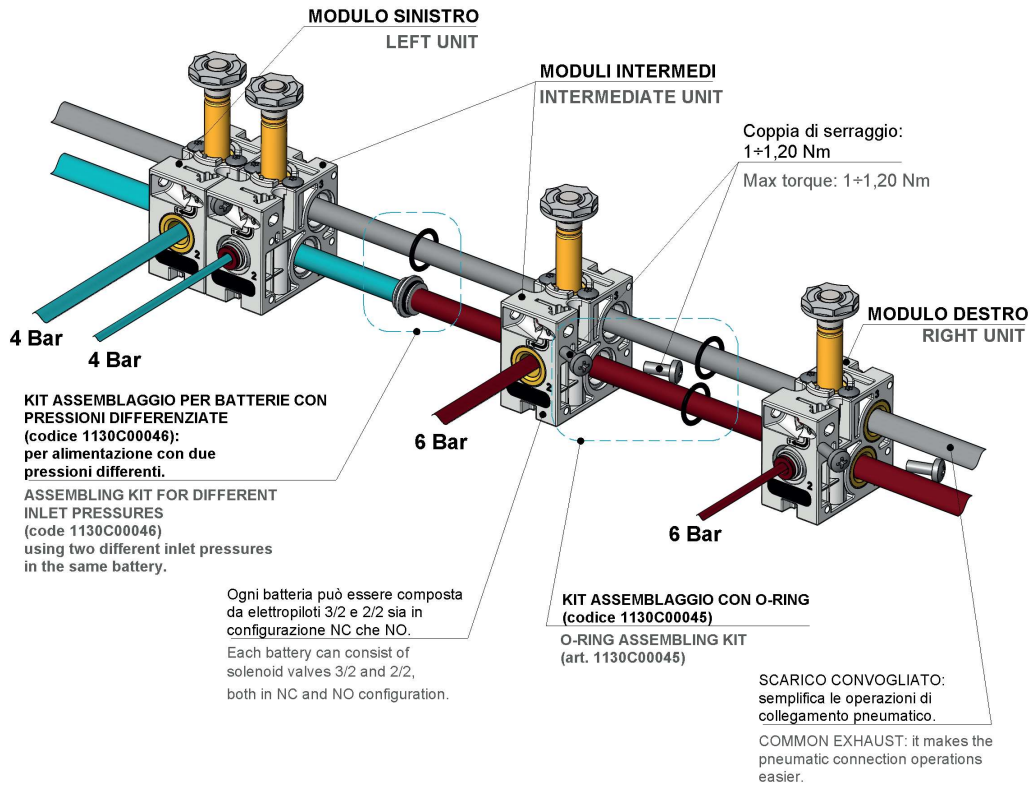

SOLENOID VALVES FOR BATTERY ASSEMBLY

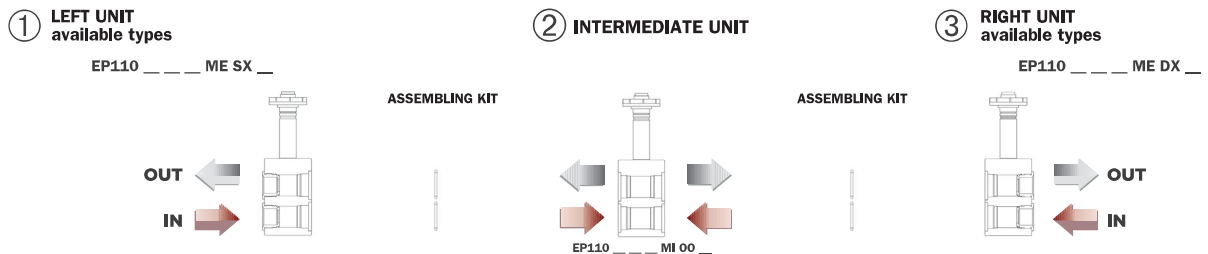

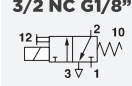
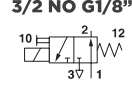
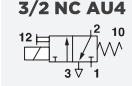
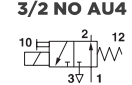
DESCRIPTION	1. LEFT UNIT		2. INTERMEDIATE UNIT		3. RIGHT UNIT	
	CODE	REFERENCES	CODE	REFERENCES	CODE	REFERENCES
 3/2 NC G1/8''	1103023009	EP110 1/8 3 NC ME SX C	1103023007	EP110 1/8 3 NC MI OO C	1103023011	EP110 1/8 3 NC ME DX C
 3/2 NO G1/8''	1103023010	EP110 1/8 3 NO ME SX C	1103023008	EP110 1/8 3 NO MI OO C	1103023012	EP110 1/8 3 NO ME DX C
 3/2 NC AU4	1103093009	EP110 AU4 3 NC ME SX C	1103093007	EP110 AU4 3 NC MI OO C	1103093011	EP110 AU4 3 NC ME DX C
 3/2 NO AU4	1103093010	EP110 AU4 3 NO ME SX C	1103093008	EP110 AU4 3 NO MI OO C	1103093012	EP110 AU4 3 NO ME DX C



1130C0045	Battery assembling kit
1130C0046	Assembling kit for different pressure

LINE 110 1/8"-Ø4 | DIMENSIONS

AIR PREPARATION

VALVES

CYLINDERS

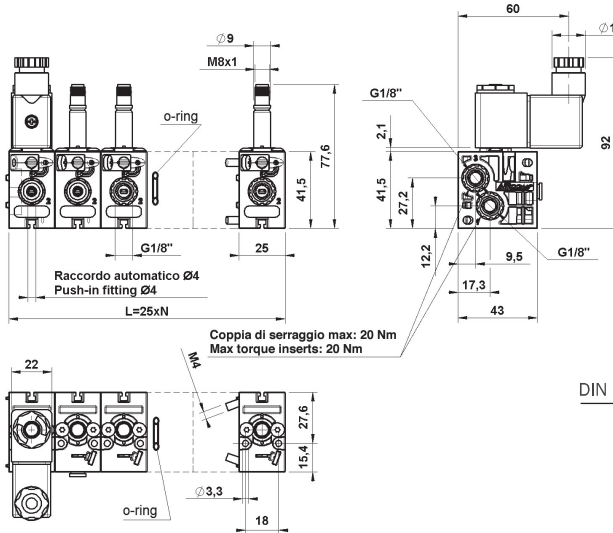

DIN EN50022 rail (35mm).

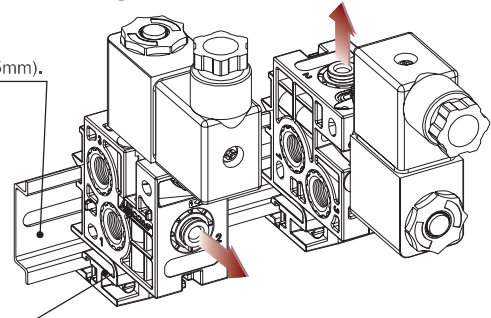

DIN rail mounting kit: it is useful for mounting solenoid valves, either in single or battery configuration, on DIN rail.

Assembling example

FITTINGS

MOUNTING KIT FOR RAIL DIN EN50022 (35MM)

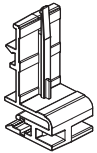

CODE	REF.
1130C00003	Mounting Kit for DIN rail

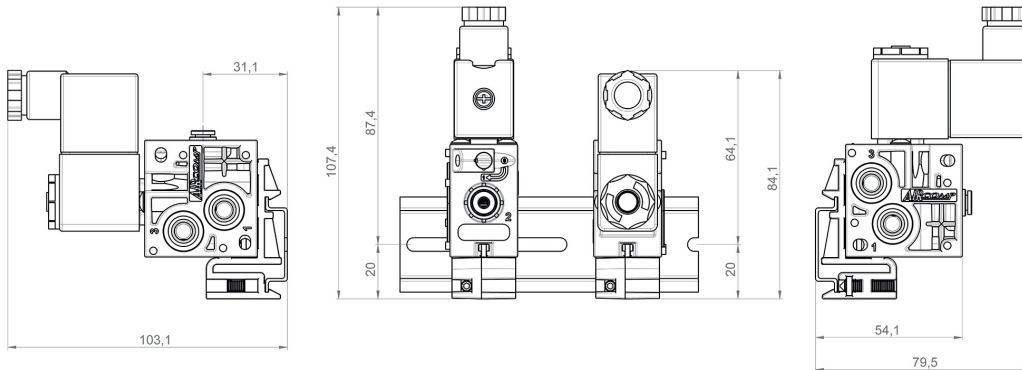

WATER PREPARATION

COIL FIXING UNIT



CODE	REF.
1311A00015	Open fixing nut

CONNECTOR



CODE	REF.
A502600010	CONNECTOR SP. 22mm

COIL 22MM



CODE	REF.
A5002600018	COIL DC12V
A5002600006	COIL DC24V
A5002600007	COIL AC24V 50/60HZ
A5002600008	COIL AC110V 50/60HZ
A5002600009	COIL AC220V 50/60HZ

For led connectors and pre-cabled, please see page 2.60

LINE 115 1/8" | SOLENOID AND PNEUMATIC VALVES

AIR PREPARATION

VALVES

CYLINDERS

FITTINGS

WATER PREPARATION

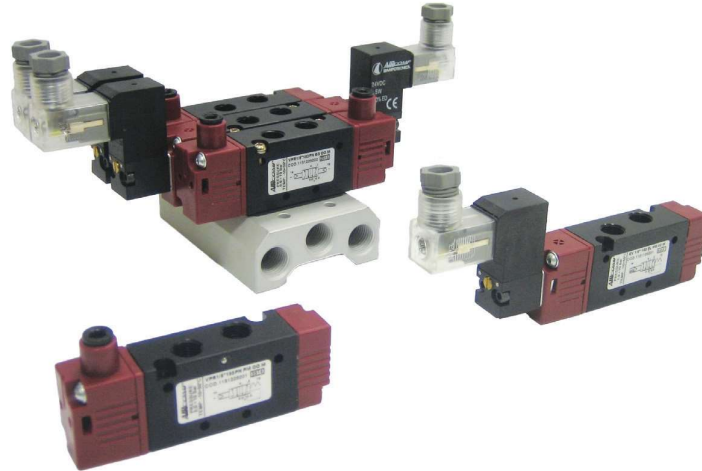

GENERAL FEATURES

Construction	spool valve
Body size	18mm
Body material	aluminium
Single use	YES
Manifold use	YES
Available functions	5/2; 5/3
Valve supplied with coil	

GENERAL TECHNICAL DATA

Fluid	filtered air with or without lubrication
Connections	1/8"
Temperature Range	-5 / +50°C (23 / 122°F) Please note: Below 3°C the air of the circuit must be free from humidity
Reference Flow Rate	P1= 6 bar; Δ P= 1 bar; 5/2 = 550 l/min 5/3 = 500 l/min

GUIDE TO REFERENCES

EVR 1/8" 18 5 SL PM OO M

Option EVR = Solenoid valves VPR = Pneumatic valves	Material M = Metal
Connection 1/8" = G1/8"	Option CC = Closed centres CA = Opened centres CP = Pressure centre OO = 5/2
Size 18 = 18 mm	Return PM = Pneum. mech. spring BS = Bistable RC = Return to centre
Function 5 = 5/2 6 = 5/3	Operation PN = Pneumatic SL = Solenoid SA = Assisted solenoid

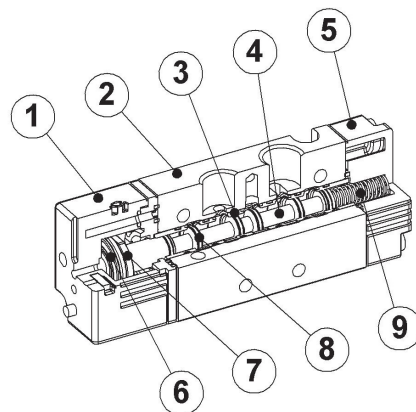

USED MATERIALS

1. Operator body - POM
2. Body valve - Aluminium
3. Spacers - POM
4. Spool - Aluminium
5. Base command - POM
6. Piston gasket - NBR
7. Piston - POM
8. Spool gasket - NBR
9. Spring - Stainless steel

LINE 115 EVR 1/8" | SOLENOID VALVES

AIR PREPARATION

5/2 SINGLE SOLENOID VALVES

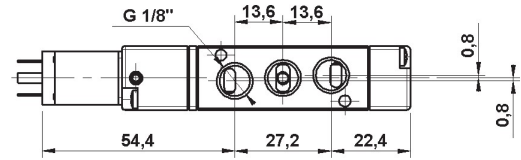

VALVES

CODE	REFERENCES
1151125101	EVR 1/8 18 5 SL PM OO M 12DC
1151125201	EVR 1/8 18 5 SL PM OO M 24DC
1151125601	EVR 1/8 18 5 SL PM OO M 24AC
1151125701	EVR 1/8 18 5 SL PM OO M 110AC
1151125801	EVR 1/8 18 5 SL PM OO M 220AC

TECHNICAL DATA

Connection size G1/8"
Working pressure 1÷10 Bar (0,10÷1,00 MPa)
Voltage 12V DC, 24V DC, 24V AC, 110V AC, 220V AC
Weight 0,087 kg

CYLINDERS

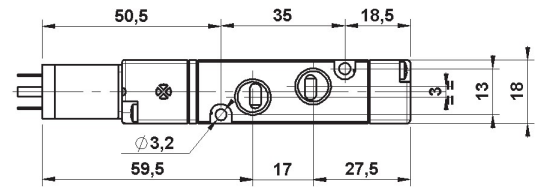
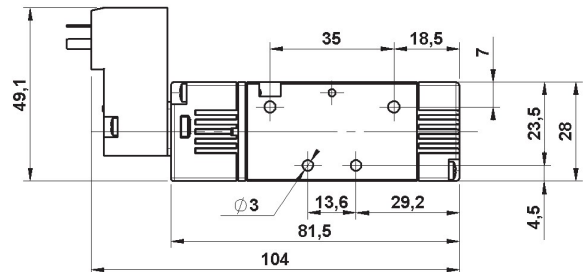

FITTINGS

5/2 - 5/3 DUOBLE SOLENOID VALVES



CODE	REFERENCES
1151125102	EVR 1/8 18 5 SL BS OO M 12DC
1151125202	EVR 1/8 18 5 SL BS OO M 24DC
1151125602	EVR 1/8 18 5 SL BS OO M 24AC
1151125702	EVR 1/8 18 5 SL BS OO M 110AC
1151125802	EVR 1/8 18 5 SL BS OO M 220AC

CODE	REFERENCES
1151126101	EVR 1/8 18 6 SL RC CC M 12DC
1151126201	EVR 1/8 18 6 SL RC CC M 24DC
1151126601	EVR 1/8 18 6 SL RC CC M 24AC
1151126701	EVR 1/8 18 6 SL RC CC M 110AC
1151126801	EVR 1/8 18 6 SL RC CC M 220AC

CODE	REFERENCES
1151126102	EVR 1/8 18 6 SL RC CA M 12DC
1151126202	EVR 1/8 18 6 SL RC CA M 24DC
1151126602	EVR 1/8 18 6 SL RC CA M 24AC
1151126702	EVR 1/8 18 6 SL RC CA M 110AC
1151126802	EVR 1/8 18 6 SL RC CA M 220AC

CODE	REFERENCES
1151126103	EVR 1/8 18 6 SL RC CP M 12DC
1151126203	EVR 1/8 18 6 SL RC CP M 24DC
1151126603	EVR 1/8 18 6 SL RC CP M 24AC
1151126703	EVR 1/8 18 6 SL RC CP M 110AC
1151126803	EVR 1/8 18 6 SL RC CP M 220AC

TECHNICAL DATA

Connection size G1/8"
Working pressure 5/2= 0,50÷10 Bar (0,050÷1,00 MPa) 5/3= 1,70÷10 Bar (0,17÷1,00 MPa)
Voltage 12V DC, 24V DC, 24V AC, 110V AC, 220V AC
Weight 0,102 kg

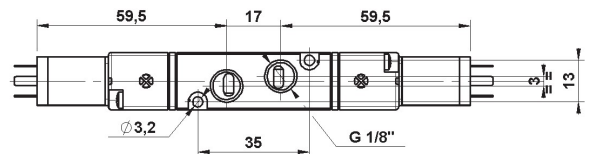
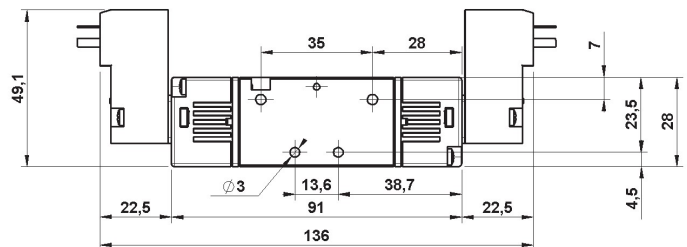
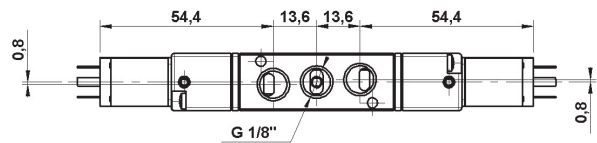

WATER PREPARATION

LINE 115 VPR 1/8" | PNEUMATIC VALVES

AIR PREPARATION

5/2 SINGLE PNEUMATIC VALVES



VALVES

CODE	REFERENCES
1151225001	VPR 1/8 18 5 PN PM OO M

TECHNICAL DATA

Connection size G1/8"
Working pressure 1±10 Bar (0,10±1,00 MPa)
Pilot operating pressure 1±10 (0,10±1,00 MPa)
Weight 0,072 kg

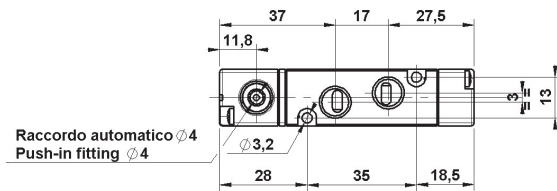
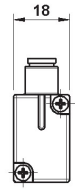
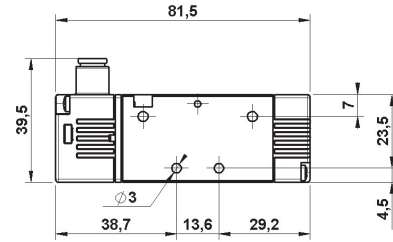
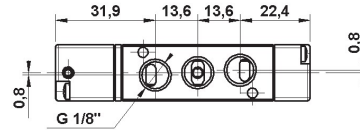

CYLINDERS

FITTINGS

PNEUMATICALLY OPERATED VALVES 5/3 - 5/3 BISTABLE

WATER PREPARATION



CODE	REFERENCES
1151225002	VPR 1/8 18 5 PN BS OO M
1151226001	VPR 1/8 18 6 PN RC CC M
1151226002	VPR 1/8 18 6 PN RC CA M
1151226003	VPR 1/8 18 6 PN RC CP M

TECHNICAL DATA

Connection size G1/8"
Working pressure 0±10 Bar (0±1,00 MPa)
Pilot operating pressure 5/2= 0,50±10 Bar (0,050±1,00 MPa) 5/3= 1,70±10 Bar (0,17±1,00 Mpa)
Weight 0,084 kg

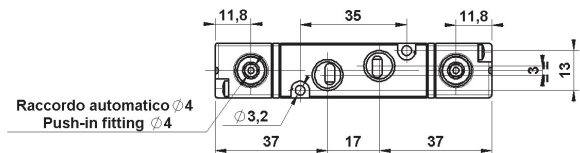
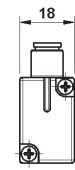
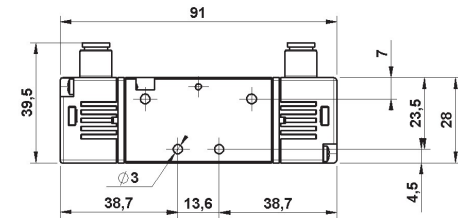
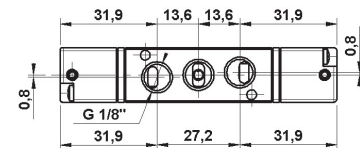

LINE 115 1/8" | 1/8" VALVES MANIFOLD



DIMENSIONS

N° OF STATION	A	B
2	67	47
3	86	66
4	105	85
5	124	104
6	143	123
7	162	142
8	181	161
9	200	180
10	219	190

MANIFOLD



CODE	REF.	LINE
1115C00002	2 POS - MANIFOLD	115 1/8"
1115C00003	3 POS - MANIFOLD	115 1/8"
1115C00004	4 POS - MANIFOLD	115 1/8"
1115C00005	5 POS - MANIFOLD	115 1/8"
1115C00006	6 POS - MANIFOLD	115 1/8"
1115C00007	7 POS - MANIFOLD	115 1/8"
1115C00008	8 POS - MANIFOLD	115 1/8"
1115C00009	9 POS - MANIFOLD	115 1/8"
1115C00010	10 POS - MANIFOLD	115 1/8"

BLANKING PLATE KIT



CODE	REF.	LINE
1315A00013	BLANKING PLATE KIT	115 1/8"

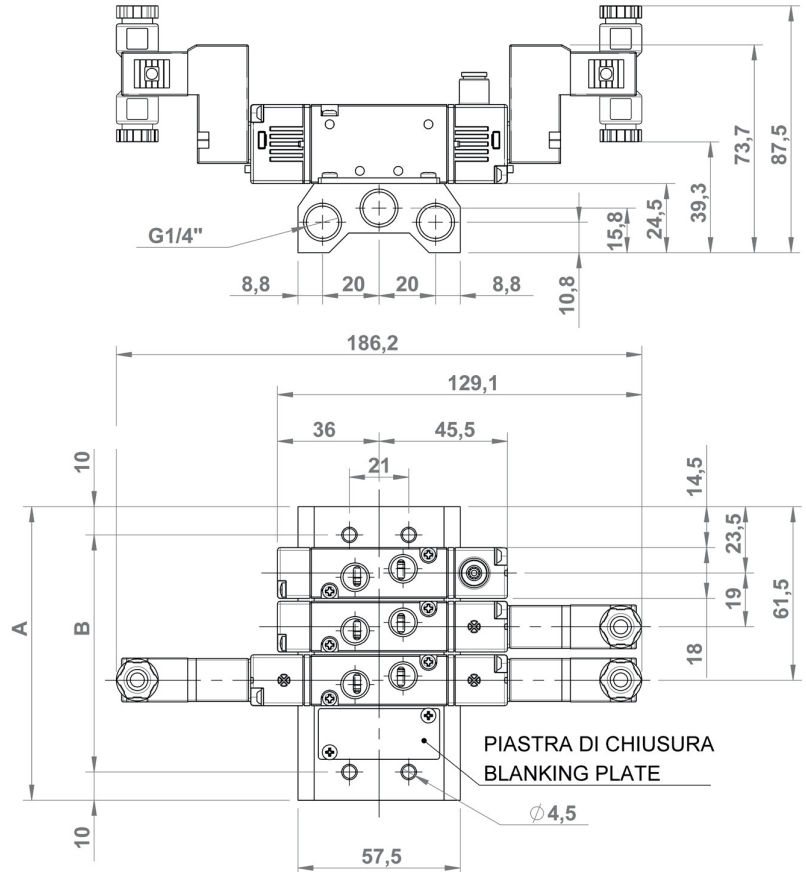

SPARE PARTS

MANIFOLD SEAL



CODE	REF.	CONF.
1315A00015	MANIFOLD SEAL	20 pieces

MANIFOLD SCREWS



CODE	REF.	CONF.
1115A00012	SCREW M3X30	2 pieces

AIR PREPARATION

VALVES

CYLINDERS

FITTINGS

WATER PREPARATION

LINE 115 1/8" | ACCESSORIES

AIR PREPARATION

15MM STANDARD CONNECTORS

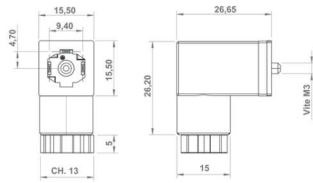

CODE	REF.	LINE
A502600014	15MM STANDARD CONNECTORS	115

VALVES

15MM LED CONNECTORS

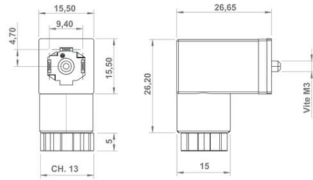

CODE	REF.	LINE
A502600020	LED CONNECTORS 15mm 24V	115
A502600021	LED CONNECTORS 15mm 115V	115
A502600022	LED CONNECTORS 15mm 230V	115

CYLINDERS

15MM CABLED LED CONNECTORS

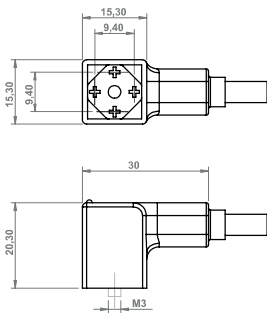

CODE	REF.	LINE
A502600023	15mm CABLED CONNECTOR 24V with LED CABLE L.3m	115
A502600024	15mm CABLED CONNECTOR 115V with LED CABLE L. 3m	115
A502600025	15mm CABLED CONNECTOR 230V with LED CABLE L. 3m	115

FITTINGS

SPARE PARTS

SOLENOID KIT FOR VALVE LINE 115



CODE	REF.	LINE
1110C00001	Solenoid kit 12V DC	115
1110C00002	Solenoid kit 24V DC	115
1110C00003	Solenoid kit 24V AC	115
1110C00004	Solenoid kit 110V AC	115
1110C00005	Solenoid kit 220V AC	115

WATER PREPARATION

SOLENOID PILOT SEAL



CODE	REF.	CONF.
A502600038	SOLENOID PILOT SEAL 115	10 pieces

LINE 120 1/8" | SOLENOID AND PNEUMATIC VALVES



GENERAL FEATURES

Construction	spool valve
Body size	22mm
Body material	technopolymer
Single use	YES
Manifold use	NO
Available functions	3/2; 5/2; 5/3

GENERAL TECHNICAL DATA

Fluid	filtered air with or without lubrication
Connections	1/8"
Temperature Range	-5 / +50°C (23 / 122°F) Please note: Below 3°C the air of the circuit must be free from humidity
Reference Flow Rate	P1= 6 bar; Δ P= 1 bar; 5/2= 670 (l/min), 5/3= 550 (l/min), 3/2= 690 l/min

GUIDE TO REFERENCES

EV 1/8" 22 3 SL PM NC P

Product EV = Solenoid valves VP = Pneumatic valves	Material P = Technopolymer
Connection 1/8" = G1/8"	Option NC = Normally closed NO = Normally opened CC = Closed centres CA = Opened centres CP = Pressure centres OO = 5/2
Size 22 = 22 mm	Return PM = Pneum. mech. spring BS = Bistable DF = Differential ML = Spring
Function 3 = 3/2 5 = 5/2 6 = 5/3	Operation PN = Pneumatic SL = Solenoid SA = Assisted solenoid with M5

HOW ORDERING A SOLENOID VALVE WITH COIL:

Step 1. Choose the valve without coil
 Example of a valve without coil: art. 1202125001 ref. EVR 1/4" 22 5 SL PM OO P

Step 2. Replace the 8th digit with the number corresponding to the required voltage

1 2 0 2 1 2 5 0 1

0	= Valve without coil
1	= 12V DC
2	= 24V DC
6	= 24V AC
7	= 110V AC
8	= 220V AC

Example of valve with coil: art. 1202125201 ref. EVR 1/4" 225 SL PM OO P 24VDC

USED MATERIALS

- | | |
|---|---|
| 1. Operator - Brass, Stainless steel | 7. Piston - POM |
| 2. Operator body - POM | 8. Gasket - NBR |
| 3. Piston gasket - NBR | 9. Spool - Nickel Plated Aluminium |
| 4. Insert - Brass | 10. Body valve - PBT+FV |
| 5. Spacers - Brass | 11. Base command - PA+FV |
| 6. Spring - Stainless steel | |

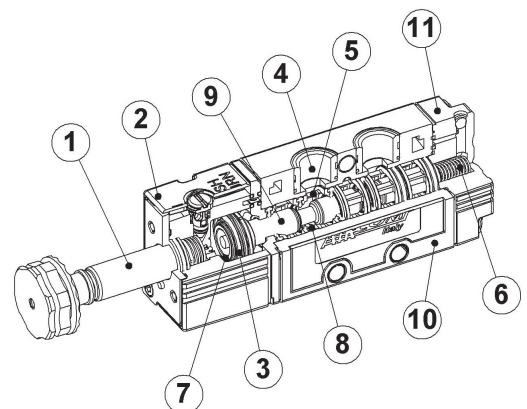

LINE 120 EV 1/8" | SOLENOID VALVES

AIR PREPARATION

VALVES

3/2 SINGLE SOLENOID VALVES



	CODE	REFERENCES
	1202123001	EV 1/8" 22 3 SL PM NC P
	1202123002	EV 1/8" 22 3 SL PM NO P

TECHNICAL DATA

Working pressure 1÷10 Bar (0,10÷1,00 MPa)

Voltage 12V DC, 24V AC, 110V AC, 220V AC

Manual override mono bistabile

Weight 0,080 kg

Coil is supplied separately page 2.60

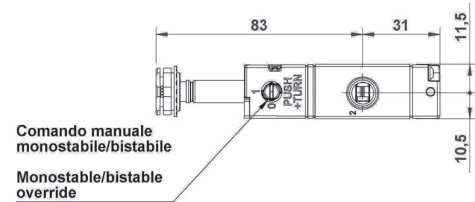
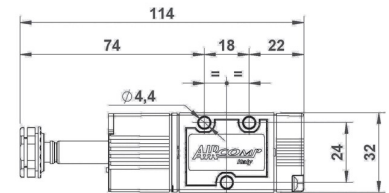
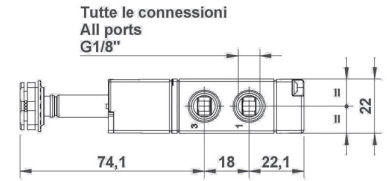

CYLINDERS

FITTINGS

3/2 DOUBLE SOLENOID VALVES



	CODE	REFERENCES
	1202123003	EV 1/8" 22 3 SL BS OO P

TECHNICAL DATA

Working pressure 1÷10 Bar (0,10÷1,00 MPa)

Voltage 12V DC, 24V AC, 110V AC, 220V AC

Manual override mono bistabile

Weight 0,102 kg

Coil is supplied separately page 2.60

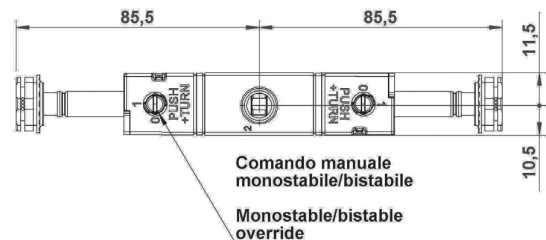
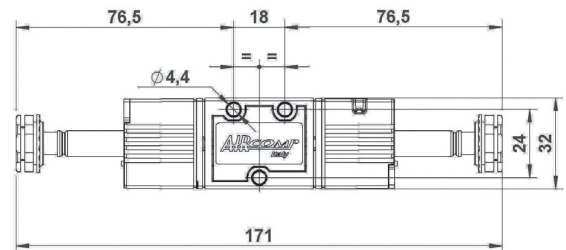
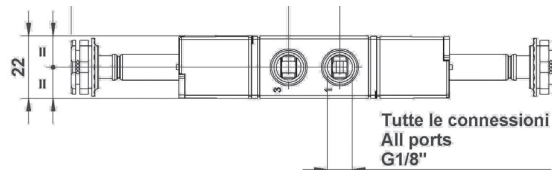

WATER PREPARATION

LINE 120 EV 1/8" | SOLENOID VALVES

5/2 SINGLE SOLENOID VALVES



CODE	REFERENCES
 1202125001	EV 1/8" 22 5 SL PM OO P

TECHNICAL DATA

Working pressure 1±10 Bar (0,10±1,00 MPa)

Voltage 12V DC, 24V AC, 110V AC, 220V AC

Manual override mono - bistabile

Weight 0,086 kg

Coil is supplied separately page 2.60

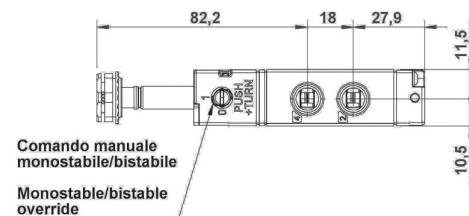
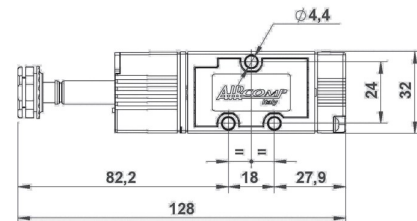
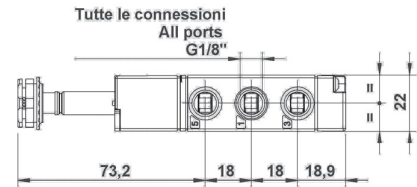

5/2 - 5/3 DOUBLE SOLENOID VALVES



CODE	REFERENCES
 1202125002	EV 1/8" 22 5 SL BS OO P
 1202126001	EV 1/8" 22 6 SL RC CC P
 1202126002	EV 1/8" 22 6 SL RC CA P
 1202126003	EV 1/8" 22 6 SL RC CP P

TECHNICAL DATA

Working pressure (5/2 - 5/3) 5/2= 0,50±10 bar (0,050±1 MPa)
5/3= 2±10 bar (0,20±1 MPa)

Voltage 12V DC, 24V AC, 110V AC, 220V AC

Manual override Mono - bistabile

Weight 0,116 kg

Coil is supplied separately page 2.60

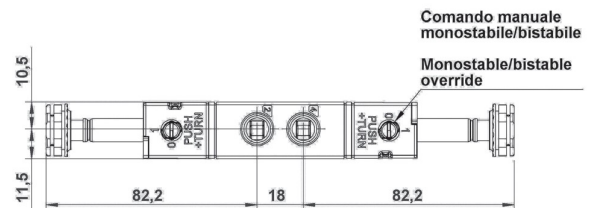
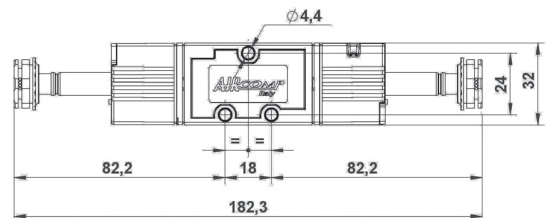
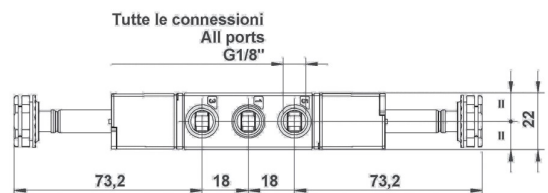

AIR PREPARATION

VALVES

CYLINDERS

FITTINGS

WATER PREPARATION

LINE 120 EV 1/8" | SOLENOID VALVES

AIR PREPARATION

VALVES

PILOT ASSISTED 3/2 SINGLE SOLENOID VALVES



	CODE	REFERENCES
	1202123004	EV 1/8" 22 3 SA ML NC P
	1202123005	EV 1/8" 22 3 SA ML NO P

TECHNICAL DATA

Working pressure 0÷10 Bar (0÷1,00 MPa)

Pressure separate air supply 1÷10 Bar (0,10÷1,00 MPa)

Voltage 12V DC, 24V AC, 110V AC, 220V AC

Manual override monostable

Weight 0,081 kg

Coil is supplied separately page 2.60

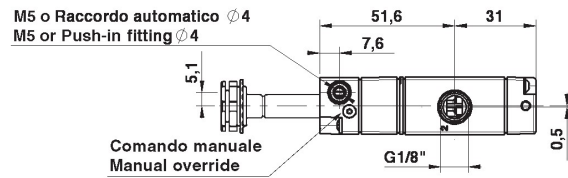
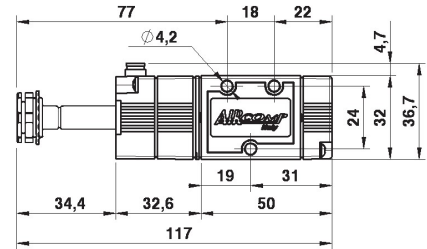
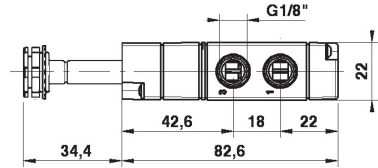

CYLINDERS

FITTINGS

PILOT ASSISTED 3/2 DOUBLE SOLENOID VALVES



	CODE	REFERENCES
	1202123006	EV 1/8" 22 3 SA BS OO P

TECHNICAL DATA

Working pressure 0÷10 Bar (0÷1,00 MPa)

Pressure separate air supply 0,5÷10 Bar (0,05÷1,00 MPa)

Voltage 12V DC, 24V AC, 110V AC, 220V AC

Manual override monostable

Weight 0,105 kg

Coil is supplied separately page 2.60

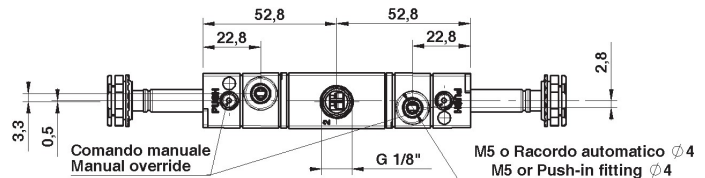
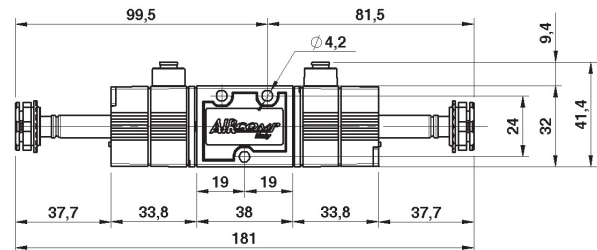
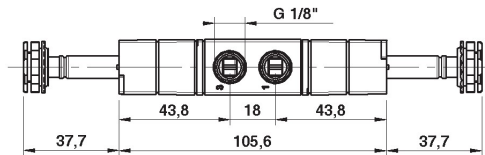

WATER PREPARATION

LINE 120 EV 1/8" | SOLENOID VALVES

PILOT ASSISTED 5/2 SINGLE SOLENOID VALVES



CODE	REFERENCES
 1202125003	EV 1/8" 22 5 SA ML 00 P

TECHNICAL DATA

Working pressure 0÷10 Bar (0÷1,00 MPa)

Pressure separate air supply 1÷10 Bar (0,10÷1,00 MPa)

Voltage 12V DC, 24V AC, 110V AC, 220V AC

Manual override monostable

Weight 0,087 kg

Coil is supplied separately page 2.60

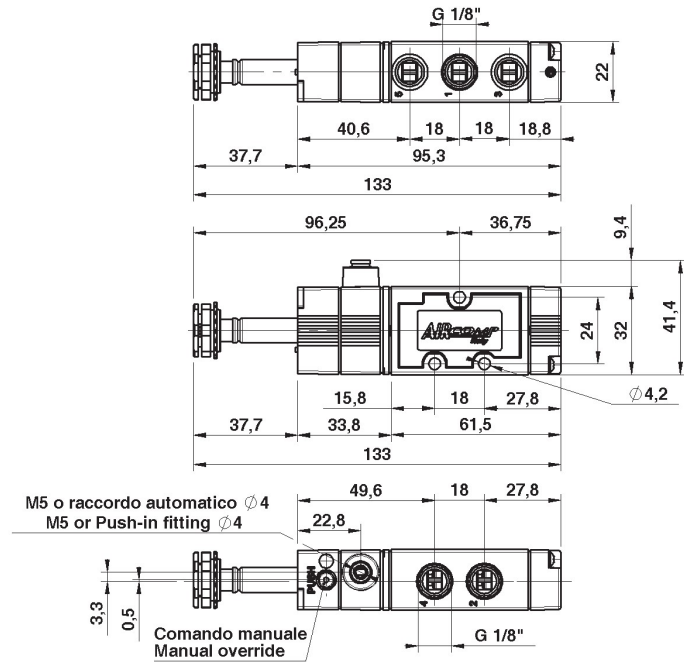

PILOT ASSISTED 5/2 - 5/3 DOUBLE SOLENOID VALVES

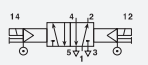
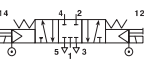
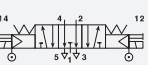
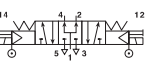

CODE	REFERENCES
 1202125004	EV 1/8" 22 5 SA BS 00 P
 1202126004	EV 1/8" 22 6 SA RC CC P
 1202126005	EV 1/8" 22 6 SA RC CA P
 1202126006	EV 1/8" 22 6 SA RC CP P

TECHNICAL DATA

Working pressure 0÷10 Bar (0÷1,00 MPa)

Pressure separate air supply

5/2= 0,5 ÷10 Bar (0,05÷1,00 MPa)

5/3= 2÷10 bar (0,20÷1 MPa)

Voltage 12V DC, 24V AC, 110V AC, 220V AC

Manual override monostable

Weight 0,118 kg

Coil is supplied separately page 2.60

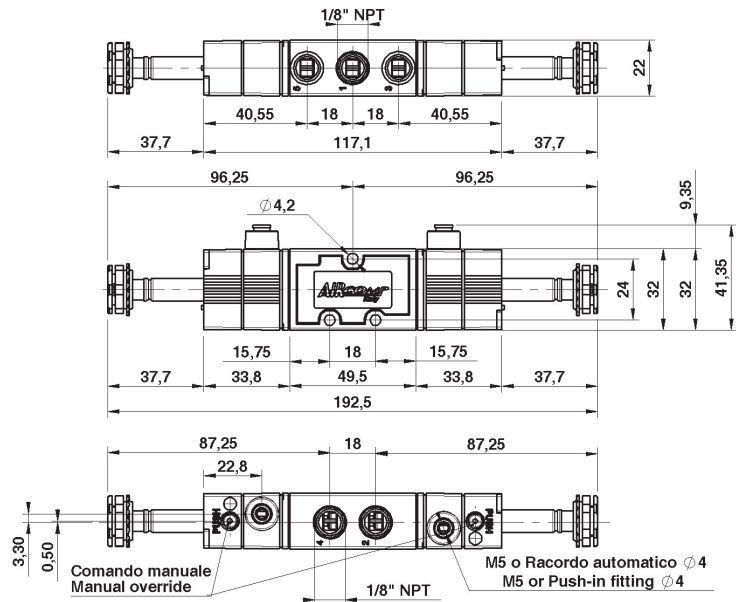

AIR PREPARATION

VALVES

CYLINDERS

FITTINGS

WATER PREPARATION

LINE 120 VP 1/8" | PNEUMATIC VALVES

AIR PREPARATION

3/2 SINGLE PNEUMATIC VALVES



	CODE	REFERENCES
	1202223001	VP 1/8" 22 3 PN PM NC P
	1202223002	VP 1/8" 22 3 PN PM NO P

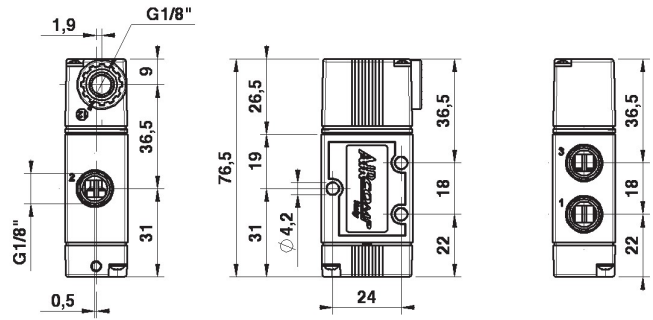

VALVES

TECHNICAL DATA

Working pressure 1÷10 Bar (0,10÷1,00 MPa)

Pilot operating pressure 1÷10 (0,10÷1,00 MPa)

Weight 0,070 kg

CYLINDERS

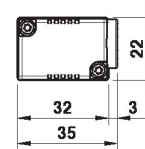

FITTINGS

3/2 DOUBLE PNEUMATIC VALVES



	CODE	REFERENCES
	1202223003	VP 1/8" 22 3 PN BS OO P
	1202223004	VP 1/8" 22 3 PN DF OO P

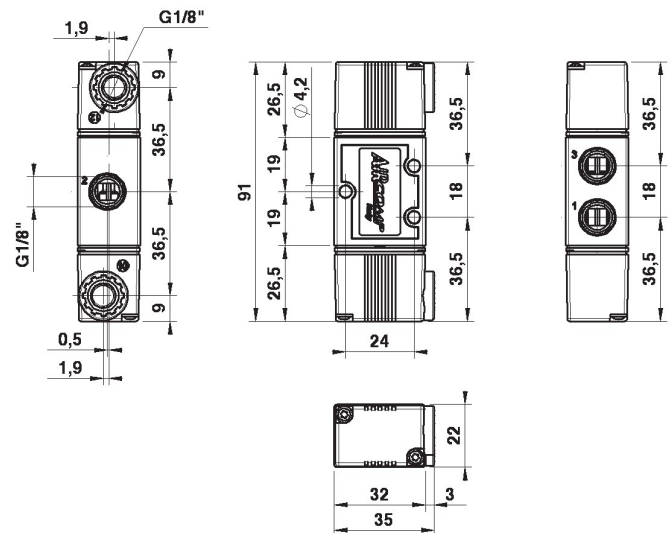

WATER PREPARATION

TECHNICAL DATA

Working pressure 0÷10 Bar (0÷1,00 MPa)

Pilot operating pressure 0,5÷10 (0,05÷1,00 MPa)

Weight 0,095 kg

LINE 120 VP 1/8" | PNEUMATIC VALVES

5/2 SINGLE PNEUMATIC VALVES



CODE	REFERENCES
1202225001	VP 1/8" 22 5 PN PM OO P

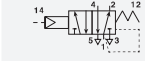

TECHNICAL DATA

Working pressure 1±10 Bar (0,10±1,00 MPa)

Pilot operating pressure 1±10 (0,10±1,00 MPa)

Weight 0,077 kg

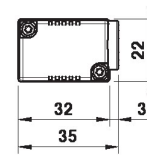
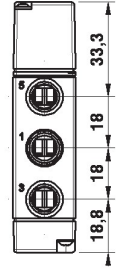
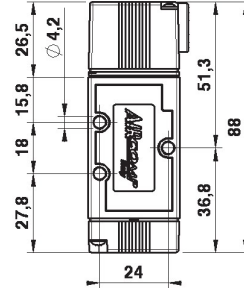
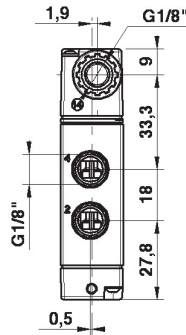

AIR PREPARATION

VALVES

CYLINDERS

FITTINGS

WATER PREPARATION

5/2 - 5/3 DOUBLE PNEUMATIC VALVES



CODE	REFERENCES
1202225002	VP 1/8" 22 5 PN BS OO P
1202225003	VP 1/8" 22 5 PN DF OO P
1202226001	VP 1/8" 22 6 PN RC CC P
1202226002	VP 1/8" 22 6 PN RC CA P
1202226003	VP 1/8" 22 6 PN RC CP P

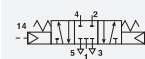
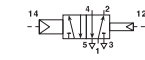
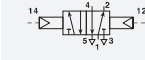

TECHNICAL DATA

Working pressure 0±10 Bar (0±1,00 MPa)

Pilot operating pressure 5/2= 0,5±10 (0,05±1,00 MPa)

5/3= 2±10 bar (0,20±1 MPa)

Weight 0,101 kg

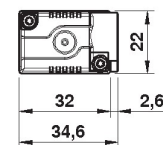
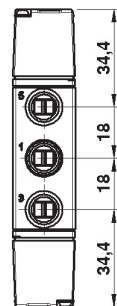
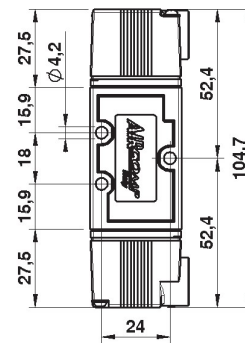
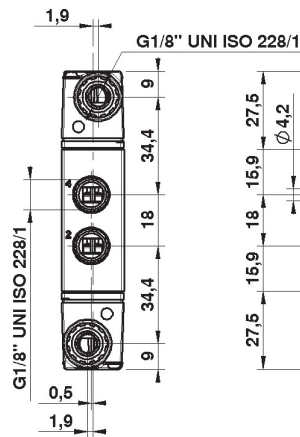

LINE 125 1/8"-1/4" | SOLENOID AND PNEUMATIC VALVES

AIR PREPARATION

VALVES

CYLINDERS

FITTINGS

WATER PREPARATION



GENERAL FEATURES

Construction	spool valve
Body size	22mm
Body material	technopolymer
Single use	YES
Manifold use	YES
Available functions	3/2; 5/2; 5/3

GENERAL TECHNICAL DATA

Fluid	filtered air with or without lubrication
Connections	1/8" - 1/4"
Temperature Range	-5 / +50°C (23 / 122°F) Please note: Below 3°C the air of the circuit must be free from humidity
Reference Flow Rate	P1= 6 bar; Δ P= 1 bar; 5/2= 800 l/min 5/3= 750 l/min 3/2=800 l/min

GUIDE TO REFERENCES

EVR 1/4" 22 5 SL PM 00 P

Product EVR = Solenoid valves VPR = Pneumatic valves	Material P = Technopolymer
Connection 1/8" = G1/8" 1/4" = G1/4"	Option NC = Normally closed NO = Normally opened CC = Closed centres CA = Opened centres CP = Pressure centres OO = 5/2
Size 22 = 22 mm	Return PM = Pneum. mech. spring BS = Bistable RC = Return to centre DF = Differential ML = Spring
Function 3 = 3/2 5 = 5/2 6 = 5/3	Operation PN = Pneumatic SL = Solenoid SA = Assisted solenoid with M5

HOW ORDERING A SOLENOID VALVE WITH COIL:

Step 1. Choose the valve without coil
 Example of a valve without coil: cod. 1252135001 ref. EVR 1/4" 22 5 SL PM 00 P

Step 2. Replace the 8th digit with the number corresponding to the required voltage

1 2 5 2 1 3 5 0 1

0	= Valve without coil
1	= 12V DC
2	= 24V DC
6	= 24V AC
7	= 110V AC
8	= 220V AC

Example of valve with coil: cod. 1252135201 ref. EVR 1/4" 22 5 SL PM 00 P 24VDC

USED MATERIALS

- | | |
|--|--|
| 1. Operator -Brass, Stainless steel | 7. Piston gasket -NBR |
| 2. Operator body -POM | 8. Spool -Nickel Plated Aluminium |
| 3. Body valve -PBT+FV | 9. Seals - NBR |
| 4. Insert -Brass | 10. Spacers -Brass |
| 5. Base command -PA+FV | 11. Spring -Stainless steel |
| 6. Piston -POM | |

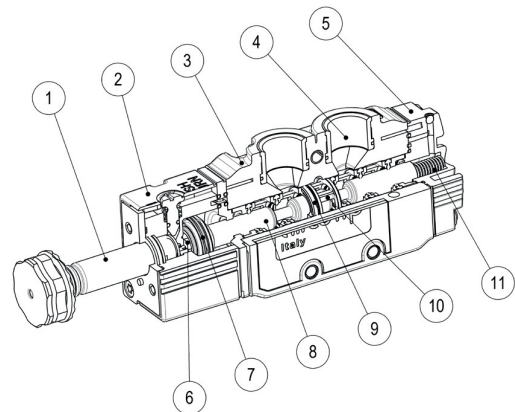

LINE 125 1/8"-1/4" | SOLENOID VALVES

3/2 SINGLE SOLENOID VALVES



	CODE	REFERENCES
	1252123001	EVR 1/8" 22 3 SL PM NC P
	1252133001	EVR 1/4" 22 3 SL PM NC P
	1252123002	EVR 1/8" 22 3 SL PM NO P
	1252133002	EVR 1/4" 22 3 SL PM NO P

TECHNICAL DATA

Working pressure 1±10 bar (0,10±1,00 Mpa)

Voltage 12V DC, 24V DC, 24V AC, 110V AC, 220V AC

Manual override Mono-bistabile

Weight 0,104 kg

Coil is supplied separately page 2.60

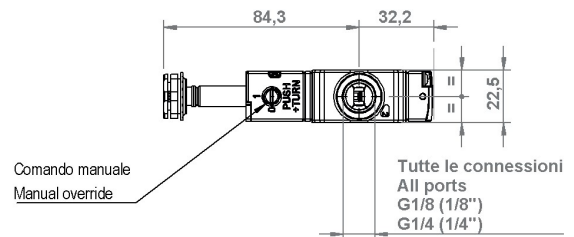
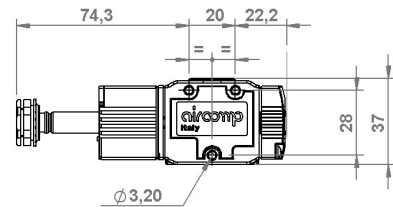
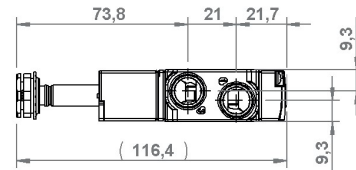

3/2 DOUBLE SOLENOID VALVES



	CODE	REFERENCES
	1252123003	EVR 1/8" 22 3 SL BS OO P
	1252133003	EVR 1/4" 22 3 SL BS OO P

TECHNICAL DATA

Working pressure 0,50±10 bar (0,05±1,00 Mpa)

Voltage 12V DC, 24V DC, 24V AC, 110V AC, 220V AC

Manual override Mono-bistabile

Weight 0,137 kg

Coil is supplied separately page 2.60

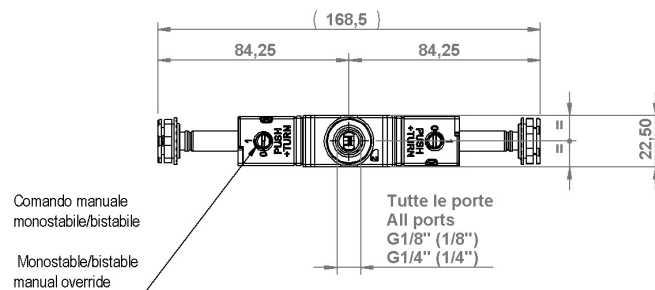
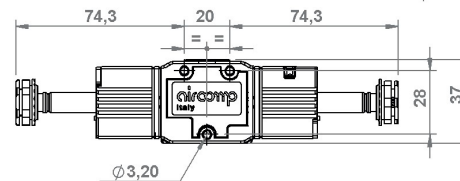
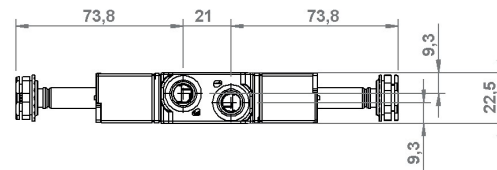

AIR PREPARATION

VALVES

CYLINDERS

FITTINGS

WATER PREPARATION

LINE 125 EVR 1/8"-1/4" | SOLENOID VALVES

AIR PREPARATION

VALVES

5/2 SINGLE SOLENOID VALVES



CODE	REFERENCES
1252125001	EVR 1/8" 22 5 SL PM OO P
1252135001	EVR 1/4" 22 5 SL PM OO P

TECHNICAL DATA

Working pressure 1±10 Bar (0,10±1,00 MPa)
Voltage 24DC, 24V AC, 110V, 220V AC
Manual override Mono - bistable
Weight 0,106 kg
Coil is supplied separately page 2.60

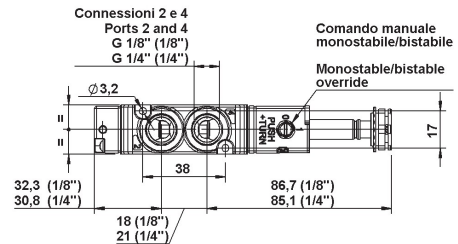
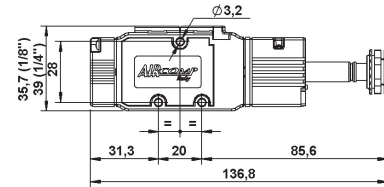
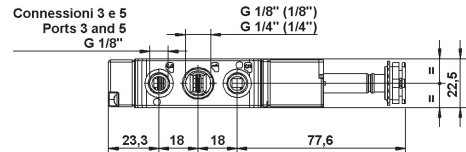

CYLINDERS

FITTINGS

PILOT ASSISTED 3/2 DOUBLE SOLENOID VALVES



CODE	REFERENCES
1252125002	EVR 1/8" 22 5 SL BS OO P
1252135002	EVR 1/4" 22 5 SL BS OO P

CODE	REFERENCES
1252126001	EVR 1/8" 22 6 SL RC CC P
1252136001	EVR 1/4" 22 6 SL RC CC P

CODE	REFERENCES
1252126002	EVR 1/8" 22 6 SL RC CA P
1252136002	EVR 1/4" 22 6 SL RC CA P

CODE	REFERENCES
1252126003	EVR 1/8" 22 6 SL RC CP P
1252136003	EVR 1/4" 22 6 SL RC CP P

TECHNICAL DATA

Working pressure 5/2=0,50±10 bar (0,050± 1 MPa) 5/3=2±10 bar (0,20±1 MPa)
Voltage 24DC, 24V AC, 110V, 220V AC
Manual override Mono - bistable
Weight 0,136 kg
Coil is supplied separately page 2.60

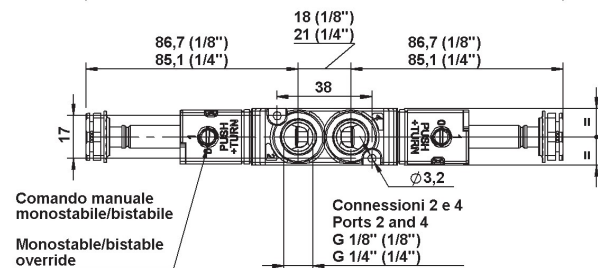
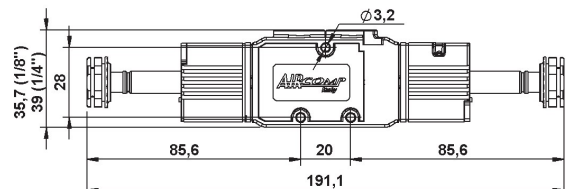
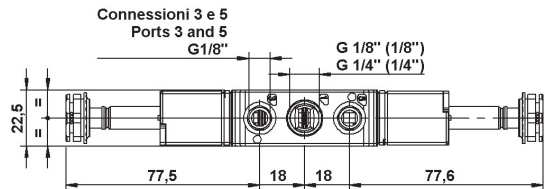

WATER PREPARATION

LINE 125 EVR 1/8"-1/4" | SOLENOID VALVES

PILOT ASSISTED, 3/2 SINGLE SOLENOID VALVES



	CODE	REFERENCES
	1252123004	EVR 1/8" 22 3 SA ML NC P
	1252133004	EVR 1/4" 22 3 SA ML NC P
	1252123005	EVR 1/8" 22 3 SA ML NO P
	1252133005	EVR 1/4" 22 3 SA ML NO P

TECHNICAL DATA

Working pressure 0÷10 bar (0÷1,00 Mpa)

Actuating pressure (separate air supply)
1÷10 bar (0,10÷1,00 Mpa)

Voltage 12V DC, 24V DC, 24V AC, 110V AC, 220V AC

Manual override Monostable

Weight 0,107 kg

Coil is supplied separately page 2.60

Tutte le connessioni
All connections

G1/8 (1/8")

G1/4 (1/4")

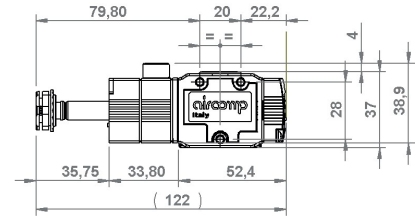
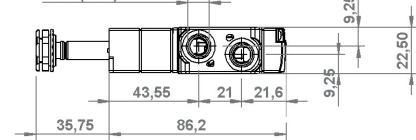

M5 o raccordo automatico Ø4

M5 or Push-in fitting Ø4

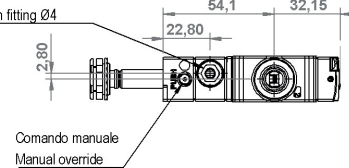

SOLENOID VALVES 3/2 BISTABLE PILOT ASSISTED



	CODE	REFERENCES
	1252123006	EVR 1/8" 22 3 SA BS OO P
	1252133006	EVR 1/4" 22 3 SA BS OO P

TECHNICAL DATA

Working pressure 0÷10 bar (0÷1,00 Mpa)

Actuating pressure (separate air supply)
0,50÷10 bar (0,05÷1,00 Mpa)

Voltage 12V DC, 24V DC, 24V AC, 110V AC, 220V AC

Manual override Monostable

Weight 0,148 kg

Coil is supplied separately page 2.60

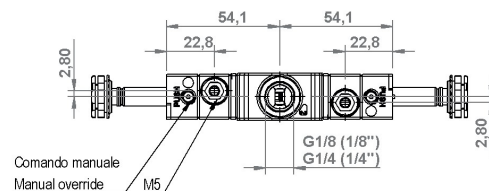
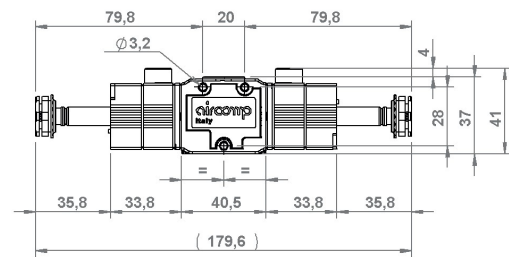
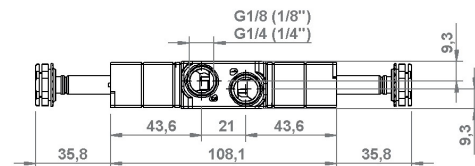

AIR PREPARATION

VALVES

CYLINDERS

FITTINGS

WATER PREPARATION

LINE 125 EVR 1/8"-1/4" | SOLENOID VALVES

AIR PREPARATION

PILOT ASSISTED, 5/2 SINGLE SOLENOID VALVES



VALVES

	CODE	REFERENCES
	1252125003	EVR 1/8" 22 5 SA ML OO P
	1252135003	EVR 1/4" 22 5 SA ML OO P

TECHNICAL DATA

Working pressure 0±10 Bar (0±1,00 MPa)

Actuating pressure (separate air supply)
1±10 Bar (0,10±1,00 MPa)

Voltage 24DC, 24V AC, 110V, 220V AC

Manual override Monostable

Weight 0,107 kg

Coil is supplied separately page 2.60

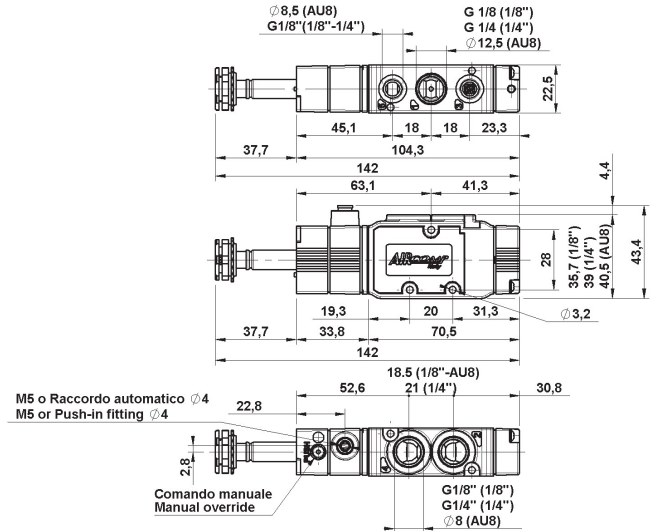

CYLINDERS

FITTINGS

PILOT ASSISTED, 5/2 - 5/3 DOUBLE SOLENOID VALVES



WATER PREPARATION

	CODE	REFERENCES
	1252125004	EVR 1/8" 22 5 SA BS OO P
	1252135004	EVR 1/4" 22 5 SA BS OO P
	1252126004	EVR 1/8" 22 6 SA RC CC P
	1252136004	EVR 1/4" 22 6 SA RC CC P
	1252126005	EVR 1/8" 22 6 SA RC CA P
	1252136005	EVR 1/4" 22 6 SA RC CA P
	1252126006	EVR 1/8" 22 6 SA RC CP P
	1252136006	EVR 1/4" 22 6 SA RC CP P

TECHNICAL DATA

Working pressure (5/2 - 5/3) 0±10 Bar (0±1,00 MPa)

Actuating pressure (separate air supply)
5/2= 0,5±10 Bar (0,05±1,00 MPa)

5/3= 2±10 bar (0,20±1 MPa)

Voltage 24DC, 24V AC, 110V, 220V AC

Manual override Monostable

Weight 0,136 kg

Coil is supplied separately page 2.60

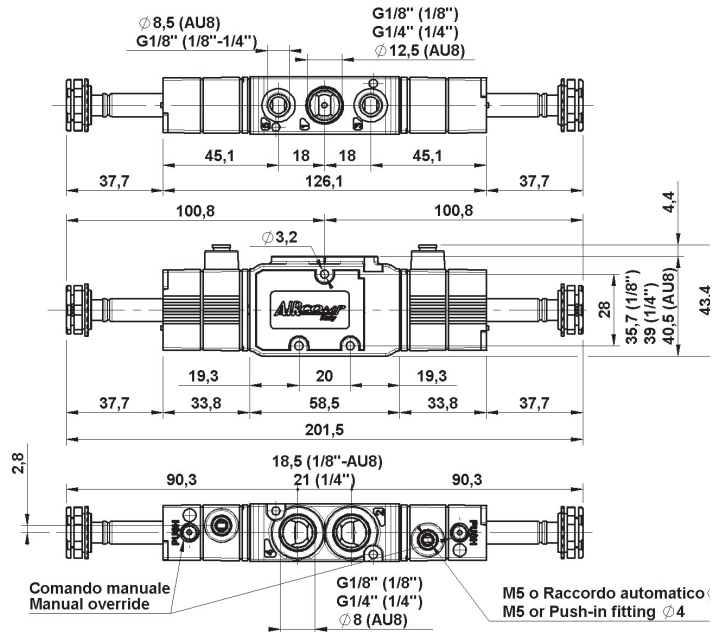

LINE 125 VPR 1/8"-1/4" | PNEUMATIC VALVES

3/2 SINGLE PNEUMATIC VALVES



	CODE	REFERENCES
	1252223001	VPR 1/8" 22 3 PN PM NC P
	1252233001	VPR 1/4" 22 3 PN PM NC P
	1252223002	VPR 1/8" 22 3 PN PM NO P
	1252233002	VPR 1/4" 22 3 PN PM NO P

TECHNICAL DATA

Working pressure 1±10 bar (0,10±1,00 Mpa)

Pilot operating pressure 1±10 bar (0,10±1,00 Mpa)

Weight 0,083 kg

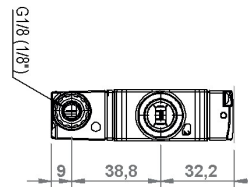
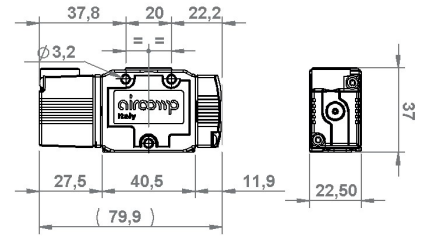
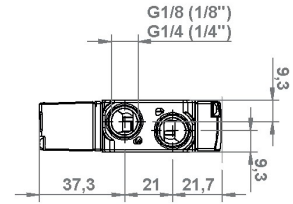

3/2 DOUBLE PNEUMATIC VALVES



	CODE	REFERENCES
	1252223003	VPR 1/8" 22 3 PN BS OO P
	1252233003	VPR 1/4" 22 3 PN BS OO P

TECHNICAL DATA

Working pressure 0±10 bar (0±1,00 Mpa)

Pilot operating pressure 0,50±10 bar (0,05±1,00 Mpa)

Weight 0,096 kg

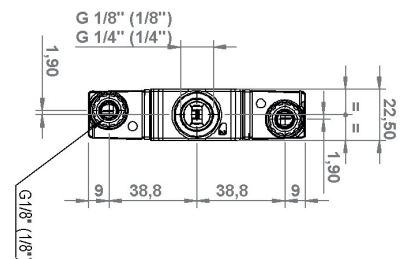
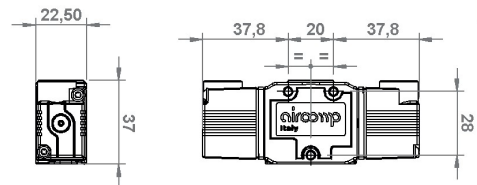
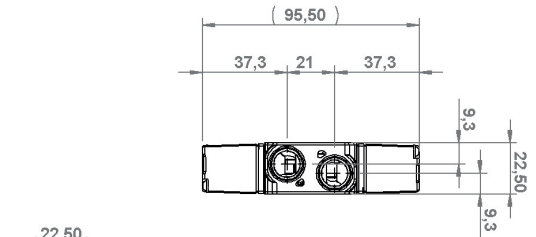

AIR PREPARATION

VALVES

CYLINDERS

FITTINGS

WATER PREPARATION

LINE 125 VPR 1/8"-1/4" | PNEUMATIC VALVES

AIR PREPARATION

5/2 SINGLE PNEUMATIC VALVES



	CODE	REFERENCES
	1252225001	VPR 1/8" 22 5 PN PM OO P
	1252235001	VPR 1/4" 22 5 PN PM OO P

TECHNICAL DATA

Working pressure 1÷10 Bar (0,10÷1,00 MPa)

Operating pressure 1÷10 Bar (0,10÷1,00 MPa)

Weight 0,097 kg

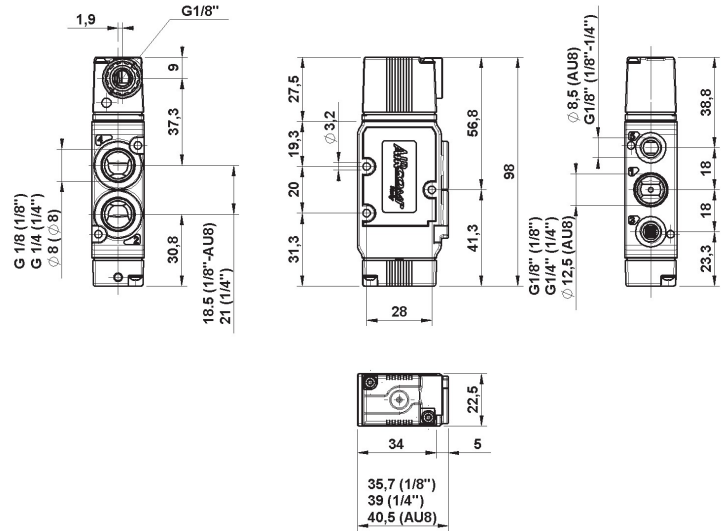

CYLINDERS

FITTINGS

5/2 - 5/3 DOUBLE PNEUMATIC VALVES



	CODE	REFERENCES
	1252225002	VPR 1/8" 22 5 PN BS OO P
	1252235002	VPR 1/4" 22 5 PN BS OO P
	1252225003	VPR 1/8" 22 5 PN DF OO P
	1252235003	VPR 1/4" 22 5 PN DF OO P
	1252226001	VPR 1/8" 22 6 PN RC CC P
	1252236001	VPR 1/4" 22 6 PN RC CC P
	1252226002	VPR 1/8" 22 6 PN RC CA P
	1252236002	VPR 1/4" 22 6 PN RC CA P
	1252226003	VPR 1/8" 22 6 PN RC CP P
	1252236003	VPR 1/4" 22 6 PN RC CP P

TECHNICAL DATA

Working pressure 0÷10 Bar (0÷1,00 MPa)

Operating pressure

5/2: 0,5÷10 Bar (0,05÷1,00 MPa)

5/3: 2÷10 bar (0,20÷1 MPa)

Weight 0,121 kg

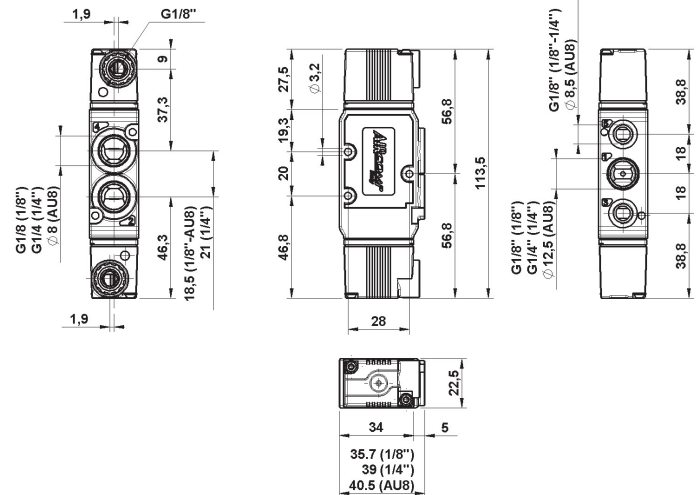

LINE 125 1/4"-1/8" | VALVES MANIFOLD

AIR PREPARATION

VALVES

CYLINDERS

FITTINGS

WATER PREPARATION

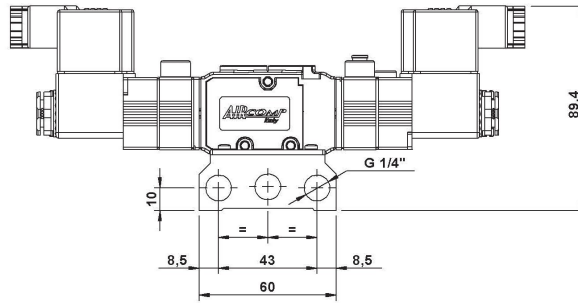

DIMENSIONS

N° OF STATIONS	A	B
2	69	57
3	92	80
4	115	103
5	138	126
6	161	149
7	184	172
8	207	195
9	230	218
10	253	241

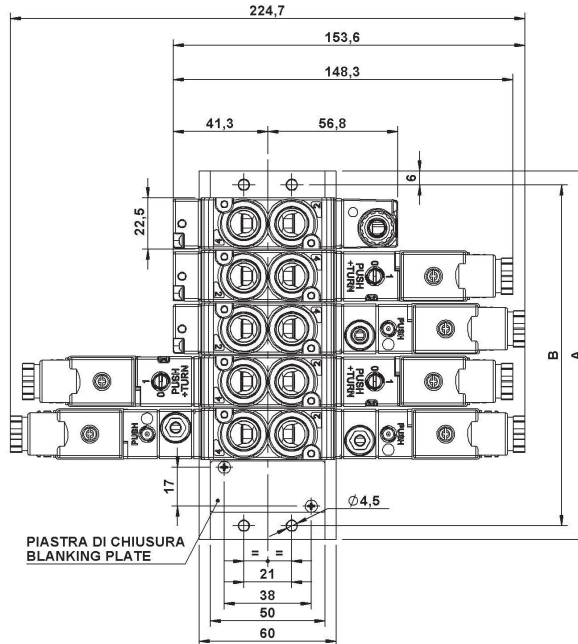

VALVOLA PNEUMATICA MONOSTABILE

VALVOLA ELETTRO-PNEUMATICA MONOSTABILE

VALVOLA ELETTRO-PNEUMATICA MONOSTABILE A.S.*

VALVOLA ELETTRO-PNEUMATICA BISTABILE

VALVOLA ELETTRO-PNEUMATICA BISTABILE A.S.*

*A.S.: ALIMENTAZIONE SEPARATA

MANIFOLD



CODE	REF.	LINE
1325A00002	MANIFOLD STB 1/4" 22 2 POS	125 -127 - 128
1325A00003	MANIFOLD STB 1/4" 22 3 POS	125 -127 - 128
1325A00004	MANIFOLD STB 1/4" 22 4 POS	125 -127 - 128
1325A00005	MANIFOLD STB 1/4" 22 5 POS	125 -127 - 128
1325A00006	MANIFOLD STB 1/4" 22 6 POS	125 -127 - 128
1325A00007	MANIFOLD STB 1/4" 22 7 POS	125 -127 - 128
1325A00008	MANIFOLD STB 1/4" 22 8 POS	125 -127 - 128
1325A00009	MANIFOLD STB 1/4" 22 9 POS	125 -127 - 128
1325A00010	MANIFOLD STB 1/4" 22 10 POS	125 -127 - 128

SEPARATE FEED KIT

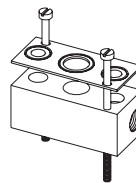

CODE	REF.	LINE
1325C00001	Separate feed KIT	125 -127

BLANKING PLATE KIT



CODE	REF.	LINEA
1325A00013	BLANKING PLATE KIT	125 -127 - 128

SPARE PARTS



CODE	REF.	CONF.
1325A00012	Manifold seal	20 pieces



CODE	REF.	CONF.
1325A00017	Manifold screw	20 pieces

LINE 127 1/8"-1/4" | SOLENOID AND PNEUMATIC VALVES

AIR PREPARATION

VALVES



CYLINDERS

FITTINGS

WATER PREPARATION

GENERAL FEATURES

Construction	spool valve
Body size	22mm
Body material	aluminium
Single use	YES
Manifold use	YES
Available functions	3/2; 5/2; 5/3

GENERAL TECHNICAL DATA

Construction	spool valve
Fluid	filtered air with or without lubrication
Connections	1/8" - 1/4"
Temperature Range	-5 / +50°C (23 / 122°F) Please note: Below 3°C the air of the circuit must be free from humidity
Reference Flow Rate	P1= 6 bar; Δ P= 1 bar; 5/2= 800 l/min, 5/3: 750 l/min, 3/2= 750 l/min

GUIDE TO REFERENCES

EVR 1/4" 22 3 SL PM NC M

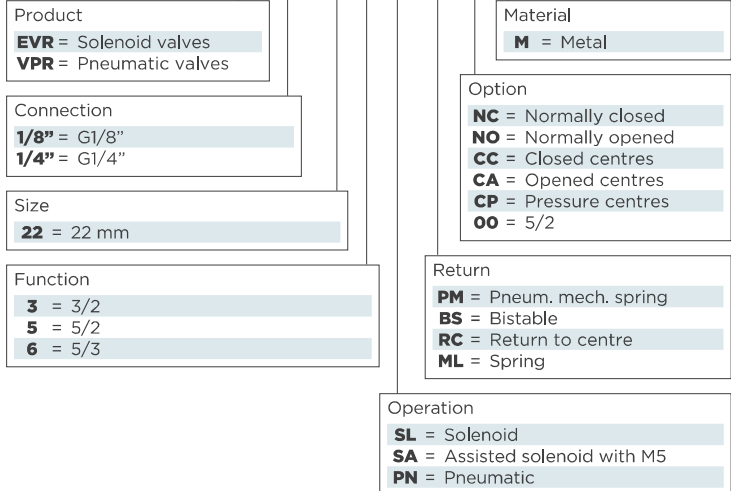

HOW ORDERING A SOLENOID VALVE WITH COIL:

Step 1. Choose the valve without coil

Example of a valve without coil: cod. 1272135001 ref. EVR 1/4" 22 3 SL PM NC M

Step 2. Replace the 8th digit with the number corresponding to the required voltage

1 2 5 2 1 3 5 0 1

0	= Valve without coil
1	= 12V DC
2	= 24V DC
6	= 24V AC
7	= 110V AC
8	= 220V AC

Example of valve with coil: cod. 1272135201 ref. EVR 1/4" 22 3 SL PM NC M 24VDC

USED MATERIALS

- | | |
|---|-------------------------------|
| 1. Operator - Brass, Stainless steel | 7. Piston gasket - NBR |
| 2. Operator body - POM | 8. Piston - POM |
| 3. Body valve - Aluminium | 9. Spool - Aluminium |
| 4. Base command - PA+FV | 10. Body valve - PBT |
| 5. Spacers - POM | 11. Spool gasket - NBR |
| 6. Spring - Stainless steel | |

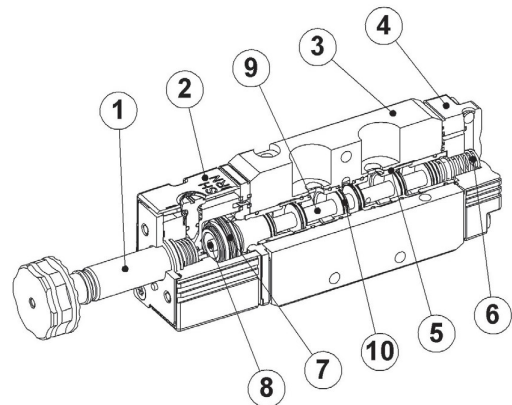

LINE 127 EVR 1/8"-1/4" | SOLENOID VALVES

3/2 SINGLE SOLENOID VALVES



	CODE	REFERENCES
	1272123001	EVR 1/8" 22 3 SL PM NC M
	1272133001	EVR 1/4 22 3 SL PM NC M
	1272123002	EVR 1/8" 22 3 SL PM NO M
	1272133002	EVR 1/4 22 3 SL PM NO M

TECHNICAL DATA

Working pressure 1±10 Bar (0,10±1,00 MPa)

Voltage 24DC, 24V AC, 110V, 220V AC

Manual override Mono-bistable

Weight 0,140 kg

Coil is supplied separately page 2.60

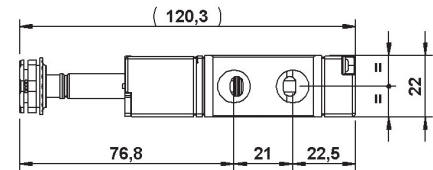
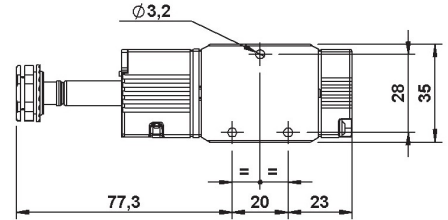
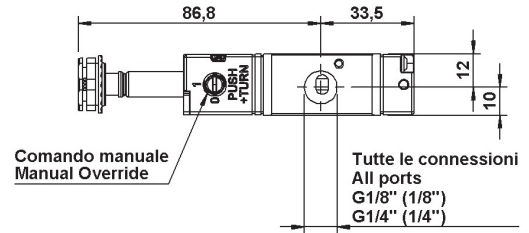

3/2 DOUBLE SOLENOID VALVES



	CODE	REFERENCES
	1272123003	EVR 1/8" 22 3 SL BS OO M
	1272133003	EVR 1/4 22 3 SL BS OO M

TECHNICAL DATA

Working pressure 0,5±10 Bar (0,05±1,00 MPa)

Voltage 24DC, 24V AC, 110V, 220V AC

Manual override Mono-bistable

Weight 0,162 kg

Coil is supplied separately page 2.60

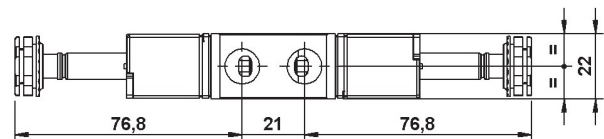
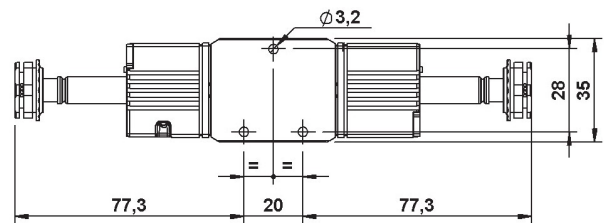
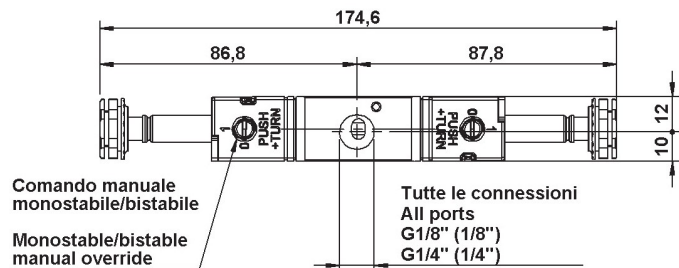

AIR PREPARATION

VALVES

CYLINDERS

FITTINGS

WATER PREPARATION

LINE 127 EVR 1/8"-1/4" | SOLENOID VALVES

AIR PREPARATION

5/2 SINGLE SOLENOID VALVES



	CODE	REFERENCES
	1272125001	EVR 1/8 22 5 SL PM OO M
	1272135001	EVR 1/4 22 5 SL PM OO M

TECHNICAL DATA

Working pressure 1±10 Bar (0,10±1,00 MPa)

Voltage 24DC, 24V AC, 110V, 220V AC

Manual override Mono-bistable

Weight 0,146 kg

Coil is supplied separately page 2.60

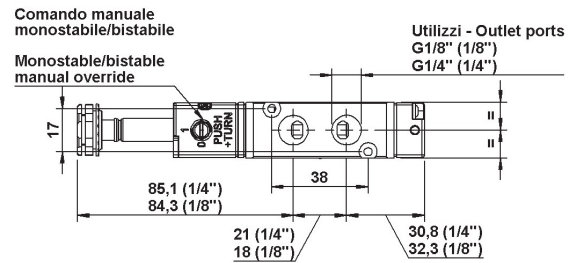
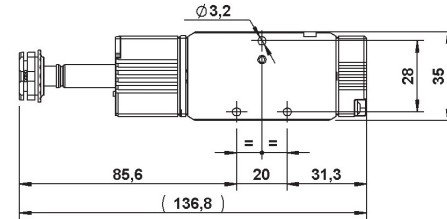
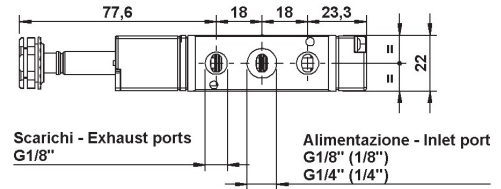

VALVES

CYLINDERS

FITTINGS

5/2 - 5/3 DUOBLE SOLENOID VALVES



	CODE	REFERENCES
	1272125002	EVR 1/8 22 5 SL BS OO M
	1272135002	EVR 1/4 22 5 SL BS OO M
	1272126001	EVR 1/8 22 6 SL RC CC M
	1272136001	EVR 1/4 22 6 SL RC CC M
	1272126002	EVR 1/8 22 6 SL RC CA M
	1272136002	EVR 1/4 22 6 SL RC CA M
	1272126003	EVR 1/8 22 6 SL RC CP M
	1272136003	EVR 1/4 22 6 SL RC CP M

TECHNICAL DATA

Working pressure 5/2= 0,50±10bar (0,050±1 MPa)
5/3= 2±10 bar (0,20±1 MPa)

Voltage 24DC, 24V AC, 110V, 220V AC

Manual override Mono-bistable

Weight 0,176 kg

Coil is supplied separately page 2.60

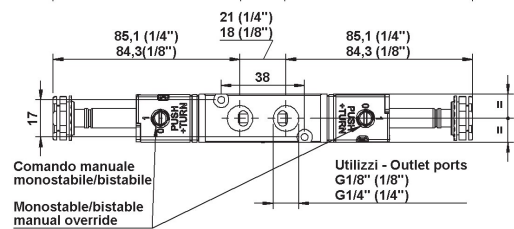
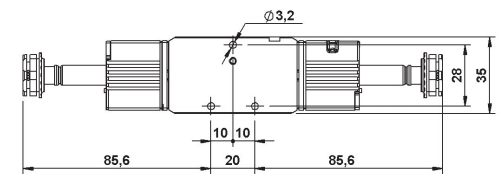
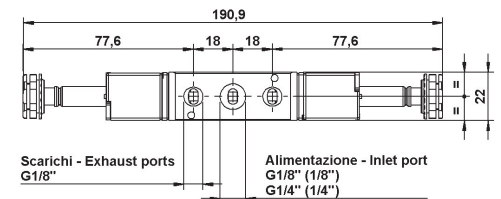

WATER PREPARATION

LINE 127 EVR 1/8"-1/4" | SOLENOID VALVES

PILOT ASSISTED, 3/2 SINGLE SOLENOID VALVES



	CODE	REFERENCES
	1272123004 1272133004	EVR 1/8" 22 3 SA ML NC M EVR 1/4 22 3 SA ML NC M
	1272123005 1272133005	EVR 1/8" 22 3 SA ML NO M EVR 1/4 22 3 SA ML NO M

TECHNICAL DATA

Working pressure 0÷10 Bar (0÷1,00 MPa)

Actuating pressure separate air supply
1÷10 Bar (0,10÷1,00 MPa)

Manual override Mono-bistable

Weight 0,141 kg

Coil is supplied separately page 2.60

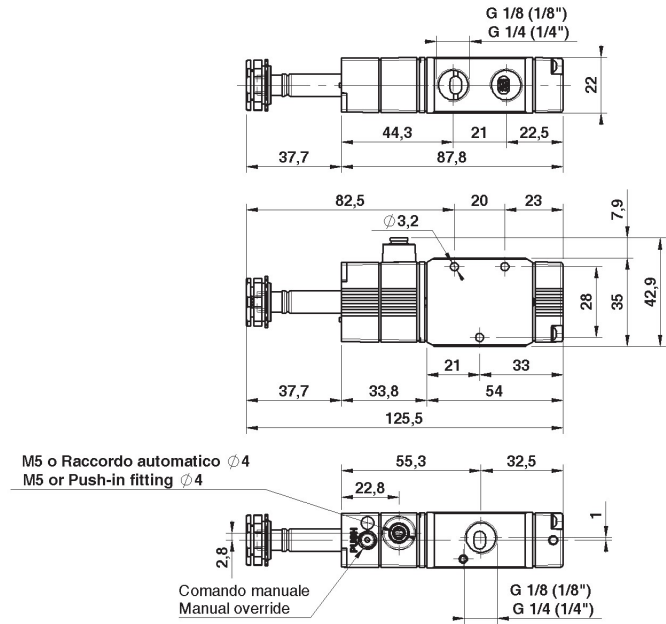

AIR PREPARATION

VALVES

CYLINDERS

FITTINGS

WATER PREPARATION

PILOT ASSISTED, 3/2 DOUBLE SOLENOID VALVES



	CODE	REFERENCES
pilot connections. M5		
	1272123006 1272133006	EVR 1/8" 22 3 SA BS OO M EVR 1/4 22 3 SA BS OO M

TECHNICAL DATA

Working pressure 0÷10 Bar (0÷1,00 MPa)

Actuating pressure separate air supply
0,5÷10 Bar (0,05÷1,00 MPa)

Manual override Mono-bistable

Weight 0,165 kg

Coil is supplied separately page 2.60

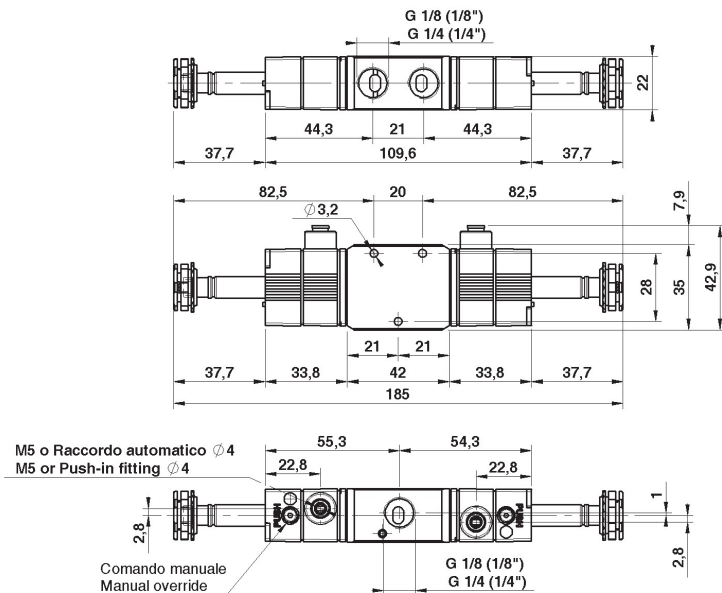

LINE 127 EVR 1/8"-1/4" | SOLENOID VALVES

AIR PREPARATION

PILOT ASSISTED, 5/2 SINGLE SOLENOID VALVES



CODE	REFERENCES
connessione pilot. M5	
 1272125003	EVR 1/8 22 5 SA ML OO M
1272135003	EVR 1/4 22 5 SA ML OO M

TECHNICAL DATA

Working pressure 0÷10 Bar (0÷1,00 MPa)

Actuating pressure separate air supply
1÷10 Bar (0,10÷1,00 MPa)

Manual override Mono-bistable

Weight 0,141 kg

Coil is supplied separately page 2.60

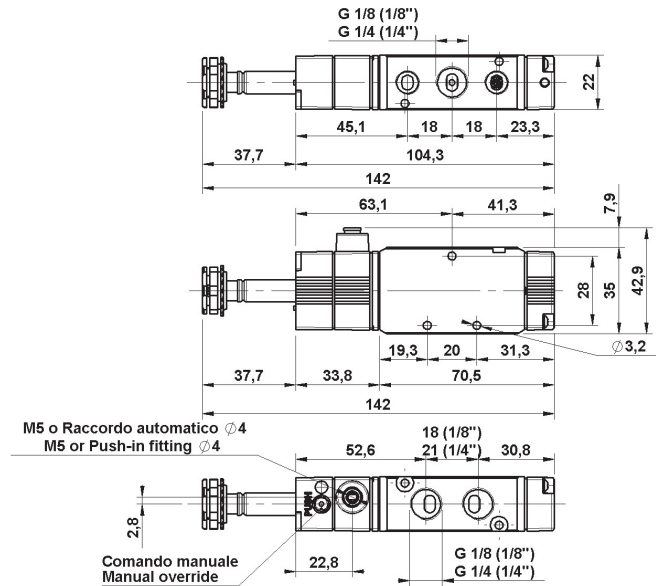



VALVES

CYLINDERS

FITTINGS

PILOT ASSISTED, 5/2 - 5/3 DOUBLE SOLENOID VALVES

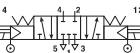

CODE	REFERENCES
 1272125004	
1272135004	EVR 1/8 22 5 SA BS OO M
1272135004	EVR 1/4 22 5 SA BS OO M
 1272126004	
1272136004	EVR 1/8 22 6 SA RC CC M
1272136004	EVR 1/4 22 6 SA RC CC M
 1272126005	
1272136005	EVR 1/8 22 6 SA RC CA M
1272136005	EVR 1/4 22 6 SA RC CA M
 1272126006	
1272136006	EVR 1/8 22 6 SA RC CP M
1272136006	EVR 1/4 22 6 SA RC CP M

TECHNICAL DATA

Working pressure 0÷10 Bar (0÷1,00 MPa)

Actuating pressure separate air supply
5/2= 0,5÷10 Bar (0,05÷1,00 MPa)
5/3= 2÷10 Bar (0,20÷1 MPa)

Manual override Monostable

Weight 0,178 kg

Coil is supplied separately page 2.60

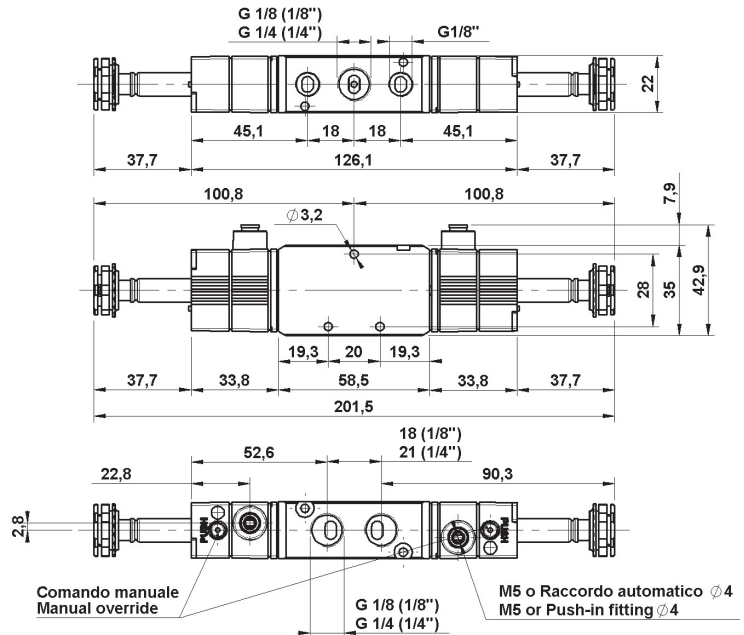

WATER PREPARATION

LINE 127 VPR 1/8"-1/4" | PNEUMATIC VALVES

3/2 SINGLE PNEUMATIC VALVES



	CODE	REFERENCES
	1272223001	VPR 1/8" 22 3 PN PM NC M
	1272233001	VPR 1/4" 22 3 PN PM NC M
	1272223002	VPR 1/8" 22 3 PN PM NO M
	1272233002	VPR 1/4" 22 3 PN PM NO M

TECHNICAL DATA

Working pressure 1±10 Bar (0,10±1,00 MPa)

Pilot operating pressure 1±10 Bar (0,10±1,00 MPa)

Weight 0,130 kg

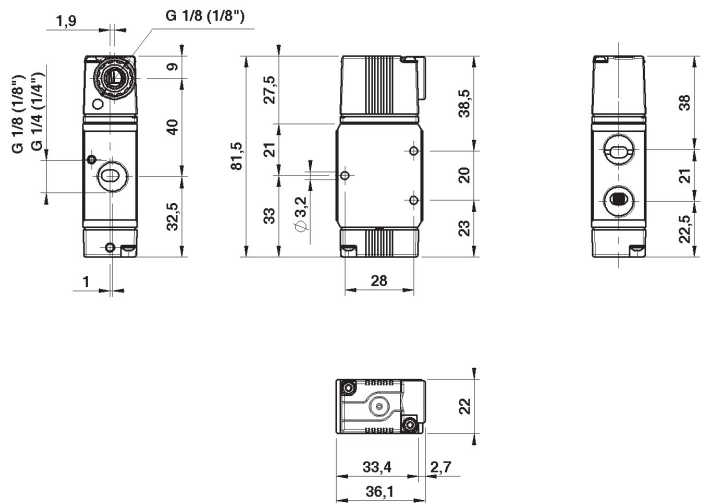

AIR PREPARATION

VALVES

CYLINDERS

FITTINGS

WATER PREPARATION

3/2 DOUBLE PNEUMATIC VALVES



	CODE	REFERENCES
	1272223003	VPR 1/8" 22 3 PN BS OO M
	1272233003	VPR 1/4" 22 3 PN BS OO M
	1272224004	VPR 1/8" 22 3 PN DF OO M
	1272234004	VPR 1/4" 22 3 PN DF OO M

TECHNICAL DATA

Working pressure 0±10 Bar (0±1,00 MPa)

Pilot operating pressure 0,5±10 Bar (0,05±1,00 MPa)

Weight 0,155 kg

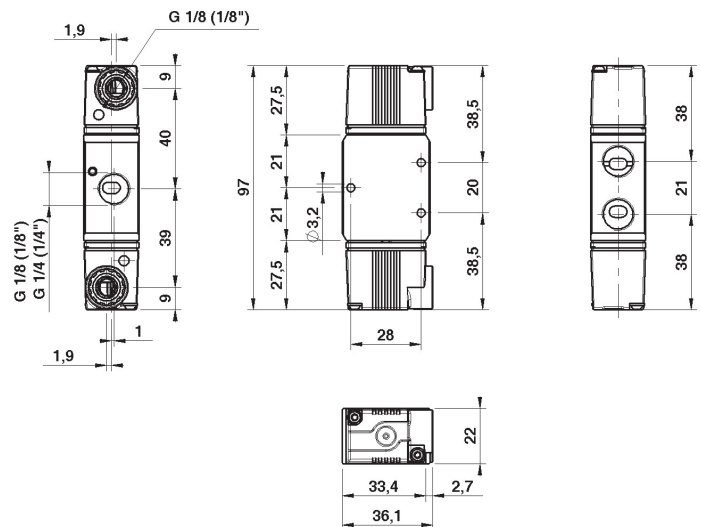

LINE 127 VPR 1/8"-1/4" | PNEUMATIC VALVES

AIR PREPARATION

5/2 SINGLE PNEUMATIC VALVES



	CODE	REFERENCES
	1272225001	VPR 1/8" 22 5 PN PM OO M
	1272235001	VPR 1/4" 22 5 PN PM OO M

TECHNICAL DATA

Working pressure 1+10 Bar (0,10+1,00 MPa)

Pilot operating pressure 1+10 Bar (0,10+1,00 MPa)

Weight 0,137 kg

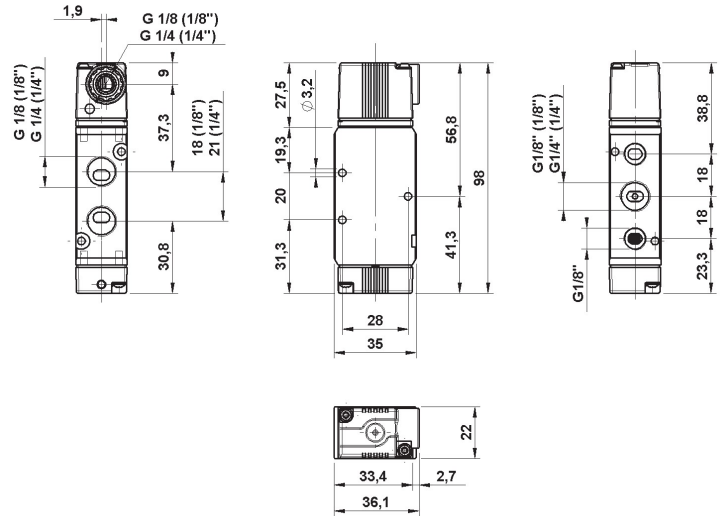

VALVES

CYLINDERS

FITTINGS

5/2 - 5/3 DOUBLE PNEUMATIC VALVES



	CODE	REFERENCES
	1272225002	VPR 1/8" 22 5 PN BS OO M
	1272235002	VPR 1/4" 22 5 PN BS OO M
	1272225003	VPR 1/8" 22 5 PN DF OO M
	1272235003	VPR 1/4" 22 5 PN DF OO M
	1272226001	VPR 1/8" 22 6 PN RC CC M
	1272236001	VPR 1/4" 22 6 PN RC CC M
	1272226002	VPR 1/8" 22 6 PN RC CA M
	1272236002	VPR 1/4" 22 6 PN RC CA M
	1272226003	VPR 1/8" 22 6 PN RC CP M
	1272236003	VPR 1/4" 22 6 PN RC CP M

TECHNICAL DATA

Working pressure 0+10 Bar (0+1,00 MPa)

Pilot operating pressure 5/2= 0,5+10 Bar (0,05+1,00 MPa)

5/3= 2+10 bar (0,20+1 MPa)

Weight 0,161 kg

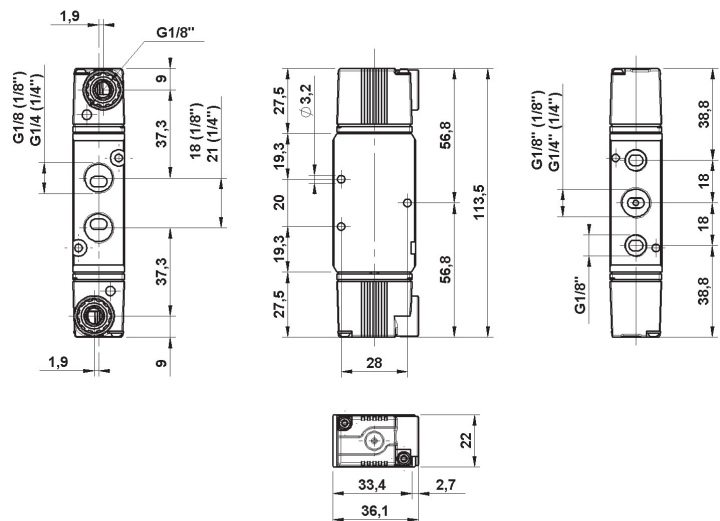

WATER PREPARATION

LINE 127 1/4" | VALVES MANIFOLD



DIMENSIONS

N° TO STATIONS	A	B
2	69	57
3	92	80
4	115	103
5	138	126
6	161	149
7	184	172
8	207	195
9	230	218
10	253	241

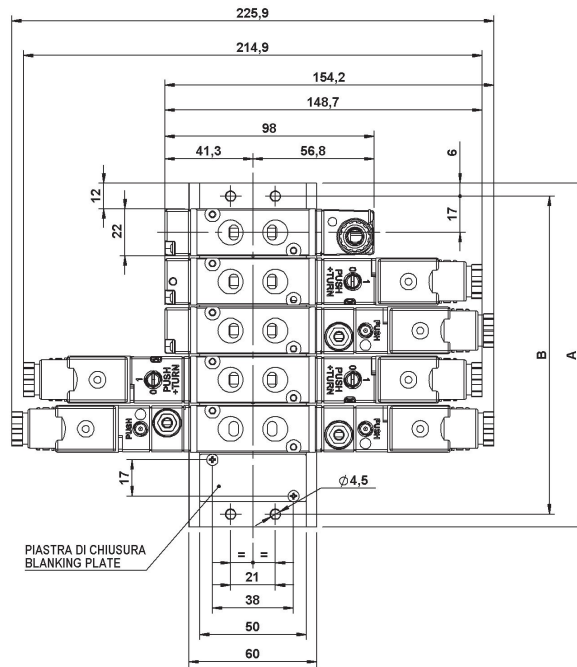
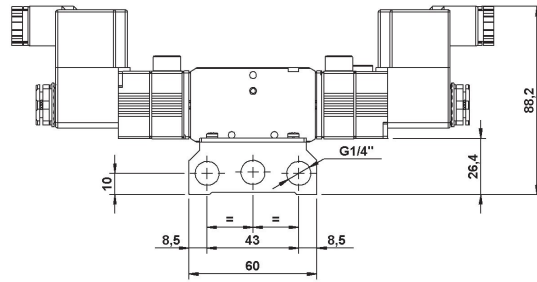

VALVOLA PNEUMATICA
MONOSTABILE

VALVOLA ELETTRO-PNEUMATICA
MONOSTABILE

VALVOLA ELETTRO-PNEUMATICA
MONOSTABILE A.S.*

VALVOLA ELETTRO-PNEUMATICA
BISTABILE

VALVOLA ELETTRO-PNEUMATICA
BISTABILE A.S.*

*A.S.: ALIMENTAZIONE SEPARATA

SEPARATE FEED KIT

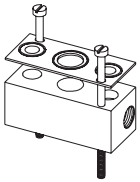

CODE	REF.	LINE
1325C00001	Separate feed KIT	125 -127

BLANKING PLATE KIT



CODE	REF.	LINE
1325A00013	BLANKING PLATE KIT	125 -127 - 128

MANIFOLD



CODE	REF.	LINE
1325A00002	MANIFOLD STB 1/4" 22 2 POS	125 -127 - 128
1325A00003	MANIFOLD STB 1/4" 22 3 POS	125 -127 - 128
1325A00004	MANIFOLD STB 1/4" 22 4 POS	125 -127 - 128
1325A00005	MANIFOLD STB 1/4" 22 5 POS	125 -127 - 128
1325A00006	MANIFOLD STB 1/4" 22 6 POS	125 -127 - 128
1325A00007	MANIFOLD STB 1/4" 22 7 POS	125 -127 - 128
1325A00008	MANIFOLD STB 1/4" 22 8 POS	125 -127 - 128
1325A00009	MANIFOLD STB 1/4" 22 9 POS	125 -127 - 128
1325A00010	MANIFOLD STB 1/4" 22 10 POS	125 -127 - 128

AIR PREPARATION

VALVES

CYLINDERS

FITTINGS

WATER PREPARATION

LINE 120-125-127 | MANIFOLD BARS FOR G1/8"-G1/4" VALVES

AIR PREPARATION

VALVES

CYLINDERS

FITTINGS

WATER PREPARATION

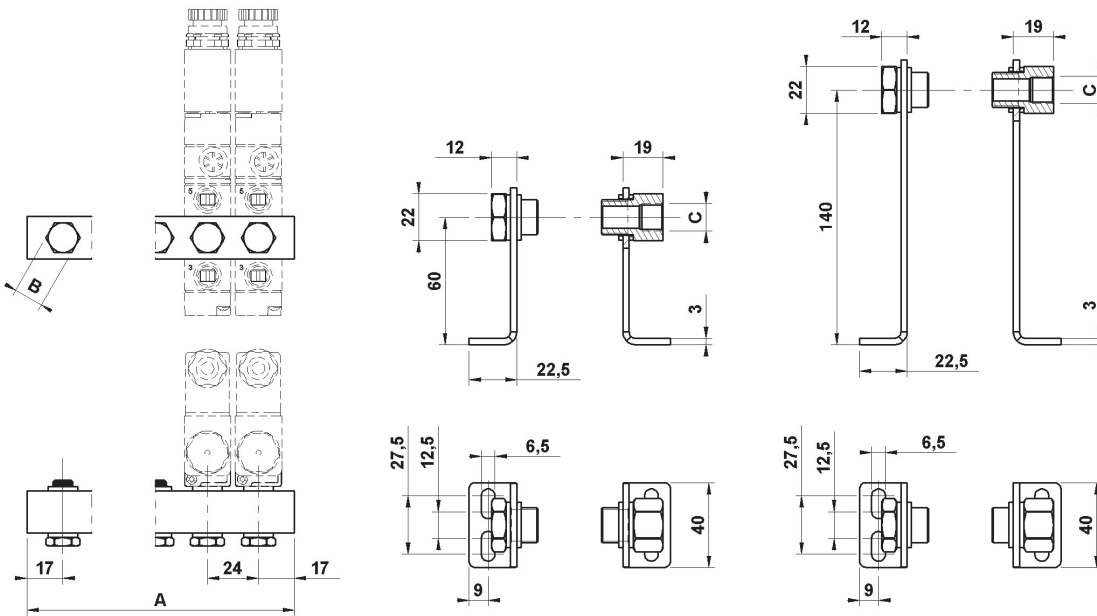

ORDERING CODES		LINE 120 - 125 - 127 G1/8"			LINE 125 - 127 G1/4"			
REF.	CODE	A	B	C	CODE	A	B	C
2 position manifold bar + fitting	1226C00012	58	14		1226C00002	58	17	
3 position manifold bar + fitting	1226C00013	82	14		1226C00003	82	17	
4 position manifold bar + fitting	1226C00014	106	14		1226C00004	106	17	
5 position manifold bar + fitting	1226C00015	130	14		1226C00005	130	17	
6 position manifold bar + fitting	1226C00016	154	14		1226C00006	154	17	
7 position manifold bar + fitting	1226C00017	178	14		1226C00007	178	17	
8 position manifold bar + fitting	1226C00018	202	14		1226C00008	202	17	
High bracket kit	1226C00019			G1/4"	1226C00009			G3/8"
Low bracket kit	1226C00020			G1/4"	1226C00010			G3/8"

LINE 128 EV8 1/4" | SOLENOID AND PNEUMATIC VALVES



AIR PREPARATION

VALVES

CYLINDERS

FITTINGS

WATER PREPARATION

GENERAL FEATURES

Construction	spool valve
Body size	22mm
Body material	aluminium
Single use	YES
Manifold use	YES
Available functions	3/2; 5/2; 5/3

GENERAL TECHNICAL DATA

Fluid	filtered air with or without lubrication
Connections	1/4"
Temperature Range	-5 / +50°C (23 / 122°F) Please note: Below 3°C the air of the circuit must be free from humidity
Reference Flow Rate	P1= 6 bar; Δ P= 1 bar; 3/2= 1.000 l/min; 5/2= 1.000 l/min 5/3= 650 l/min (CC); 550 l/min (CA); 500 l/min (CP)

GUIDE TO REFERENCES

EV8 1/4" 22 3 SL PM NC M

Product	EV8 = Solenoid valves VP8 = Pneumatic valves	Material	M = Metal
Connection	1/4" = G1/4"	Option	NC = Normally closed NO = Normally opened CC = Closed centres CA = Opened centres CP = Pressure centres OO = 5/2
Size	22 = 22 mm	Function	3 = 3/2 5 = 5/2 6 = 5/3
Return	PM = Pneum. mech. spring BS = Bistable RC = Return to centre	Operation	SL = Solenoid PN = Pneumatic

HOW ORDERING A SOLENOID VALVE WITH COIL:

Step 1. Choose the valve without coil

Example of a valve without coil: cod. 1282135001 ref. EV8 1/4" 22 3 SL PM NC M

Step 2. Replace the 8th digit with the number corresponding to the required voltage

1 2 8 2 1 3 5 0 1

0	= Valve without coil
1	= 12V DC
2	= 24V DC
6	= 24V AC
7	= 110V AC
8	= 220V AC

Example of valve with coil: cod. 1282135201 ref. EV8 1/4" 22 3 SL PM NC M 24VDC

USED MATERIALS

- | | |
|---|-------------------------------------|
| 1. Operator - Brass, Stainless steel | 7. Piston gasket - NBR |
| 2. Operator body - PARA+FV | 8. Spool gasket - NBR |
| 3. Body valve - Aluminium | 9. Spool - Aluminium |
| 4. End cap gasket - NBR | 10. Ring - POM |
| 5. Base command - PA+FV | 11. Spring - Stainless steel |
| 6. Piston - POM | |

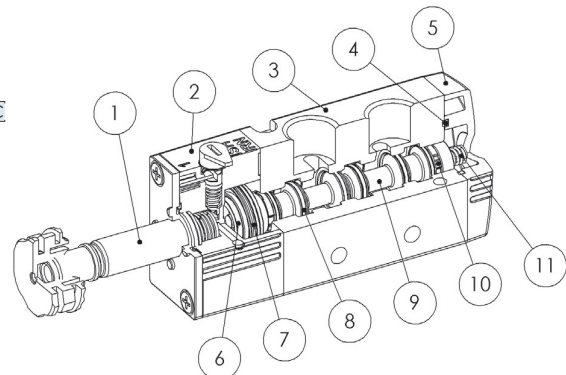

LINE 128 EV8 1/4" | SOLENOID VALVES

AIR PREPARATION

3/2 SINGLE SOLENOID VALVES



VALVES

	CODE	REFERENCES
	1282133001	EV8 1/4" 22 3 SL PM NC M
	1282133002	EV8 1/4" 22 3 SL PM NO M

TECHNICAL DATA

Working pressure 1±10 Bar (0,10±1,00 MPa)

Voltage 24DC, 24V AC, 110V, 220V AC

Manual override Mono-bistabile

Weight 0,125 kg

Coil is supplied separately page 2.60

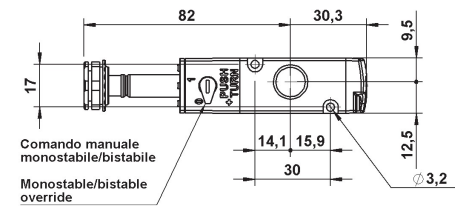
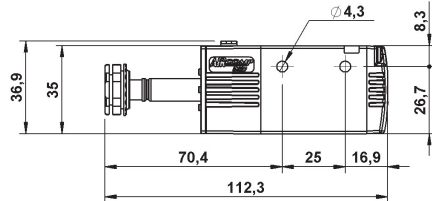
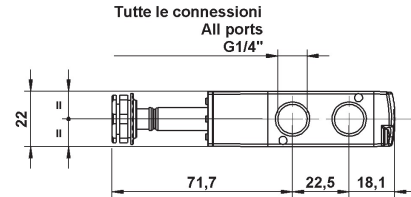

CYLINDERS

FITTINGS

3/2 DOUBLE SOLENOID VALVES



WATER PREPARATION

	CODE	REFERENCES
	1282133003	EV8 1/4" 22 3 SL BS OO M

TECHNICAL DATA

Working pressure 1±10 Bar (0,10±1,00 MPa)

Voltage 24DC, 24V AC, 110V, 220V AC

Manual override Mono-bistabile

Weight 0,162 kg

Coil is supplied separately page 2.60

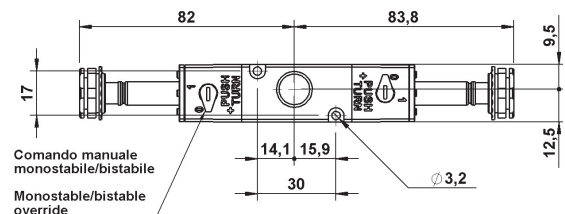
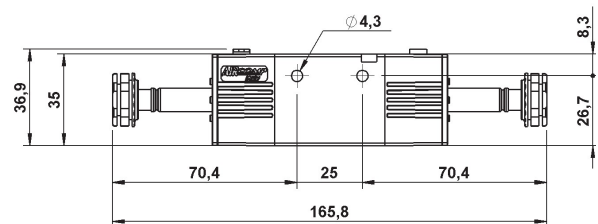
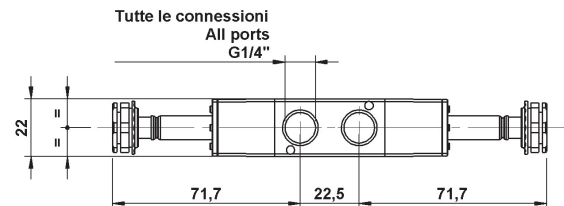

LINE 128 EV8 1/4" | SOLENOID VALVES

5/2 SINGLE SOLENOID VALVES



	CODE	REFERENCES
	1282135001	EV8 1/4" 22 5 SL PM OO M

TECHNICAL DATA

Working pressure 1÷10 Bar (0,10÷1,00 MPa)

Voltage 24DC, 24V AC, 110V, 220V AC

Manual override Mono-bistable

Weight 0,130 kg

Coil is supplied separately page 2.60

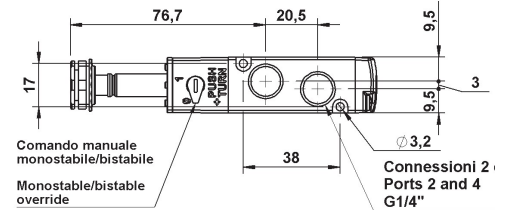
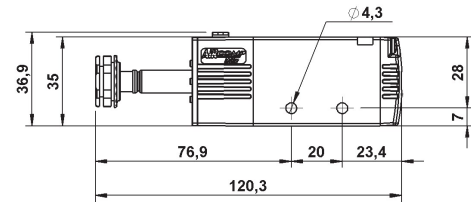
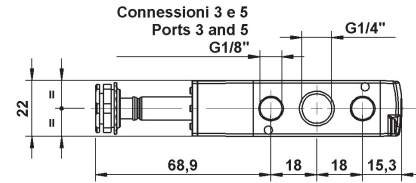

5/2 - 5/3 DOUBLE SOLENOID VALVES



	CODE	REFERENCES
	1282135002	EV8 1/4" 22 5 SL BS OO M
	1282136001	EV8 1/4" 22 6 SL RC CC M
	1282136002	EV8 1/4" 22 6 SL RC CA M
	1282136003	EV8 1/4" 22 6 SL RC CP M

TECHNICAL DATA

Working pressure 5/2= 1÷10 Bar (0,1÷1,00 MPa)
5/3= 1,5÷10 Bar (0,15÷1,00 MPa)

Voltage 24DC, 24V AC, 110V, 220V AC

Manual override Mono-bistable

Weight 0,176 kg

Coil is supplied separately page 2.60

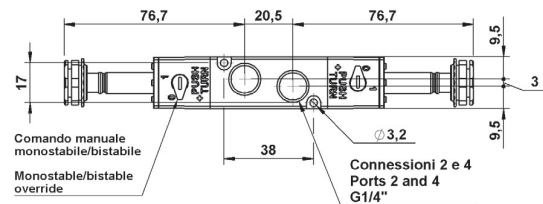
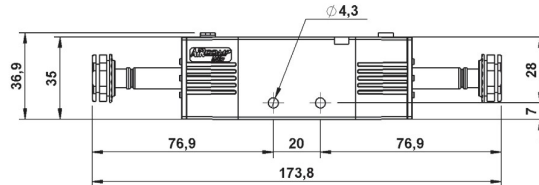
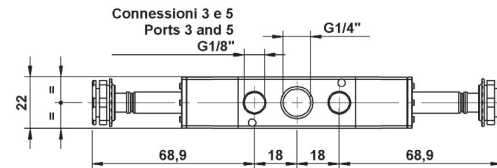

AIR PREPARATION

VALVES

CYLINDERS

FITTINGS

WATER PREPARATION

LINE 128 VP8 1/4" | PNEUMATIC VALVES

AIR PREPARATION

VALVES

3/2 SINGLE PNEUMATIC VALVES



	CODE	REFERENCES
	1282233001	VP8 1/4" 22 3 PN PM NC M
	1282233002	VP8 1/4" 22 3 PN PM NO M

TECHNICAL DATA

Working pressure 1÷10 Bar (0,10÷1,00 MPa)

Pilot pressure at 1 bar = 1 bar

Pilot pressure at 10 bar = 4 bar

Weight 0,120 kg

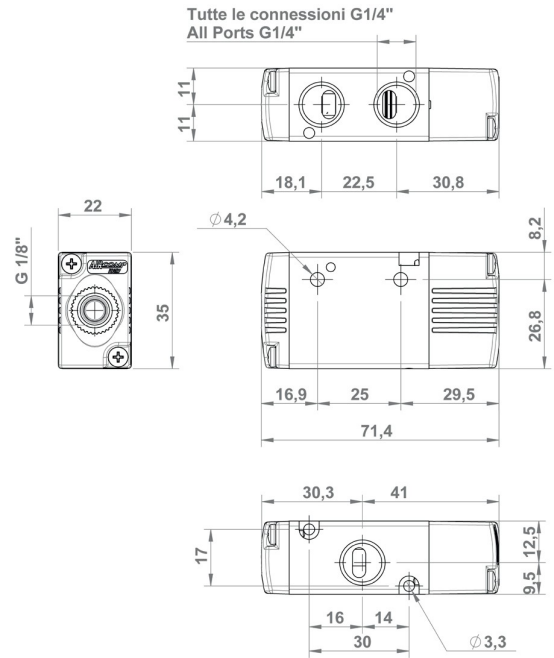

CYLINDERS

FITTINGS

3/2 DOUBLE PNEUMATIC VALVES

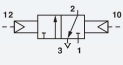

	CODE	REFERENCES
	1282233003	VP8 1/4" 22 3 PN BS OO M

TECHNICAL DATA

Working pressure 1÷10 Bar (0,10÷1,00 MPa)

Pilot operating pressure 0,5÷10 Bar (0,05÷1,00 MPa)

Weight 0,144 kg

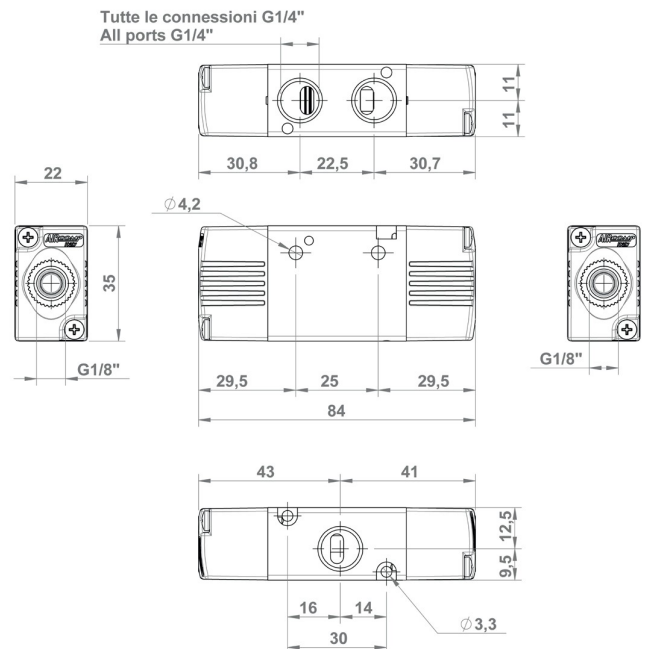

WATER PREPARATION

LINE 128 VP8 1/4" | PNEUMATIC VALVES

5/2 SINGLE PNEUMATIC VALVES



CODE	REFERENCES
1282235001	VP8 1/4" 22 5 PN PM OO M

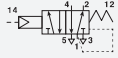

TECHNICAL DATA

Working pressure 1÷10 Bar (0,10÷1,00 MPa)

Pilot pressure at 1 bar = 1 bar

Pilot pressure at 10 bar = 4 bar

Weight 0,137 kg

Connessioni 3 e 5 G1/8"
Ports 3 and 5 G1/8"

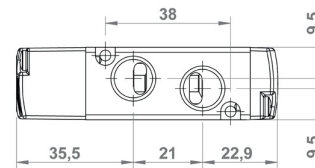
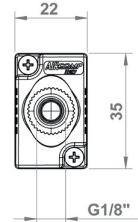
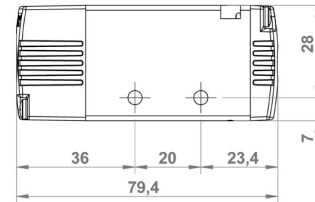
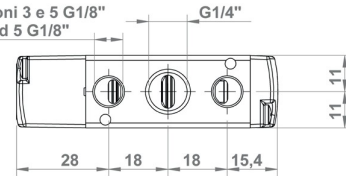

5/2 - 5/3 DOUBLE PNEUMATIC VALVES



CODE	REFERENCES
1282235002	VP8 1/4" 22 5 PN BS OO M
1282236001	VP8 1/4" 22 6 PN RC CC M
1282236002	VP8 1/4" 22 6 PN RC CA M
1282236003	VP8 1/4" 22 6 PN RC CP M

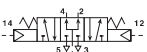
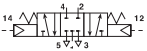
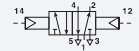

TECHNICAL DATA

Working pressure 1÷10 Bar (0,10÷1,00 MPa)

Pilot operating pressure 5/2=1÷10 Bar (0,1÷1,00 MPa)

5/3=1,5÷10 Bar (0,15÷1,00 MPa)

Weight 0,161 kg

Connessioni 3 e 5 G1/8"
Ports 3 e 5 G1/8"

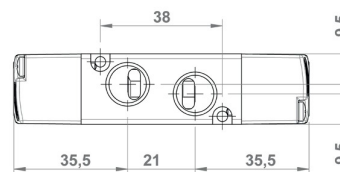
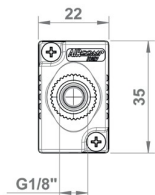
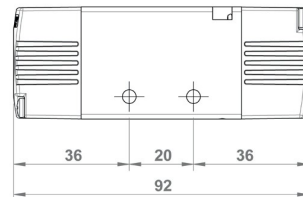
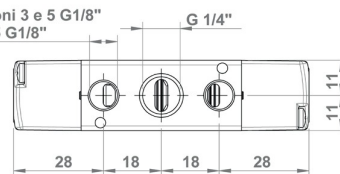

AIR PREPARATION

VALVES

CYLINDERS

FITTINGS

WATER PREPARATION

LINE 130 1/2" | SOLENOID AND PNEUMATIC VALVES



GENERAL FEATURES

Construction	spool valve
Body size	30mm
Body material	aluminium
Single use	YES
Manifold use	YES
Available functions	3/2; 5/2; 5/3

GENERAL TECHNICAL DATA

Fluid	filtered air with or without lubrication
Fissaggio	single and manifold
Connections	1/2"
Temperature Range	-5 / +50°C (23 / 122°F) Please note: Below 3°C the air of the circuit must be free from humidity
Reference Flow Rate	P1= 6 bar; Δ P= 1 bar; 3/2= 3,000 l/min, 5/2= 2,500 l/min, 5/3= 2,500 l/min

GUIDE TO REFERENCES

EV 1/2" 30 3 SL ML NC M

Product

EV = Solenoid valves
VP = Pneumatic valves

Connection

1/2" = G1/2"

Size

30 = 30 mm

Function

3 = 3/2
5 = 5/2
6 = 5/3

Operation

PN = Pneumatic
SL = Solenoid
SA = Assisted solenoid

Material

M = Metal

Option

NC = Normally closed
NO = Normally opened
CC = Closed centres
CA = Opened centres
CP = Pressure centre
OO = 5/2

Return

ML = Spring
PM = Pneum. mech. spring
BS = Bistable
MP = Pneumatic spring
RC = Return to centre
ST = Stable on 3 position

HOW ORDERING A SOLENOID VALVE WITH COIL:

Step 1. choose the valve without coil

Example of a valve without coil: cod. 1304153001 ref. EV 1/2" 30 3 SL ML NC M

Step 2. Replace the 8th digit with the number corresponding to the required voltage

1 3 0 4 1 5 3 0 1

- 0** = Valve without coil
- 1** = 12V DC
- 2** = 24V DC
- 6** = 24V AC
- 7** = 110V AC
- 8** = 220V AC

Example of valve with coil: cod. 1304153201 ref. EV 1/2" 30 3 SL ML NC M 24VDC

USED MATERIALS

- | | |
|---|----------------------------------|
| 1. Operator - Brass, Stainless steel | 5. Base command - POM |
| 2. Operator body - POM | 6. Piston - POM |
| 3. Gasket - NBR | 7. Body valve - Aluminium |
| 4. Spool - Aluminium | 8. Spool gasket - NBR |

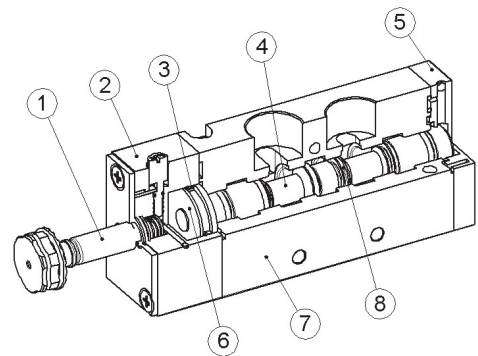

LINE 130 EV 1/2" | SOLENOID VALVES

AIR PREPARATION

VALVES

CYLINDERS

FITTINGS

WATER PREPARATION

3/2 SINGLE SOLENOID VALVES



	CODE	REFERENCES
	1304153001	EV 1/2" 30 3 SL PM NC M
	1304153002	EV 1/2" 30 3 SL PM NO M

TECHNICAL DATA

Connection size G1/2"

Working pressure 2+8 Bar (0,20+0,80 MPa)

Manual override Mono - bistable

Weight 0,278 kg

Coil is supplied separately page 2.60

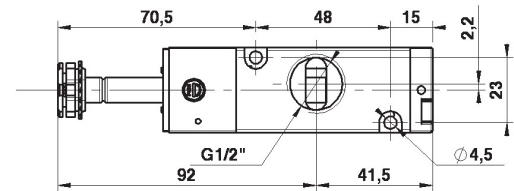
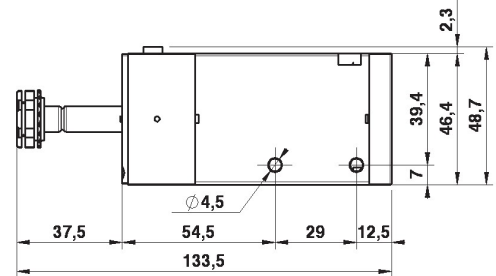
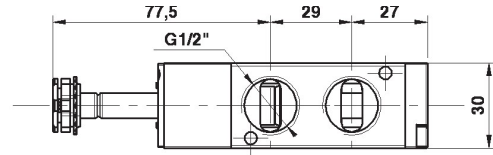

3/2 DOUBLE SOLENOID VALVES



	CODE	REFERENCES
	1304153003	EV 1/2" 30 3 SL BS OO M

TECHNICAL DATA

Connection size G1/2"

Working pressure 2+8 Bar (0,20+0,80 MPa)

Manual override Mono - bistable

Weight 0,288 kg

Coil is supplied separately page 2.60

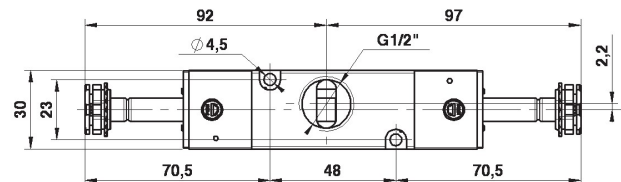
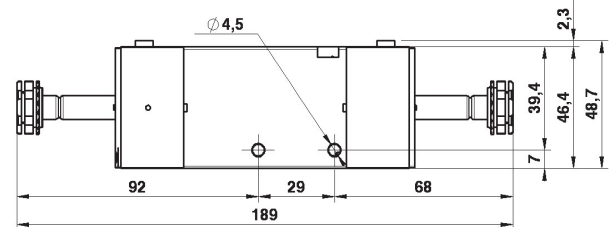
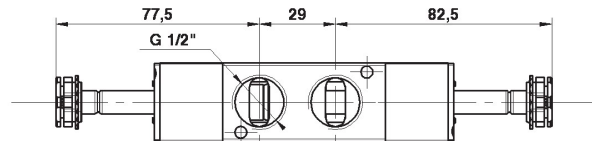

LINE 130 EV 1/2" | SOLENOID VALVES

5/2 SINGLE SOLENOID VALVES



CODE	REFERENCES
1304155001	EV 1/2" 30 5 SL PM OO M

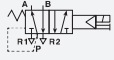

TECHNICAL DATA

Connection size G1/2"

Working pressure 2÷8 Bar (0,20÷0,80 MPa)

Manual override Mono - bistable

Weight 0,344 kg

Coil is supplied separately page 2.60

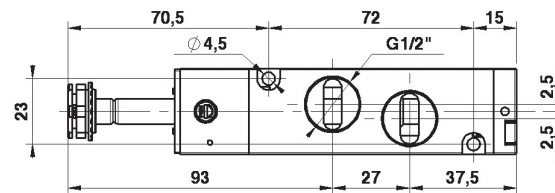
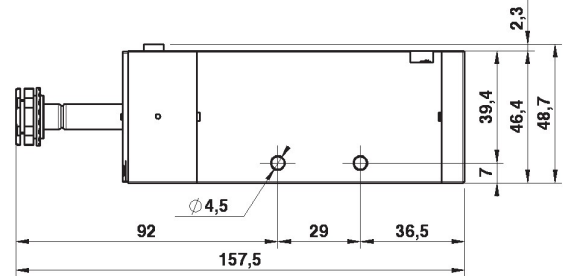
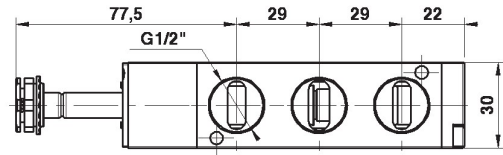

5/2 DOUBLE SOLENOID VALVES



CODE	REFERENCES
1304155002	EV 1/2" 30 5 SL BS OO M



TECHNICAL DATA

Connection size G1/2"

Working pressure 2÷8 Bar (0,20÷0,80 MPa)

Manual override Mono - bistable

Weight 0,354 kg

Coil is supplied separately page 2.60

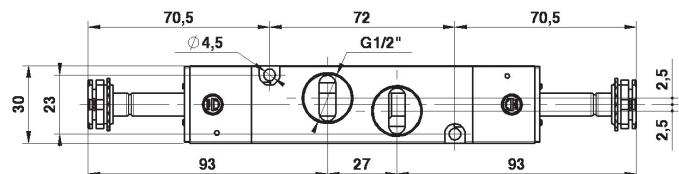
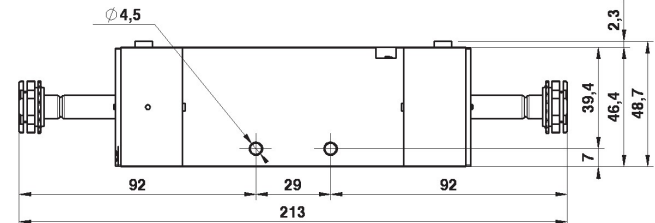
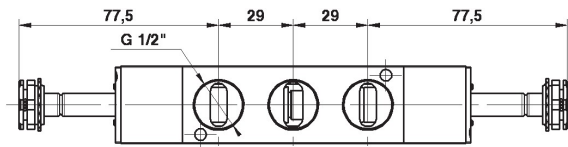

AIR PREPARATION

VALVES

CYLINDERS

FITTINGS

WATER PREPARATION

LINE 130 EV 1/2" | SOLENOID VALVES

AIR PREPARATION

5/3 SOLENOID VALVES



VALVES

	CODE	REFERENCES
	1304156001	EV 1/2" 30 6 SL RC CC M
	1304156002	EV 1/2" 30 6 SL RC CA M
	1304156003	EV 1/2" 30 6 SL RC CP M

CYLINDERS

TECHNICAL DATA

Connection size G1/2"

Working pressure 3÷8 Bar (0,30÷0,80 MPa)

Manual override Mono-bistable

Weight 0,617 kg

Coil is supplied separately page 2.60

FITTINGS

PILOT ASSISTED 3/2 SINGLE SOLENOID VALVES



WATER PREPARATION

	CODE	REFERENCES
	1304153004	EV 1/2" 30 3 SA PM NC M
	1304153005	EV 1/2" 30 3 SA PM NO M

TECHNICAL DATA

Connection size G1/2"

Working pressure 3÷8 Bar (0,30÷0,80 MPa)

Working pressure (separate air only)
2÷8 Bar (0,20÷0,80 MPa)

Manual override Mono - bistable

Weight 0,274 kg

Coil is supplied separately page 2.60

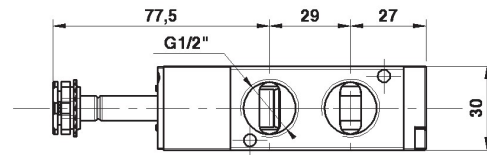
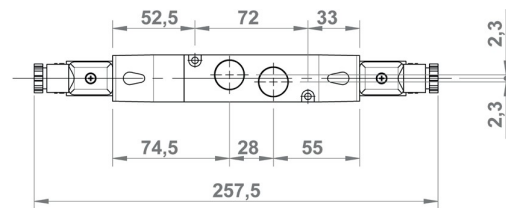
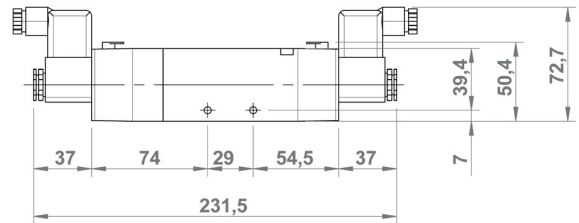
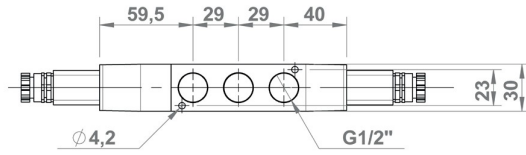

TUBO 6x4
PIPE 6x4

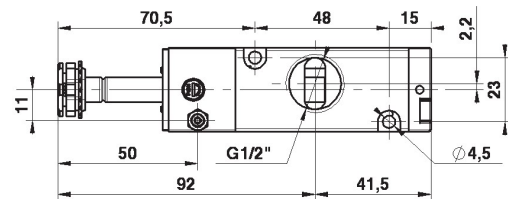
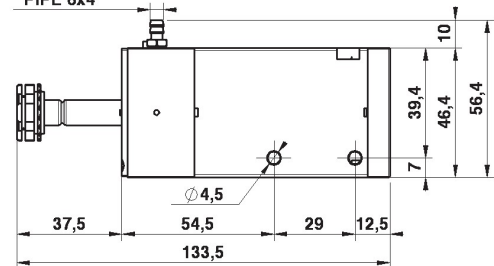

LINE 130 EV 1/2" | SOLENOID VALVES

PILOT ASSISTED 3/2 DOUBLE SOLENOID VALVES



CODE	REFERENCES
1304153006	EV 1/2" 30 3 SA BS OO M

TECHNICAL DATA

Connection size G1/2"
Working pressure 0÷8 Bar (0÷0,80 MPa)
Working pressure (separate air only) 2÷8 Bar (0,20÷0,80 MPa)
Manual override Mono-bistable
Weight 0,280 kg
Coil is supplied separately page 2.60

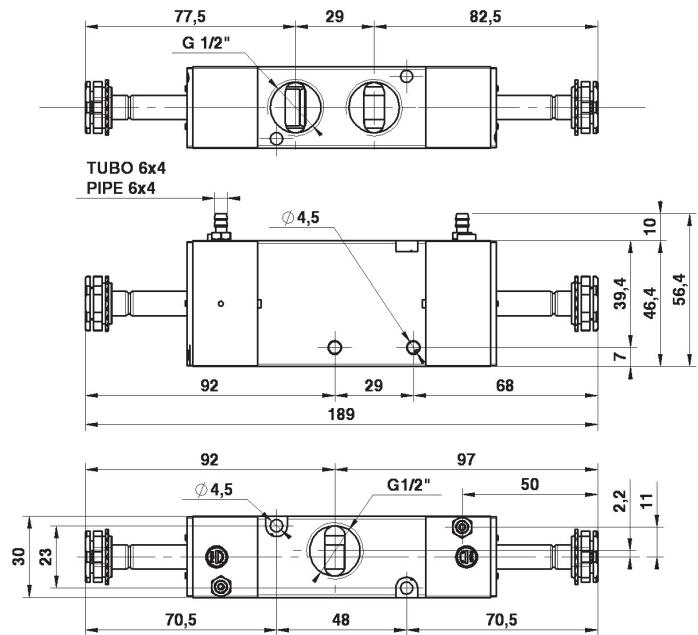

PILOT ASSISTED 5/2 SINGLE SOLENOID VALVES



CODE	REFERENCES
1304155003	EV 1/2" 30 5 SA PM OO M

TECHNICAL DATA

Connection size G1/2"
Working pressure 0÷8 Bar (0÷0,80 MPa)
Working pressure (separate air only) 2÷8 Bar (0,20÷0,80 MPa)
Manual override Mono-bistable
Weight 0,340 kg
Coil is supplied separately page 2.60

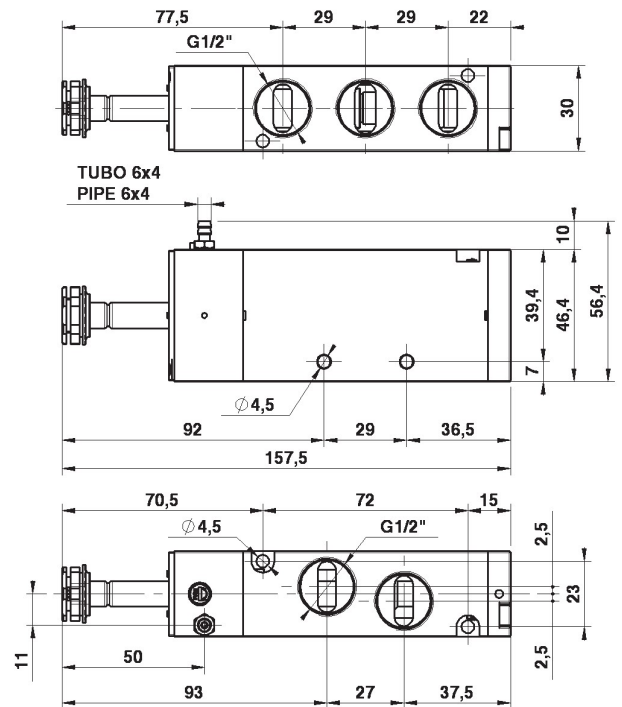

AIR PREPARATION

VALVES

CYLINDERS

FITTINGS

WATER PREPARATION

LINE 130 EV 1/2" | SOLENOID VALVES

AIR PREPARATION

PILOT ASSISTED 5/2 DOUBLE SOLENOID VALVES



VALVES

CODE	REFERENCES
1304155004	EV 1/2" 30 5 SA BS OO M

TECHNICAL DATA

Connection size G1/2"
Working pressure 0÷8 Bar (0÷0,80 MPa)
Working pressure (separate air only) 2÷8 Bar (0,20÷0,80 MPa)
Manual override Mono-bistable
Weight 0,346 kg
Coil is supplied separately page 2.60

CYLINDERS

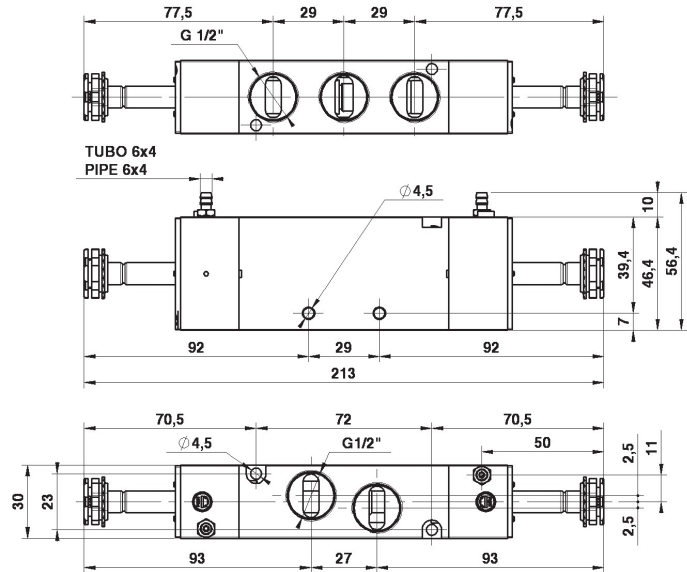

FITTINGS

PILOT ASSISTED 5/3 SOLENOID VALVES

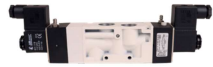

WATER PREPARATION

CODE	REFERENCES
1304156004	EV 1/2" 30 6 SA RC CC M
1304156005	EV1/2 30 6 SA RC CA M
1304156006	EV1/2 30 6 SA RC CP M

TECHNICAL DATA

Connection size G1/2"
Working pressure 3÷8 Bar (0,30÷0,80 MPa)
Working pressure (separate air only) 3÷8 Bar (0,30÷0,80 MPa)
Manual override Mono - bistable
Weight 0,610 kg
Coil is supplied separately page 2.60

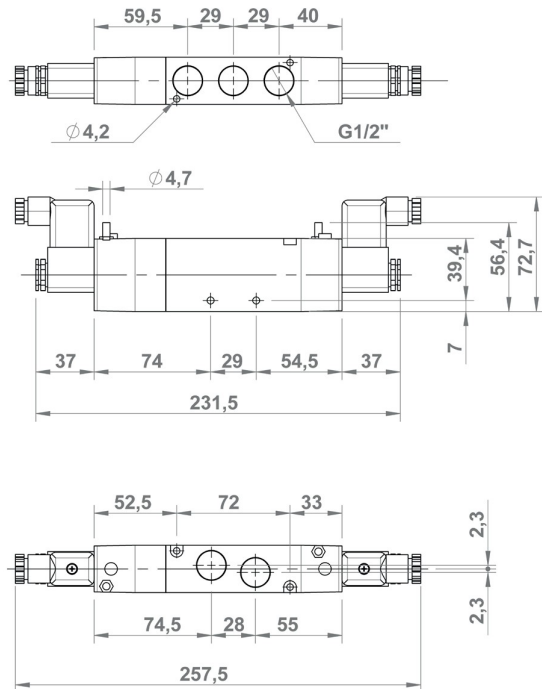

LINE 130 VP 1/2" | PNEUMATIC VALVES

3/2 SINGLE PNEUMATIC VALVES



	CODE	REFERENCES
	1304253001	VP 1/2" 30 3 PN PM NC M
	1304253002	VP 1/2" 30 3 PN PM NO M

TECHNICAL DATA

Connection size G1/2"

Working pressure 2÷8 Bar (0,20÷0,80 MPa)

Operating pressure 1,50÷8 bar (0,15÷0,80 MPa)

Weight 0,300 kg

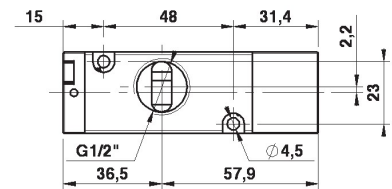
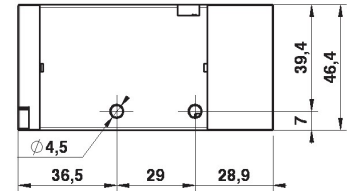
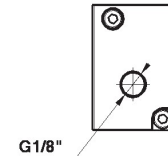
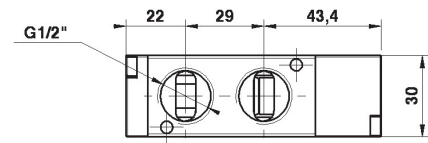

3/2 DOUBLE PNEUMATIC VALVES



	CODE	REFERENCES
	1304253003	VP 1/2" 30 3 PN BS O O M

TECHNICAL DATA

Connection size G1/2"

Working pressure 0÷8 Bar (0÷0,80 MPa)

Operating pressure 1,50÷8 Bar (0,15÷0,80 MPa)

Weight 0,321 kg

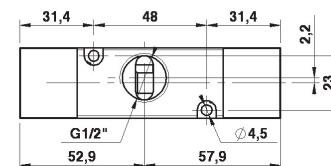
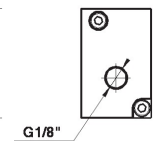
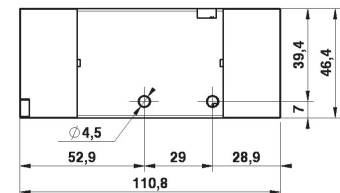
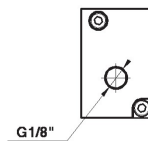
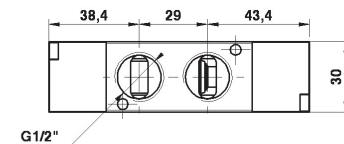

AIR PREPARATION

VALVES

CYLINDERS

FITTINGS

WATER PREPARATION

LINE 130 VP 1/2" | PNEUMATIC VALVES

AIR PREPARATION

VALVES

CYLINDERS

FITTINGS

WATER PREPARATION

5/2 SINGLE PNEUMATIC PILOT VALVES



CODE	REFERENCES
1304255001	VP 1/2" 30 5 PN PM OO M

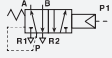

TECHNICAL DATA

Connection size G1/2"

Working pressure 2÷8 Bar (0,20÷0,80 MPa)

Operating pressure 1,50÷8 Bar (0,15÷0,80 MPa)

Weight 0,361 kg

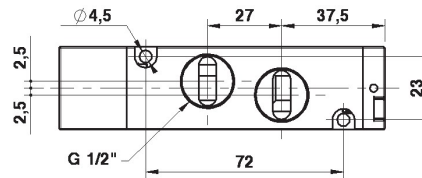
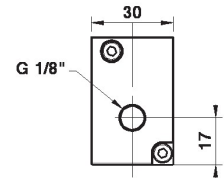
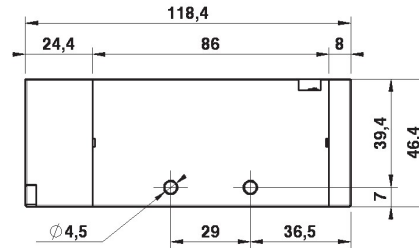
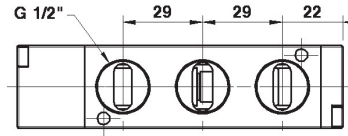

5/2 SINGLE PNEUMATIC PILOT VALVES BISTABLE



CODE	REFERENCES
1304255002	VP 1/2" 30 5 PN BS OO M

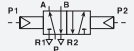

TECHNICAL DATA

Connection size G1/2"

Working pressure 0÷8 Bar (0÷0,80 MPa)

Operating pressure 1,50÷8 Bar (0,15÷0,80 MPa)

Weight 0,381 kg

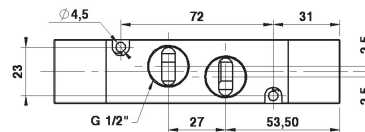
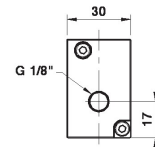
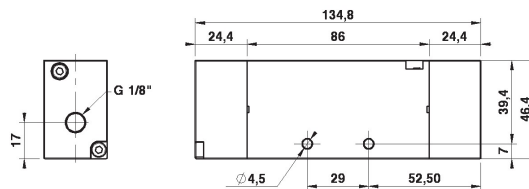
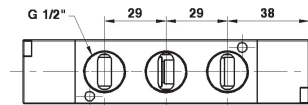

LINE 130 VP 1/2" | PNEUMATIC VALVES

5/3 SINGLE PNEUMATIC PILOT VALVES



	CODE	REFERENCES
	1304256001	VP 1/2" 30 6 PN RC CC M
	1304256002	VP 1/2" 30 6 PN RC CA M
	1304256003	VP 1/2" 30 6 PN RC CP M

TECHNICAL DATA

Connection size G1/2"

Working pressure 0÷8 Bar (0÷0,80 MPa)

Operating pressure 1,50÷8 bar (0,15÷0,80 MPa)

Weight 0,643 kg

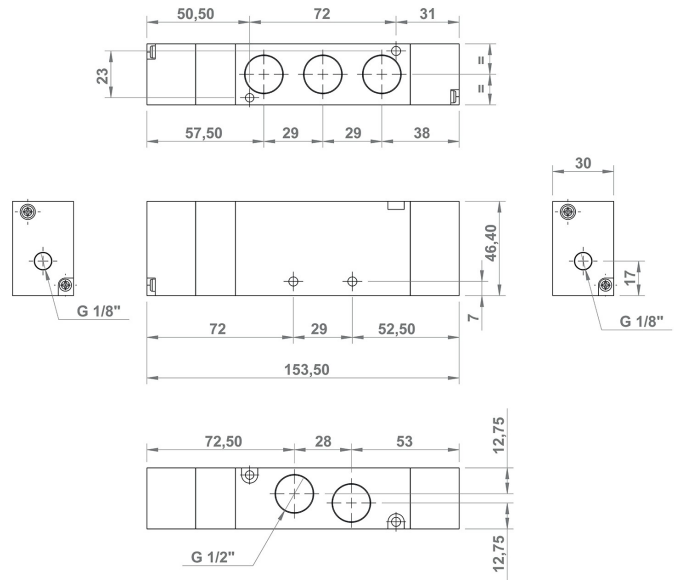

AIR PREPARATION

VALVES

CYLINDERS

FITTINGS

WATER PREPARATION

LINE 130 EV 1/2" | 1/2" VALVES MANIFOLD

AIR PREPARATION

VALVES

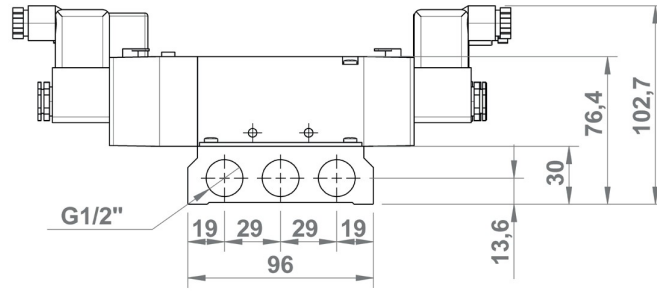

DIMENSIONS

N° OF STATIONS	A	B
2	81	71
3	112	102
4	143	133
5	174	164
6	205	195
7	236	226
8	267	257
9	298	288
10	329	319

CYLINDERS

FITTINGS

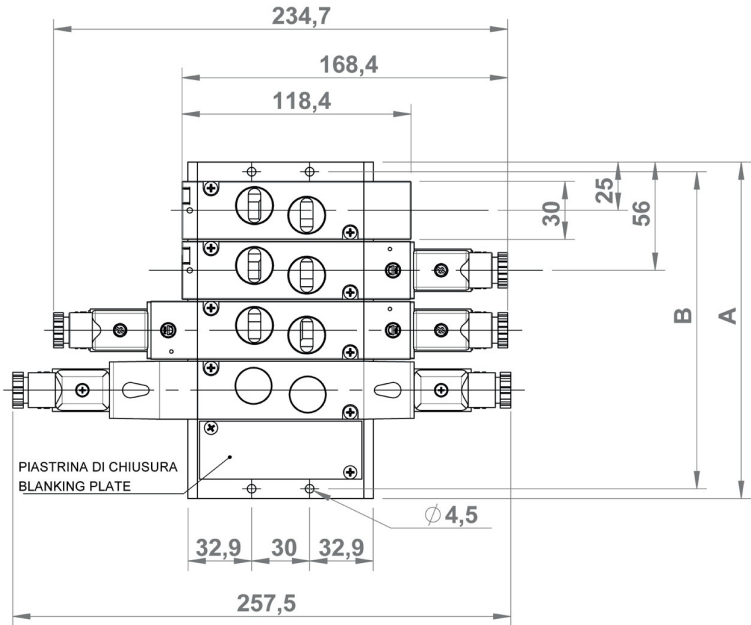

MANIFOLD



CODE	REF.	LINEA
1345A00002	MANIFOLD STB 1/2" 30 2 POS	130 -1/2"
1345A00003	MANIFOLD STB 1/2" 30 3 POS	130 -1/2"
1345A00004	MANIFOLD STB 1/2" 30 4 POS	130 -1/2"
1345A00005	MANIFOLD STB 1/2" 30 5 POS	130 -1/2"
1345A00006	MANIFOLD STB 1/2" 30 6 POS	130 -1/2"
1345A00007	MANIFOLD STB 1/2" 30 7 POS	130 -1/2"
1345A00008	MANIFOLD STB 1/2" 30 8 POS	130 -1/2"
1345A00009	MANIFOLD STB 1/2" 30 9 POS	130 -1/2"
1345A00010	MANIFOLD STB 1/2" 30 10POS	130 -1/2"

WATER PREPARATION

BLANKING PLATE KIT



CODE	REF.	LINE
1345A00013	BLANKING PLATE KIT	130 -1/2"

SPARE PARTS



CODE	REF.	CONF.
1345A00012	manifold seal 30mm	10 pieces

LINE 130 ISO 5599/1 | SOLENOID VALVES

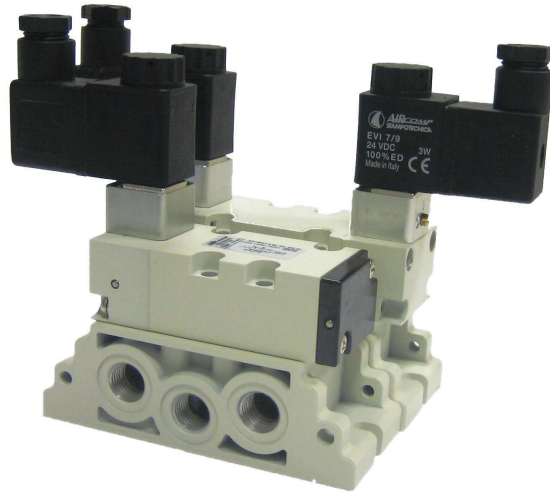

GENERAL FEATURES

Construction	spool valve
Tipo valvola	ISO 5599/1 interface
Body material	aluminium
Single use	NO
Manifold use	ISO 5599/1
Available functions	5/2; 5/3

Note: connectors and coils are supplied separately

GENERAL TECHNICAL DATA

Fluid	filtered air with or without lubrication
Connections	1/4" in manifold
Temperature Range	-5 / +50°C (23 / 122°F)
Reference Flow Rate	P1= 6 bar; Δ P= 1 bar; 1,300l/min

GUIDE TO REFERENCES

EV	ISO1	5	SL	ML	OO	M
Product EV = Solenoid valves			Type ISO1 = ISO 5599/1			Material M = Metal
Function 5 = 5/2 6 = 5/3			Option CC = Closed centres CA = Opened centres CP = Pressure centre OO = 5/2			Return BS = Bistable RC = Return to centre PM = Pneum. mech. spring
Operation SL = Solenoid						

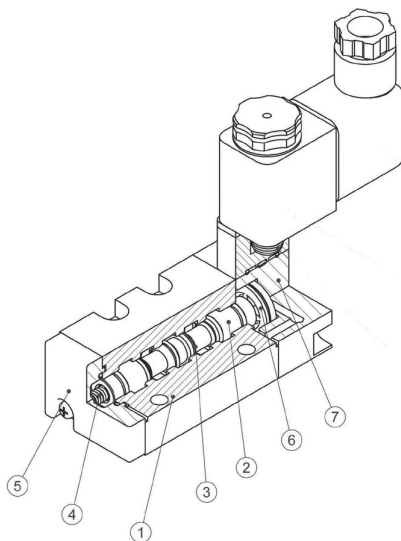

USED MATERIALS

- 1. Body valve** - Aluminium
- 2. Spool** - Aluminium
- 3. Spool gasket** - NBR
- 4. Spring** - Steel
- 5. Base command** - Technopolymer
- 6. Piston** - Technopolymer
- 7. Operator** - Aluminium

AIR PREPARATION

VALVES

CYLINDERS

FITTINGS

WATER PREPARATION

LINE 130 ISO 5599/1 | SOLENOID VALVES

AIR PREPARATION

5/2 SINGLE SOLENOID VALVES



VALVES

CODE	REFERENCES
1308175001	EV ISO1 5 SL PM OO M

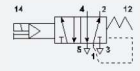

TECHNICAL DATA

Working Pressure 2÷7 Bar (0,20÷0,70 MPa)

Coil is supplied separately page 2.60

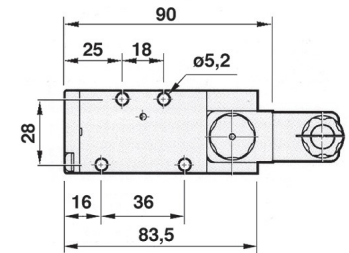
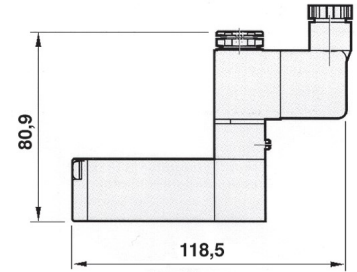
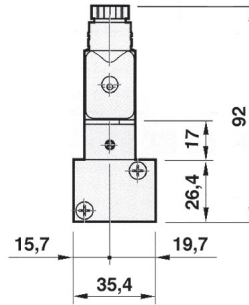

CYLINDERS

FITTINGS

5/2 DOUBLE SOLENOID VALVES



WATER PREPARATION

CODE	REFERENCES
1308175002	EV ISO1 5 SL BS OO M

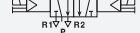

TECHNICAL DATA

Working Pressure 2÷7 Bar (0,20÷0,70 MPa)

Coil is supplied separately page 2.60

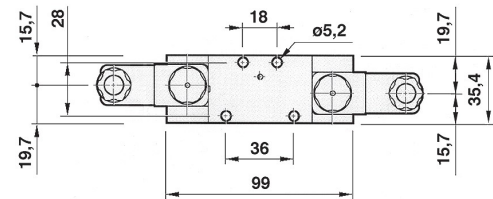
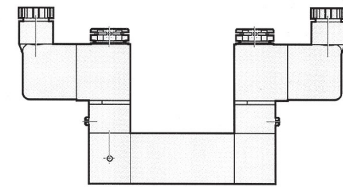
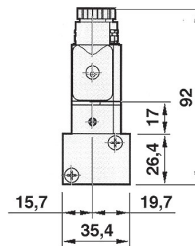

LINE 130 ISO 5599/1 | SOLENOID VALVES

5/3 SOLENOID VALVES

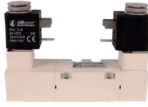

	CODE	REFERENCES
	1308176001	EV ISO1 6 SL RC CC M
	1308176002	EV ISO1 6 SL RC CA M
	1308176003	EV ISO1 6 SL RC CP M

TECHNICAL DATA

Working Pressure 3÷7 Bar (0,30÷0,70 MPa)

Coil is supplied separately page 2.60

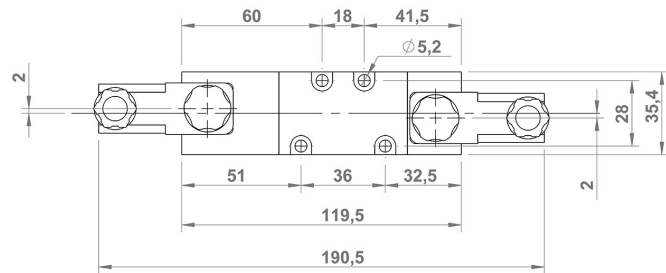
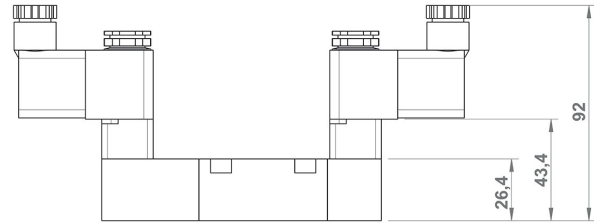

AIR PREPARATION

VALVES

CYLINDERS

FITTINGS

WATER PREPARATION

LINE 130 ISO 5599/1 | SINGLE MANIFOLD

AIR PREPARATION

SINGLE MANIFOLD



CODE	REFERENCES
1355A00001	single manifold side/rear ports

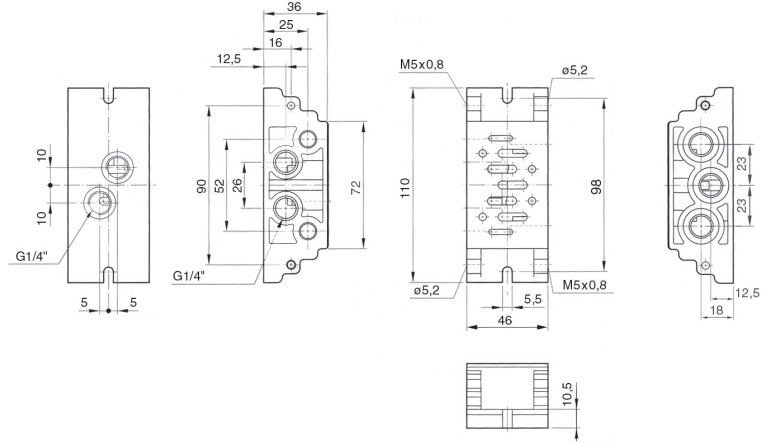

VALVES

CYLINDERS

FITTINGS

SINGLE MANIFOLD FRONT PORTS



CODE	REFERENCES
1355A00005	single manifold front ports

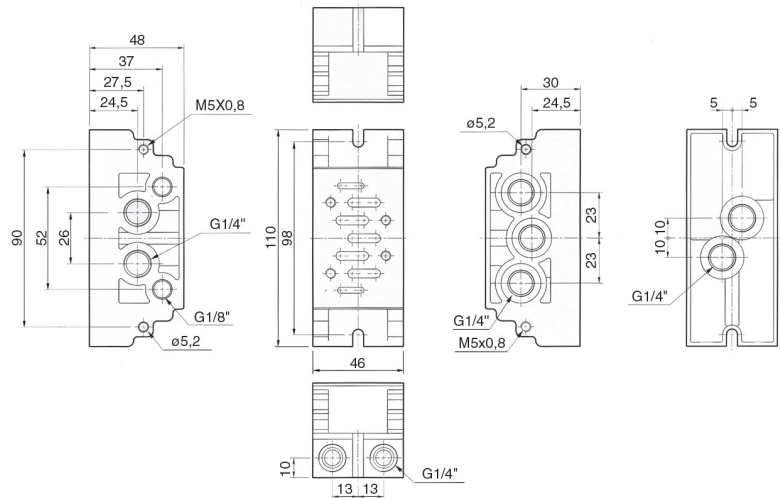

WATER PREPARATION

SPARE SEAL KIT



CODE	REF.	LINE
1355A00003	SPARE SEAL KIT	130

LINE 130 ISO 5599/1 | MODULAR MANIFOLD

MODULAR MANIFOLD



CODE	REFERENCES
1355A00002	modular manifold rear ports

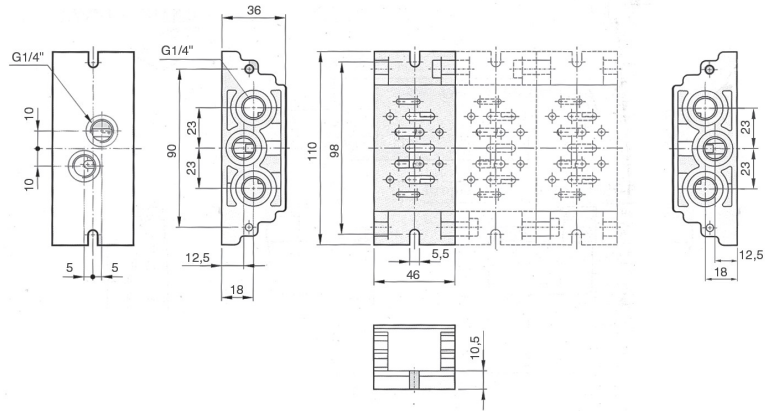

MODULAR MANIFOLD FRONT PORTS



CODE	REFERENCES
1355A00006	modular manifold rear ports

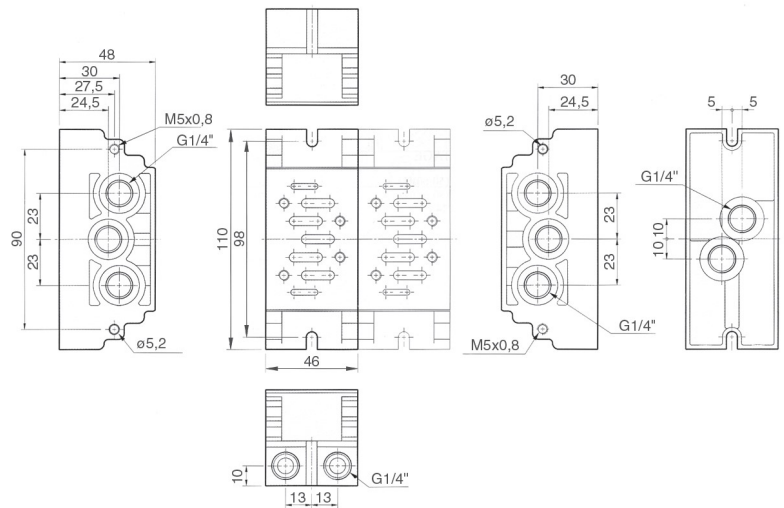

SPARE SEAL KIT



CODE	REF.	LINE
1355A00003	SPARE SEAL KIT	130

AIR PREPARATION

VALVES

CYLINDERS

FITTINGS

WATER PREPARATION

LINE 130 NAMUR | SOLENOID VALVES

AIR PREPARATION

VALVES



CYLINDERS

GENERAL FEATURES

Construction	spool valve
Valve type	NAMUR interface
Body material	aluminium
Single use	on NAMUR interface
Manifold use	NO
Available functions	5/2 monostable/bistable

Note: connectors and coils are supplied separately

GENERAL TECHNICAL DATA

Fluid	filtered air with or without lubrication
Connections	1/4"
Temperature Range	-5 / +50°C (23 / 122°F)
Reference Flow Rate	P1= 6 bar; Δ P= 1 bar; 1.900 l/min

FITTINGS

WATER PREPARATION

GUIDE TO REFERENCES

EV NM 5 SL ML OO M

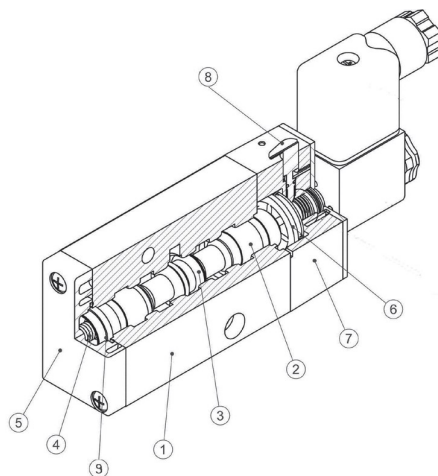
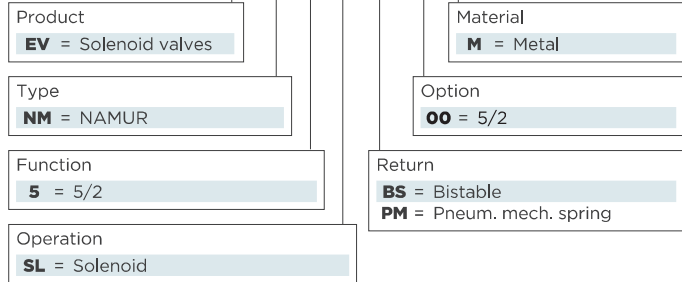

USED MATERIALS

1. **Body valve** - Aluminium
2. **Spool** - Aluminium
3. **Spool gasket** - NBR
4. **Spring** - Steel
5. **Base command** - Technopolymer
6. **Piston** - Technopolymer
7. **Operator** - Aluminium
8. **Manual Override** - Technopolymer
9. **Bush** - Technopolymer

LINE 130 NAMUR | SOLENOID VALVES

5/2 SINGLE SOLENOID VALVES



CODE	REFERENCES
1309135001	EV NM 5 SL PM OO M

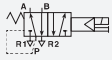

TECHNICAL DATA

Working Pressure 2÷8 Bar (0,20÷0,80 MPa)

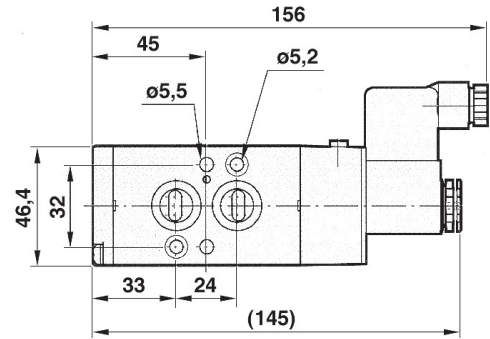
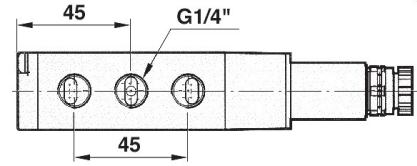
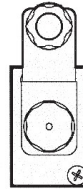

AIR PREPARATION

VALVES

CYLINDERS

FITTINGS

WATER PREPARATION

5/2 DOUBLE SOLENOID VALVES



CODE	REFERENCES
1309135002	EV NM 5 SL BS OO M

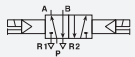

TECHNICAL DATA

Working Pressure 2÷8 Bar (0,20÷0,80 MPa)

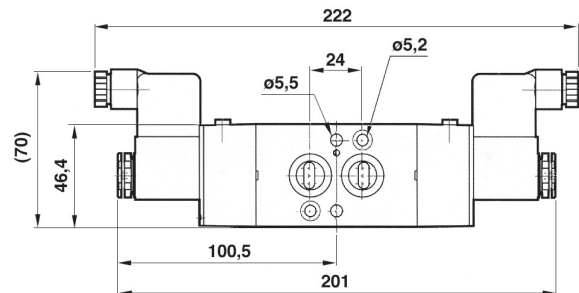
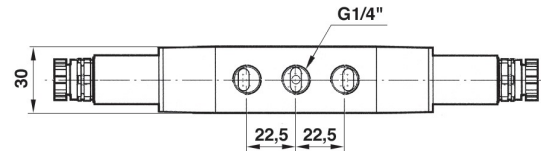
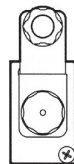

LINE 120-125-127-128-130 | COILS

AIR PREPARATION

VALVES

CYLINDERS

FITTINGS

WATER PREPARATION

22MM COIL

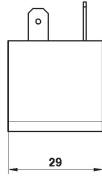
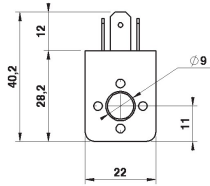
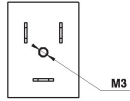

TECHNICAL DATA

Voltage	12V DC, 24V DC, 24V AC, 110V AC, 220V AC
Voltage tolerance	+/- 10%
Power consumption	AC=5VA DC=3,0 W
Duty cycle	ED 100%
Protection with connector	IP 65 EN 60529

CODE	REF.	LINE
A502600018	COIL DC12V	120-125-127-128-130
A502600006	COIL DC24V	120-125-127-128-130
A502600007	COIL AC24V 50/60HZ	120-125-127-128-130
A502600008	COIL AC110V 50/60HZ	120-125-127-128-130
A502600009	COIL AC220V 50/60HZ	120-125-127-128-130

22MM COIL WITH "UL" CERTIFICATION

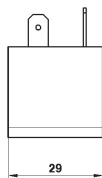
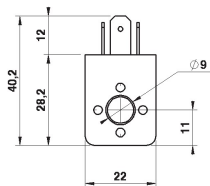
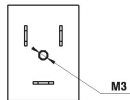

CODE	REF.	LINE
A502600048	"UL" (COIL) DC24V (DC12V)	120-125-127-128-130
A502600049	"UL" (COIL) AC24V (DC12V)	120-125-127-128-130
A502600050	"UL" (COIL) AC110V	120-125-127-128-130
A502600051	"UL" (COIL) AC220V	120-125-127-128-130

EXPLOSION-PROOF COIL WITH CABLE

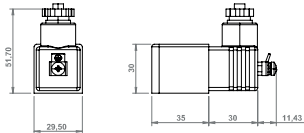

CODE	REF.	LINE
1341A00001	COIL 30x30 mm 24 V DC with cable L3 mt	120-125-127-128-130
1341A00002	COIL 30x30 mm 24 V AC with cable L3 mt	120-125-127-128-130
1341A00003	COIL 30x30 mm 48 V AC with cable L3 mt	120-125-127-128-130
1341A00004	COIL 30x30 mm 220 V AC with cable L3 mt	120-125-127-128-130

LINE 120-125-127-128-130 | CONNECTORS

CONNECTORS

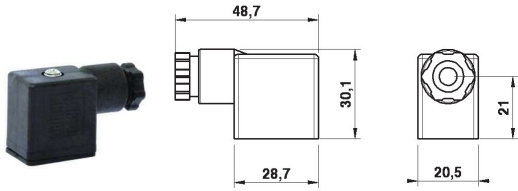

CODE	REF.	LINE
A502600010	CONNECTOR SP 22mm	120-125-127-128-130

* Connector complies UL standard

22MM LED CONNECTORS

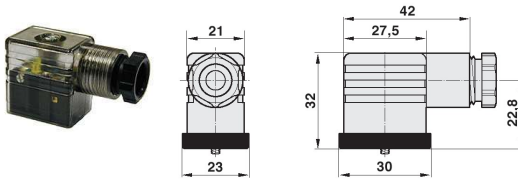

CODE	REF.	LINE
A502600026	LED CONNECTORS 22mm 24V	120-125-127-128-130
A502600027	LED CONNECTORS 22mm 115V	120-125-127-128-130
A502600028	LED CONNECTORS 22mm 230V	120-125-127-128-130

22MM CABLE LED CONNECTORS

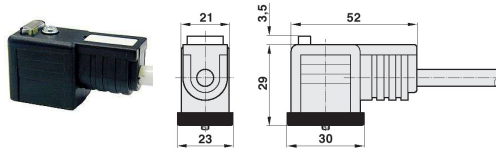

CODE	REF.	LENGHT	LINE
A202600029	LED CONNECTORS 22mm 24V	3mt	120-125-127-128-130
A502600030	LED CONNECTORS 22mm 115V	3mt	120-125-127-128-130
A502600031	LED CONNECTORS 22mm 230V	3mt	120-125-127-128-130

AIR PREPARATION

VALVES

CYLINDERS

FITTINGS

WATER PREPARATION

LINE 150 | MULTIPOLE VALVES

AIR PREPARATION

VALVES

CYLINDERS

FITTINGS

WATER PREPARATION

Valve Line SIM 150 features a flexible and easy assembling, that is typical of valves on manifold, along with the advantages of the electric and pneumatic cabling system belonging to more cutting-edge solutions. A special double solenoid pilot, which is positioned on one side only of the valve, is able to supply even bistable valves, thus remarkably reducing the valve island overall dimensions.

Easy and intuitive assembling system enables a quick mounting of any configuration type, guaranteeing prompt and reliable service.

The comprehensive range of valves and modules available allows realizing true integrated systems up to 20 bistable solenoid valves, so as to meet effectively several application requirements.



SINGLE PILOT POWER

Fluid	filtered air with or without lubrication (in case lubrication is needed, it must be constant)
Working Temp	-5+50°C (23+122°F) Please note: Below 3°C the air of the circuit must be free from humidity
Max Valves Q.ty	20
Max. Pilot Q.ty	40
Voltage	24 V DC 310%
Potenza Singolo Pilota	1,3 W * see note
Configurazione Elettrica	PNP
Connessione Elettrica	multipole connector 25 pin (up to 10 valve positions) multipole connector 44 pin (from 2 to 20 valve positions)
Grado Di Protezione	IP40: standard multipole connection 25 pin IP65: multipole connection 25 and 44 pin

WORKING PRESSURE

Function	Pilot supply	Working pressure	Pilot pressure	flow rate Ø8mm (6=bar; dp=1bar)
5/2 monostable	internal - internal (1)	2 - 7 bar	(*)	900 NI/min
	esterno - external (12-14)	vuoto / vacuum - 10 bar	2 - 7 bar	
5/2 bistable	internal - internal (1)	1,5 - 7 bar	(*)	900 NI/min
	esterno - external (12-14)	vuoto / vacuum - 10 bar	1,5 - 7 bar	
5/3	internal - internal (1)	2,5 - 7 bar	(*)	800 NI/min
	esterno - external (12-14)	vuoto / vacuum - 10 bar	2,5 - 7 bar	
3/2 + 3/2	internal - internal (1)	3,5 - 7 bar	(*)	700-800 NI/min
	esterno - external (12-14)	vuoto / vacuum - 10 bar	3,5 - 7 bar	

(*) pilot supply pressure max: 7bar. An higher pressure may cause malfunctioning of the valve

VALVE ISLAND DIMENSIONS

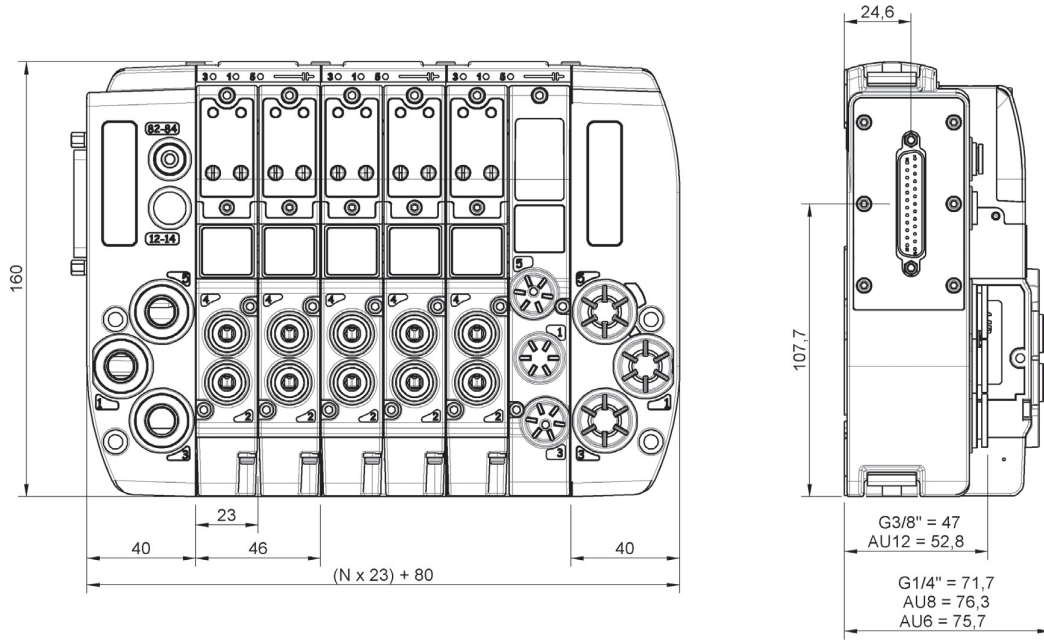

N = NUMERO TOTALE DI POSIZIONI
N = TOTAL POSITIONS NUMBER

LAYOUT

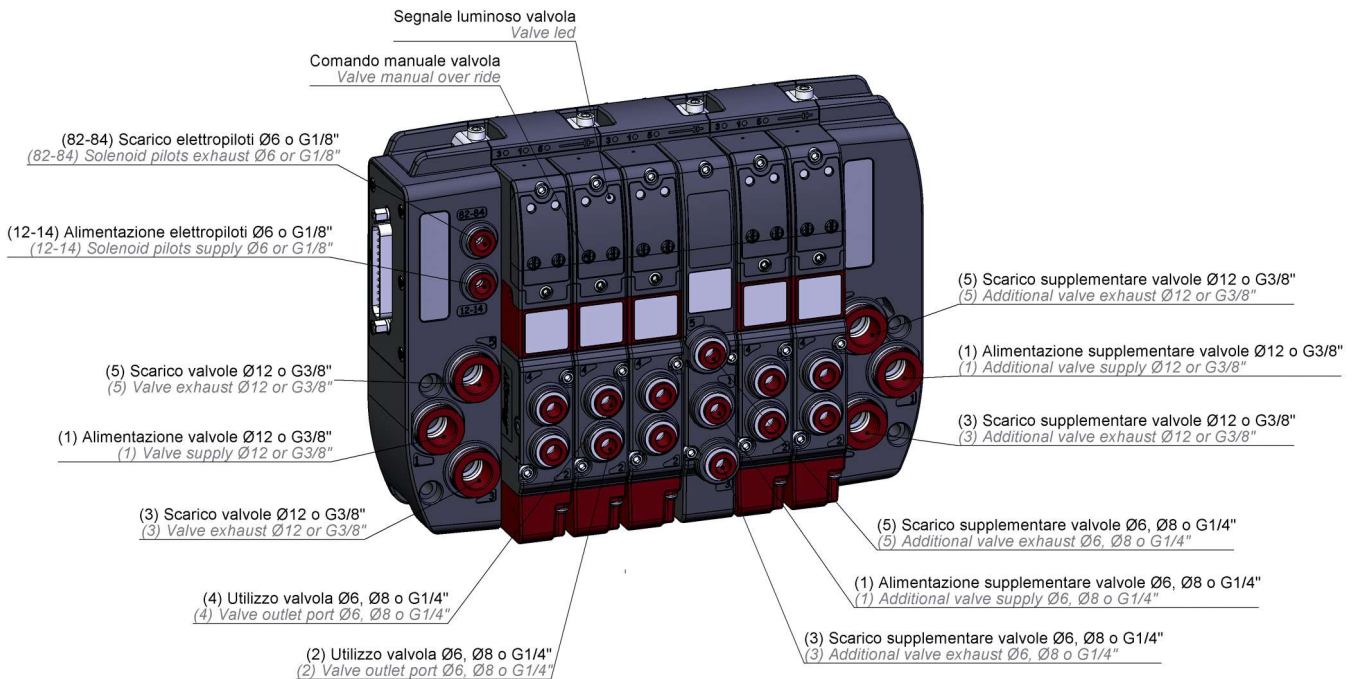

LINE 150 | MULTIPOLE VALVES

VALVE ISLAND CONFIGURATION

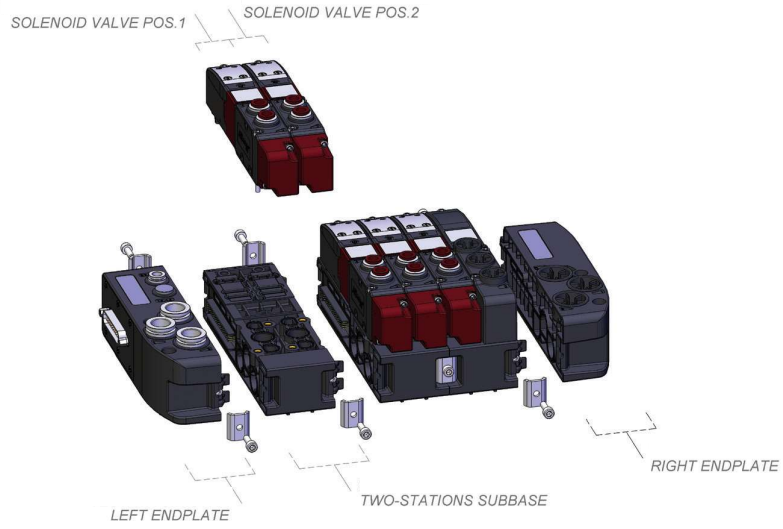

SUBBASES AND END PLATES ASSEMBLY

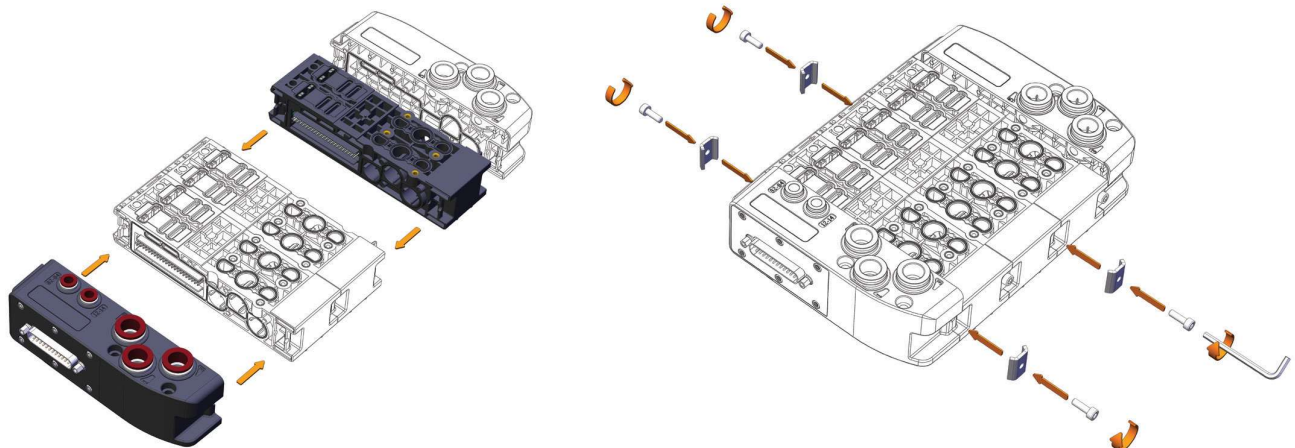

SOLENOID VALVES ASSEMBLY

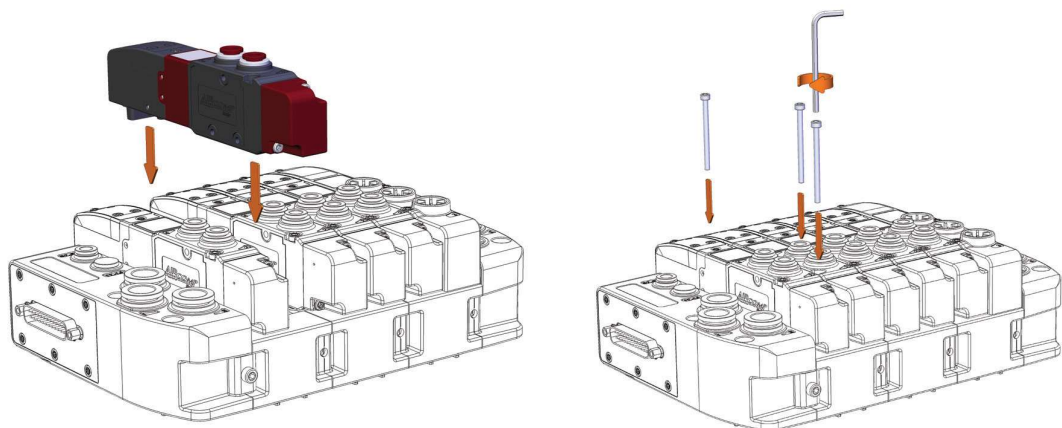

AIR PREPARATION

VALVES

CYLINDERS

FITTINGS

WATER PREPARATION

LINE 150 | MULTIPOLE VALVES

LEFT END PLATE

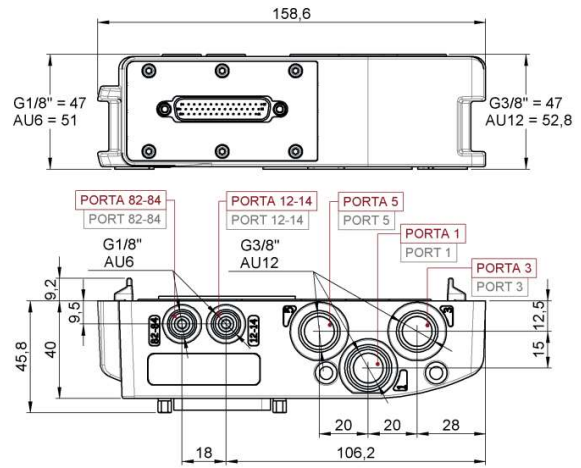

CODE	REFERENCE	CONNECTION PORT 1,3 AND 5	CONNECTION PORT 12-14/82-84	PILOT AIR SUP- PLY	OPERATING PRESSURE	PILOT PRESSURE
1501C00123	Sub-D 25 pins	G3/8"	G1/8"	Internal/External (for information see page 2.73)	Vacuum + 10[bar]	See Valves
1501C00124	Sub-D 44 pins	G3/8"	G1/8"			
1501C00125	Sub-D 25 pins	Push-in Ø12	Push-in Ø6			
1501C00126	Sub-D 44 pins	Push-in Ø12	Push-in Ø6			

AIR PREPARATION

VALVES

CYLINDERS

FITTINGS

WATER PREPARATION

LINE 150 | MULTIPOLE VALVES

AIR PREPARATION

VALVES

CYLINDERS

FITTINGS

WATER PREPARATION

RIGHT END PLATE

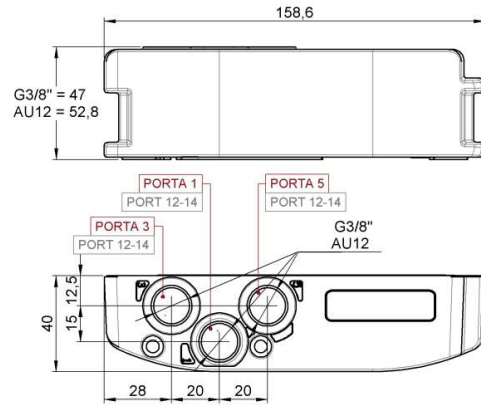

CODE	CONNECTION PORT 1,3 AND 5	PILOT AIR SUPPLY	OPERATING PRESSURE
1501C00127	Closed	Internal/External (for information see page 2.73)	Vacuum ± 10[bar]
1501C00128	G3/8"		
1501C00129	Push-in Ø12		

MODULAR SUBBASE

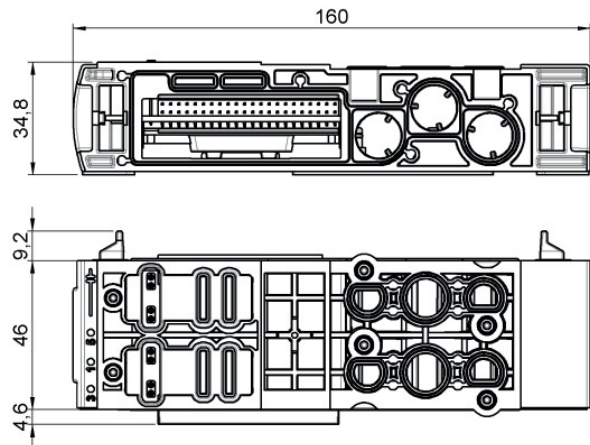

CODE	VALVE POSITION NUMBER	ELECTRIC SIGNAL FOR VALVE POSITION	OPERATING PRESSURE
1501C00130	2	2	Vacuum ± 10[bar]

LINE 150 | MULTIPOLE VALVES

VA 5/2 MONOSTABLE VALVES

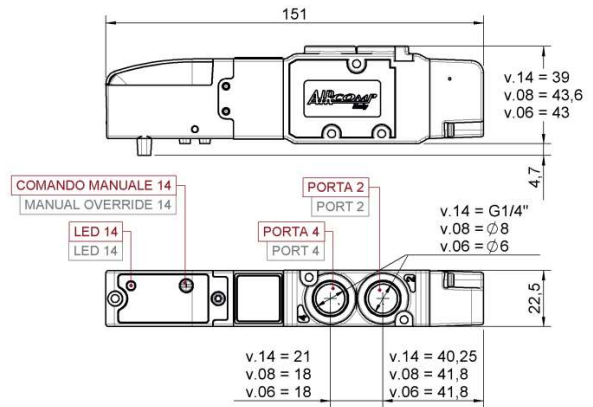

CODE	REFERENCE	CONNECTION PORT 2 - 4	SYMBOL	OPERATING PRESSURE	OPERATING PRESSURE	FLOW RATE AT 6[BAR] P=1
1501C00001	VA14	G1/4"		Vacuum ÷ 10[bar]	2÷7[bar]	900 NI/min (1/4")
1501C00002	VA08	Push-in Ø8				
1501C00003	VA06	Push-in Ø6				

VB 5/2 BISTABLE VALVES

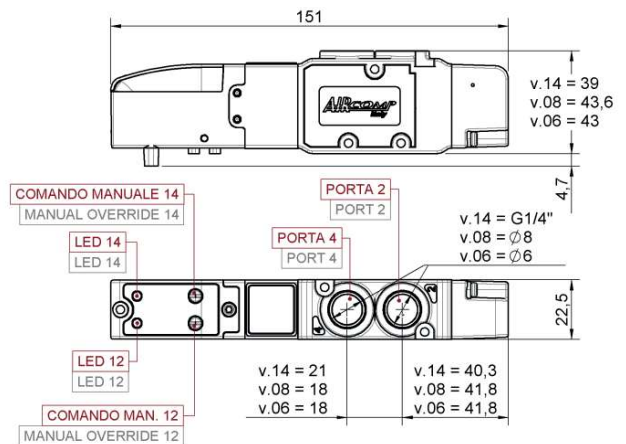

CODE	REFERENCE	CONNECTION PORT 2 - 4	SYMBOL	OPERATING PRESSURE	OPERATING PRESSURE	FLOW RATE AT 6[BAR] P=1
1501C00004	VB14	G1/4"		Vacuum ÷ 10[bar]	2÷7[bar]	900 NI/min (1/4")
1501C00005	VB08	Push-in Ø8				
1501C00006	VB06	Push-in Ø6				

AIR PREPARATION

VALVES

CYLINDERS

FITTINGS

WATER PREPARATION

LINE 150 | MULTIPOLE VALVES

AIR PREPARATION

VALVES

VC 5/3 CENTRE CLOSED VALVES

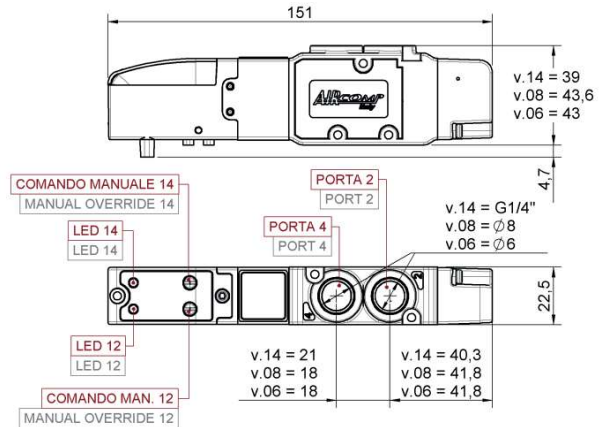

CODE	REFERENCE	CONNECTION PORT 2 - 4	SYMBOL	OPERATING PRESSURE	PILOT PRESSURE	FLOW RATE AT 6[BAR] $\Delta P=1$
1501C00007	VC14	G1/4"		Vacuum ÷ 10[bar]	2,5÷7[bar]	800 NI/min (1/4")
1501C00008	VC08	Push-in Ø8				
1501C00009	VC06	Push-in Ø6				

CYLINDERS

FITTINGS

VD 3/2 NC + 3/2 NO VALVES

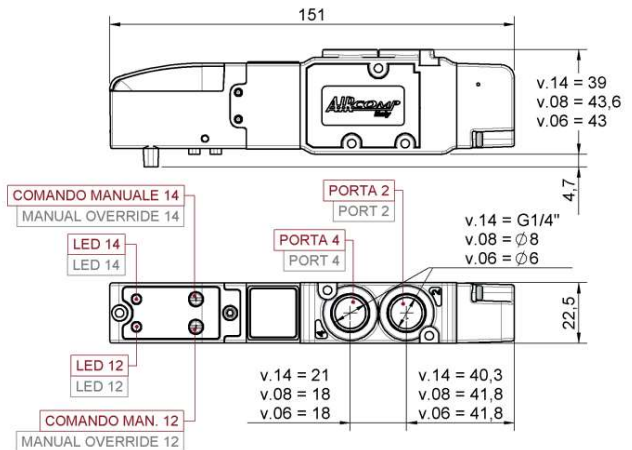

CODE	REFERENCE	CONNECTION PORT 2 - 4	SYMBOL	OPERATING PRESSURE	PILOT PRESSURE	FLOW RATE AT 6[BAR] $\Delta P=1$
1501C00010	VD14	G1/4"		Vacuum ÷ 10[bar]	3,5÷7[bar]	750 NI/min (1/4")
1501C00011	VD08	Push-in Ø8				
1501C00012	VD06	Push-in Ø6				

WATER PREPARATION

LINE 150 | MULTIPOLE VALVES

VE 3/2 NC + 3/2 NC (5/3 CA) VALVES

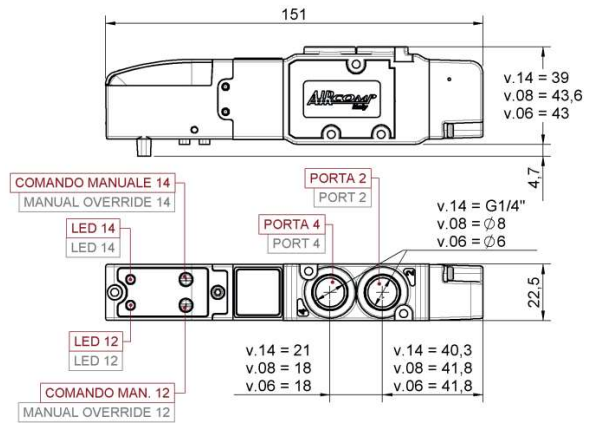

AIR PREPARATION

VALVES

CYLINDERS

FITTINGS

WATER PREPARATION

CODE	REFERENCE	CONNECTION PORT 2 - 4	SYMBOL	OPERATING PRESSURE	PILOT PRESSURE	FLOW RATE AT 6[BAR] ΔP=1
1501C00013	VE14	G1/4"		Vacuum ÷ 10[bar]	3,5÷7[bar]	800 NI/min (1/4")
1501C00014	VE08	Push-in Ø8				
1501C00015	VE06	Push-in Ø6				

VF 3/2 NO + 3/2 NO (5/3 CP) VALVES

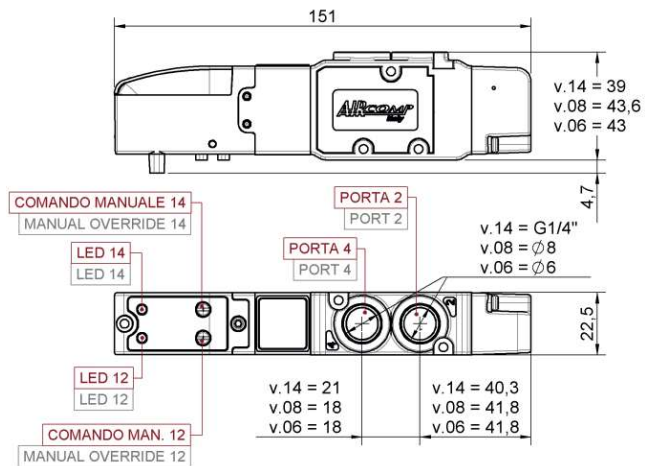

CODE	REFERENCE	CONNECTION PORT 2 - 4	SYMBOL	OPERATING PRESSURE	PILOT PRESSURE	FLOW RATE AT 6[BAR] ΔP=1
1501C00016	VF14	G1/4"		Vacuum ÷ 10[bar]	3,5÷7[bar]	700 NI/min (1/4")
1501C00017	VF08	Push-in Ø8				
1501C00018	VF06	Push-in Ø6				

LINE 150 | MULTIPOLE VALVES



AIR PREPARATION

VALVES

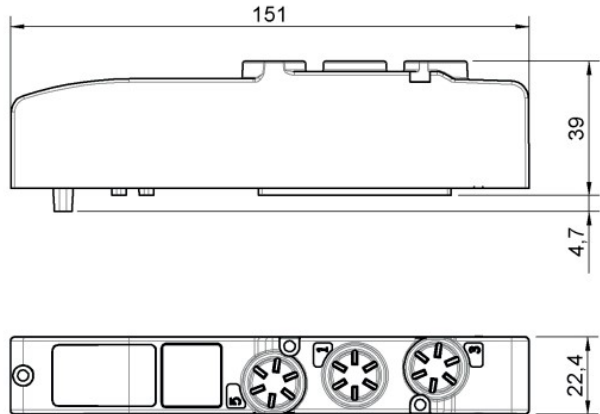
BLANKING PLATE



CYLINDERS



CODE	REFERENCE	SYMBOL	OPERATING PRESSURE
1501C00025	MS	  	Vacuum ÷ 10[bar]

FITTINGS

ADDITIONAL SUPPLY AND EXHAUST MODULE

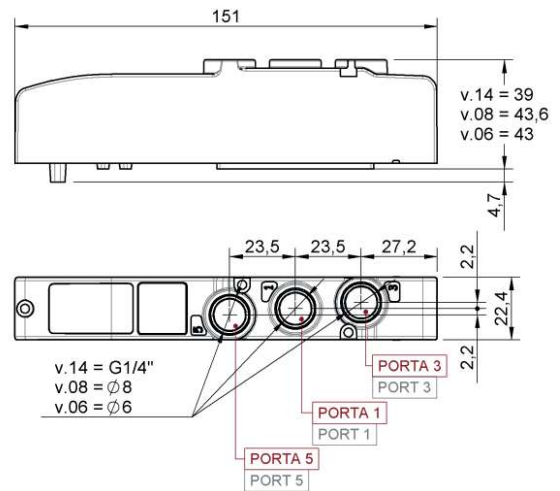
WATER PREPARATION



CODE	REFERENCE	CONNECTION PORT 1, 3 E 5	SYMBOL	OPERATING PRESSURE
1501C00026	MR14	G1/4" G1/4"		Vacuum ÷ 10[bar]
1501C00027	MR08	Push-in Ø8		
1501C00028	MR06	Push-in Ø6		

LINE 150 | MULTIPOLE VALVES

ACCESSORIES

PE SILENCERS

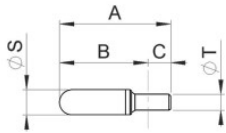

CODE	ØT	A	B	C	ØS
1601A00064	6	45	28,5	16,5	12,5
1601A00065	8	43	23,5	19,5	13,5
1601A00066	12	80	58	22	18,5

BRASS SILENCERS

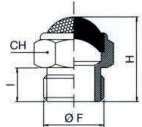

CODE	ØT	H	CH
391.01.18	G1/8"	15	13
391.01.14	G1/4"	18	16
391.01.38	G3/8"	20	19

DIN RAIL EN 60715 FIXING KIT



CODE	DESCRIPTION
1601C00018	DIN rail fixing kit

DIAPHRAGM PLUG



CODE	DESCRIPTION
1531C00010	Diaphragm plug

FIXING KIT - FEET



CODE	DESCRIPTION
1601C00017	Feet fixing kit

25 PIN IP40 CONNECTOR WITH CABLE



CODE	PIN	IP	LENGTH
1601C00002	25	40	3mt
1601C00003	25	40	5mt
1601C00004	25	40	10mt

25 PIN IP65 CONNECTOR WITH CABLE



CODE	PIN	IP	LENGTH
1601C00006	25	65	3mt
1601C00007	25	65	5mt
1601C00008	25	65	10mt

44 PIN IP65 CONNECTOR WITH CABLE



CODE	PIN	IP	LENGTH
1601C00014	44	65	3mt
1601C00015	44	65	5mt
1601C00016	44	65	10mt

AIR PREPARATION

VALVES

CYLINDERS

FITTINGS

WATER PREPARATION

LINE 150 | MULTIPOLE VALVES

AIR PREPARATION

VALVES

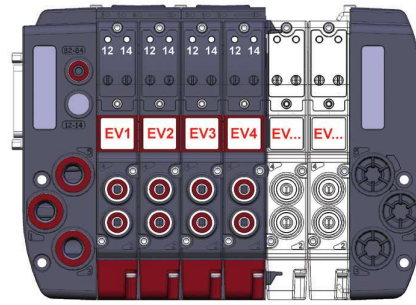

CYLINDERS

FITTINGS

WATER PREPARATION

SUB-D 25 PIN CONNECTOR WIRING SCHEME

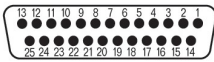

N° PIN	WIRE COLOUR	VALVE	PILOT
1	White	EV1	14
2	Brown	EV1	12
3	Green	EV2	14
4	Yellow	EV2	12
5	Grey	EV3	14
6	Pink	EV3	12
7	Blue	EV4	14
8	Red	EV4	12
9	Black	EV5	14
10	Purple	EV5	12
11	Grey	EV6	14
12	Red/Blue	EV6	12
13	White/Green	EV7	14
14	Brown/Green	EV7	12
15	White/Yellow	EV8	14
16	Yellow/Brown	EV8	12
17	White/Grey	EV9	14
18	Grey/Brown	EV9	12
19	White/Pink	EV10	14
20	Pink/Brown	EV10	12
21	White/Blue	common	14
22	Brown/Blue	common	12
23	White/Red	common	14
24	Brown/Red	common	12
25	White/Black	common	14

SUB-D 44 PIN CONNECTOR WIRING SCHEME



N° PIN	WIRE COLOUR	VALVE	PILOT
1	White	EV1	14
2	Brown	EV1	12
3	Green	EV2	14
4	Yellow	EV2	12
5	Grey	EV3	14
6	Pink	EV3	12
7	Blue	EV4	14
8	Red	EV4	12
9	Black	EV5	14
10	Purple	EV5	12
11	Grey/Pink	EV6	14
12	Red/Blue	EV6	12
13	White/Green	EV7	14
14	Brown/Green	EV7	12
15	White/Yellow	EV8	14
16	Yellow/Brown	EV8	12
17	White/Grey	EV9	14
18	Grey/Brown	EV9	12
19	White/Pink	EV10	14
20	Pink/Brown	EV10	12
21	White/Blue	EV11	14
22	Brown/Blue	EV11	12
23	White/Red	EV12	14
24	Brown/Red	EV12	12
25	White/Black	EV13	14
26	Brown/Black	EV13	12
27	Grey/Green	EV14	14
28	Yellow/Grey	EV14	12
29	Pink/Green	EV15	14
30	Yellow/Pink	EV15	12
31	Green/Blue	EV16	14
32	Yellow/Blue	EV16	12
33	Green/Red	EV17	14
34	Yellow/Red	EV17	12
35	Green/Black	EV18	14
36	Yellow/Black	EV18	12
37	Grey/Blue	EV19	14
38	Pink/Blue	EV19	12
39	Grey/Red	EV20	14
40	Pink/Red	EV20	12
41	Grey/Black	common	14
42	Pink/Black	common	12
43	Blue/Black	common	14
44	Red/Black	common	12

CONVERTING LEFT END PLATE FROM INTERNAL PILOT AIR SUPPLY TO EXTERNAL PILOT AIR SUPPLY

LEFT end plate, that is supplied separately, is always preset for INTERNAL pilot air supply. In this case, the end plate is equipped with a plug on supply connection 12-14. This plug must be maintained if the valve island you need to assemble requires internal air supply, whereas exhaust of pilot 12-14 must remain open.

If you need the end plate to be with EXTERNAL air supply, do the following operations:

PHASE 1 - END PLATE AU12

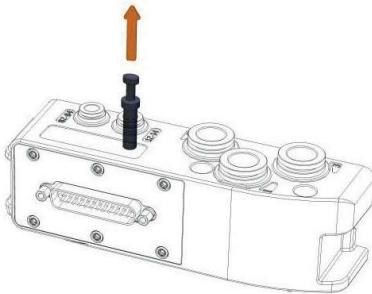

Phase 1. Remove plug from push-in fitting on connection 12-14

PHASE 2 - END PLATE AU12

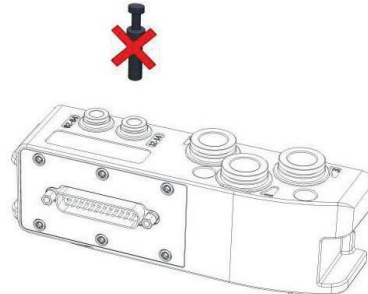

Phase 2. Scrap plug and connect supply pipe on connections 12-14

PHASE 1 - END PLATE CONNECTION 3/8

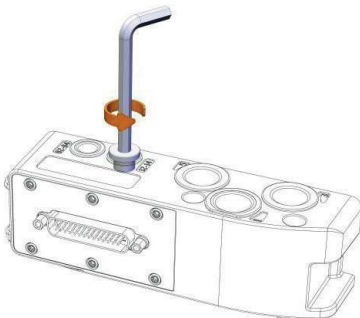

Phase 1. Unscrew the plug from connection 12-14

PHASE 1 - END PLATE CONNECTION 3/8LINE

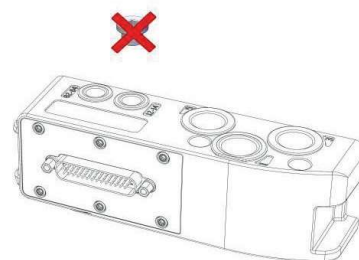

Phase 1. Scrap plug, mount fitting and connect supply pipe on connections 12-14.

ATTENTION: realizing a valve island with EXTERNAL pilot air supply requires converting both LEFT end plate and RIGHT end plate, as shown in following page.

LINE 150 | MULTIPOLE VALVES

AIR PREPARATION

VALVES

CYLINDERS

FITTINGS

WATER PREPARATION

CONVERTING RIGHT END PLATE FROM INTERNAL PILOT AIR SUPPLY TO EXTERNAL PILOT AIR SUPPLY

RIGHT end plate, that is supplied separately, is always preset for INTERNAL pilot air supply. In this case, the plate positioned on the back of end plate will bear the wording "pilots supply" turned towards 1.

If you need the end plate to be with EXTERNAL air supply, do the following operations:

PHASE 1

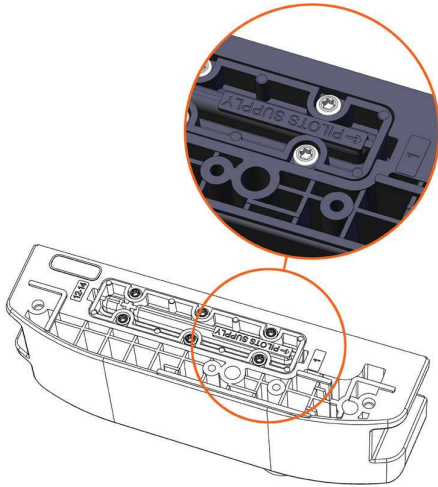

Phase 1. Position of plate for internal air supply

PHASE 2

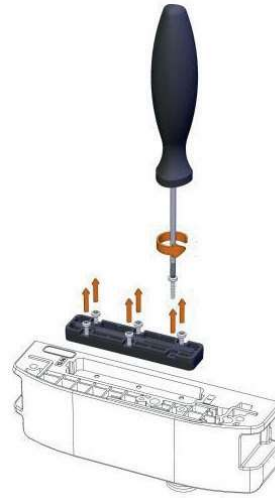

Phase 2. Unscrew the 6 fixing screws and lift the plate

PHASE 3

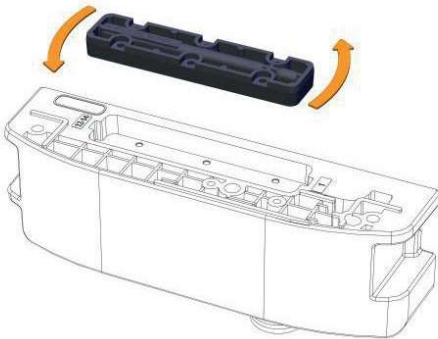

Phase 3. Turn the plate to 180° and re-assemble the 6 fixing screws

PHASE 4

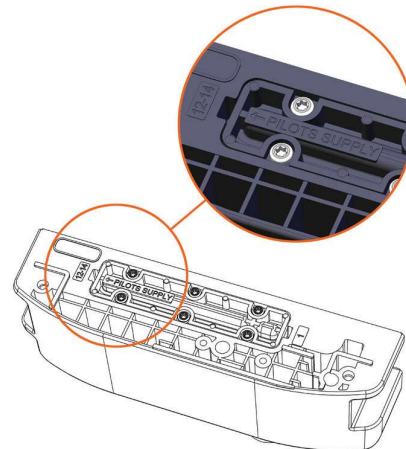

Phase 4. Check that the wording "pilots supply" is oriented towards 12-14

LINE 150 | GUIDE TO REFERENCES

GUIDE TO REFERENCES

SM150 6 025 B VA14 - VB14 - C001 - VB14 - VA14 - VE14 - MS

Product

SM150 = Valves Battery line 150

Total Positions Number

(from 2 to 20 max. positions)

6 = 6 positions

Electric connection

025 = SUB-D 25 pin (from 2 to 10 valve positions)

044 = SUB-D 44 pin (from 2 to 20 valve positions)

Pneumatic Supply Type

B = see CHART.1

Punits Position And Sequence (see CHART 2)

Pos.1 = VA14

Pos.2 = VB14

Pos.3 = VB14

Pos.4 = VA14

Pos.5 = VE14

Pos.6 = MS

Diaphragm Plug

C001 = Plug on port 1

C035 = Plug on port 3-5

C135 = Plug on port 1-3-5

CHART 1



PNEUMATIC SUPPLY: POSSIBLE CONFIGURATIONS

REFERENCE	LEFT END PLATE	RIGHT END PLATE	PILOTS AIR SUPPLY	LAYOUT
A	G3/8"	Closed	Internal	
B	G3/8"	G3/8"	Internal	
C	Push-in Ø12	Closed	Internal	
D	Push-in Ø12	Push-in Ø12	Internal	
E	G3/8"	Closed	External	
F	G3/8"	G3/8"	External	
G	Push-in Ø12	Closed	External	
H	Push-in Ø12	Push-in Ø12	External	

CHART 2



VALVES AND MODULES

REF.	FUNCTION	CONNECTION	SYMBOL
VA14	5/2 monostable	G1/4"	
VA08	5/2 monostable	Push-in Ø8	
VA06	5/2 monostable	Push-in Ø6	
VB14	5/2 bistable	G1/4"	
VB08	5/2 bistable	Push-in Ø8	
VB06	5/2 bistable	Push-in Ø6	
VC14	5/3 CC	G1/4"	
VC08	5/3 CC	Push-in Ø8	
VC06	5/3 CC	Push-in Ø6	
VD14	3/2 NC + 3/2 NO	G1/4"	
VD08	3/2 NC + 3/2 NO	Push-in Ø8	
VD06	3/2 NC + 3/2 NO	Push-in Ø6	
VE14	3/2 NC + 3/2 NC (5/3 CA)	G1/4"	
VE08	3/2 NC + 3/2 NC (5/3 CA)	Push-in Ø8	
VE06	3/2 NC + 3/2 NC (5/3 CA)	Push-in Ø6	
VF14	3/2 NO + 3/2 NO (5/3 CP)	G1/4"	
VF08	3/2 NO + 3/2 NO (5/3 CP)	Push-in Ø8	
VF06	3/2 NO + 3/2 NO (5/3 CP)	Push-in Ø6	
MS	Vacant valve position		
MR	Additional supply module		

AIR PREPARATION

VALVES

CYLINDERS

FITTINGS

WATER PREPARATION

LINE 150 | MULTIPOLE VALVES

AIR PREPARATION

VALVES

VALVE ISLAND FIXING

FIXING WITH SCREWS M5

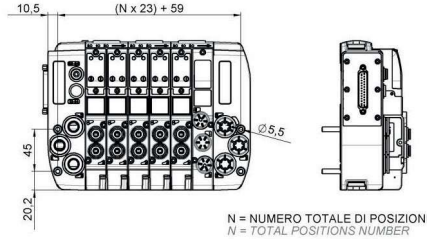

CYLINDERS

FIXING WITH FEET - POSITION 1

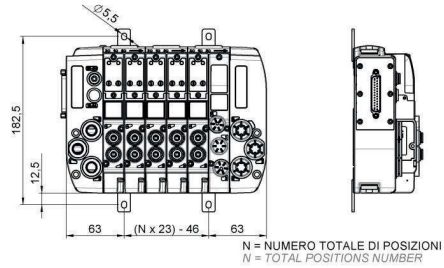

FITTINGS

FIXING WITH FEET - POSITION 2

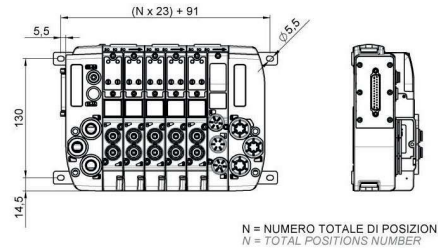

WATER PREPARATION

FIXING WITH DIN RAIL - POSITION 1

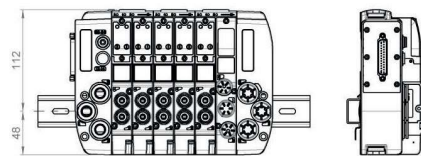

FIXING WITH DIN RAIL - POSITION 2

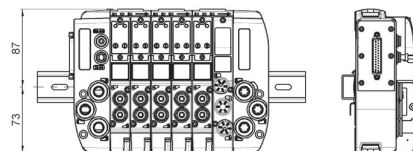

LINE 160 | MULTIPOLE VALVES

MP valve islands can be considered real integrated systems. Besides their remarkable flexibility in usage and outstanding performance, we have chosen to add a strong aesthetic feature, focusing on "design" during the planning phase.

The wide availability of modules having different configurations allows meeting any application requirement at best, while the integration of valves electrical cabling reduces drastically cabling times of the valve island.

The possibility of assembling up to 16 double solenoid valves enables the maximum streamlining of the pneumatic circuit in each system.

Finally, the great versatility of this product is confirmed even when assembling the complete valve island. In fact, you can choose between two different fixings methods: by means of DIN rail or through Feet.



AIR PREPARATION

VALVES

CYLINDERS

FITTINGS

WATER PREPARATION

GENERAL TECHNICAL DATA

Fluid	filtered air with or without lubrication (in case lubrication is needed, it must be constant)
Working Temp	-5+50°C (23+122°F) Please note: Below 3°C the air of the circuit must be free from humidity
Max Valves Q.ty	16
Max. Pilot q.Ty	32
Voltage	24 V DC 310%
Potenza Singolo Pilota	1 W * see note
Electrical Configuration	PNP
Electric Connection	multipole connector 25 pin (up to 10 valve positions) multipole connector 44 pin (from 11 to 16 valve positions)
Degree of protection	IP65: standard multipole connection 25 and 44 pin single cabling with connector and seal

WORKING PRESSURE

Function	Pilot supply	Operating pressure	Pilot operating pressure	Flow Rate Diam.8mm (6=Bar; Dp=1bar)
5/2 monostable	internal (1)	2,5 - 8 bar	(*)	1000 NI/min
	external (12-14)	vacuum - 10 bar	2,5 - 8 bar	
5/2 bistable	internal (1)	2,5 - 8 bar	(*)	1000 NI/min
	external (12-14)	vacuum - 10 bar	2,5 - 8 bar	
5/3	internal (1)	2,5 - 8 bar	(*)	850 NI/min
	external (12-14)	vacuum - 10 bar	2,5 - 8 bar	
3/2 + 3/2	internal (1)	3,2 - 8 bar	(*)	800 NI/min
	external (12-14)	vacuum - 10 bar	3,2 - 8 bar	
3/2	internal (1)	3,2 - 8 bar	(*)	800 NI/min
	external (12-14)	vuoto / vacuum - 10 bar	3,2 - 8 bar	

(*) Attention the pilot supply pressure max: 7bar. An higher pressure may cause malfunctioning of the valve

LINE MP 160 | GENERAL FEATURES

AIR PREPARATION

VALVES

CYLINDERS

FITTINGS

WATER PREPARATION

Multi-P valve islands have been developed for guaranteeing the utmost reliability over time.

For ensuring pneumatic tightness, even under particular stress, we have adopted an assembling system of traditional type, by means of screws.

For guaranteeing transmission of electrical signal, even in case of troubling vibrations, we made the choice of mounting just one electronic card of hard type.

The electrical control part (solenoid pilot) can be easily checked, also when the valve island is installed, simply disassembling the upper cover consisting of one integrated module only.

All setting and checking operations can be carried out from outside on the installed island. The manual override of each valve and Led for visual check are positioned within easy reach on the upper part of cover.

All pneumatic connections are complete with inbuilt push-in fitting and positioned on one side so as to make pipes mounting easier.

Then, the electrical connection of the system consists of a SUB-D 25 or 44 Pin connector, according to the valve island dimensions.

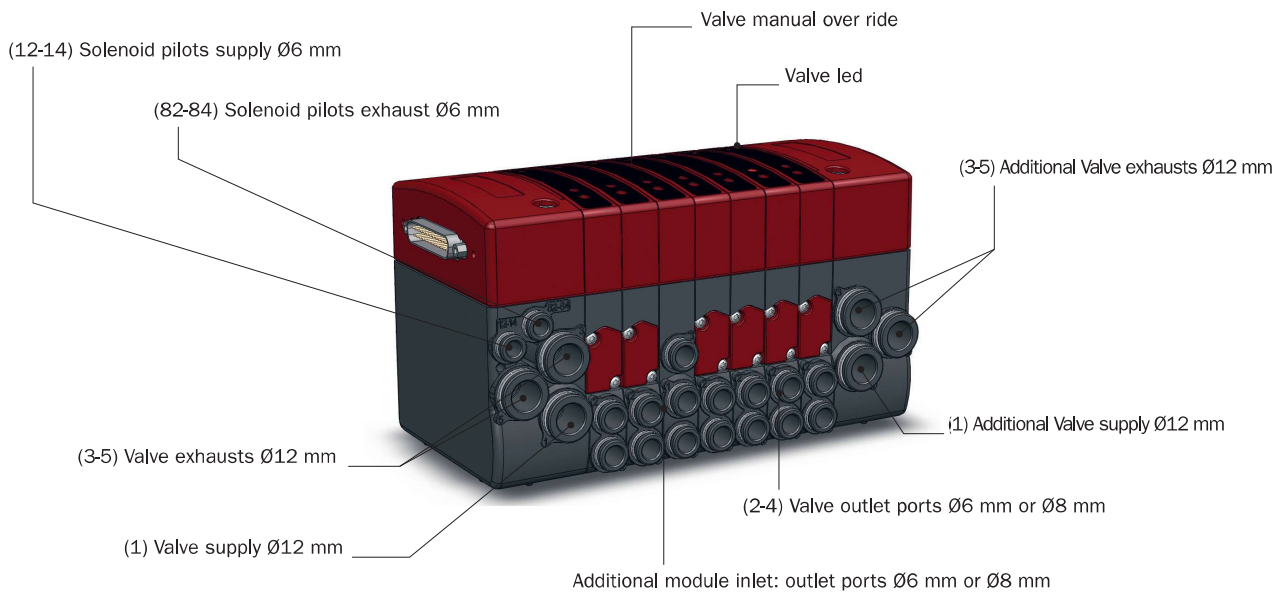
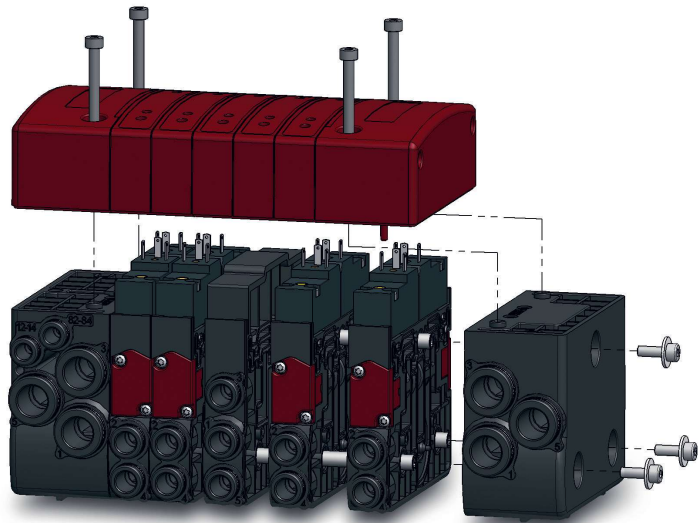

LINE MP 160 | DIMENSIONS

SINGLE CABLING WITH CONNECTOR DIMENSIONS

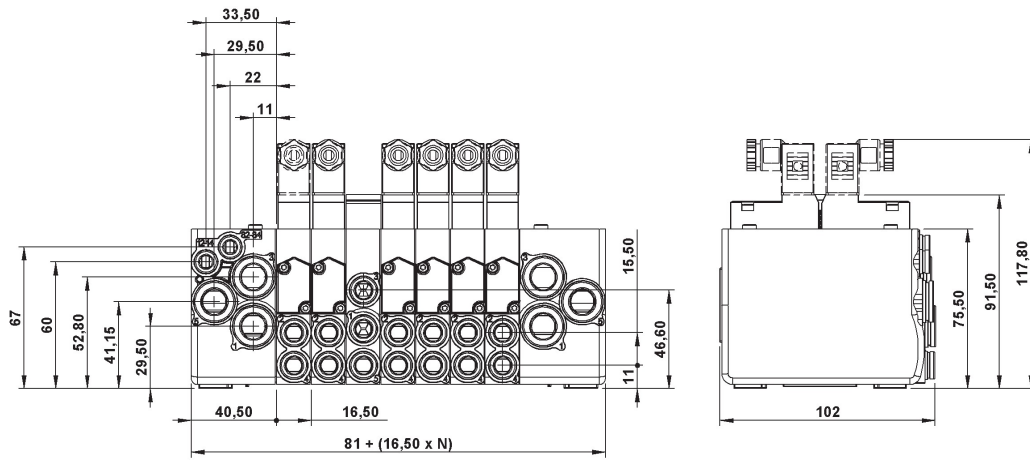

MULTIPOLE CABLING DIMENSIONS

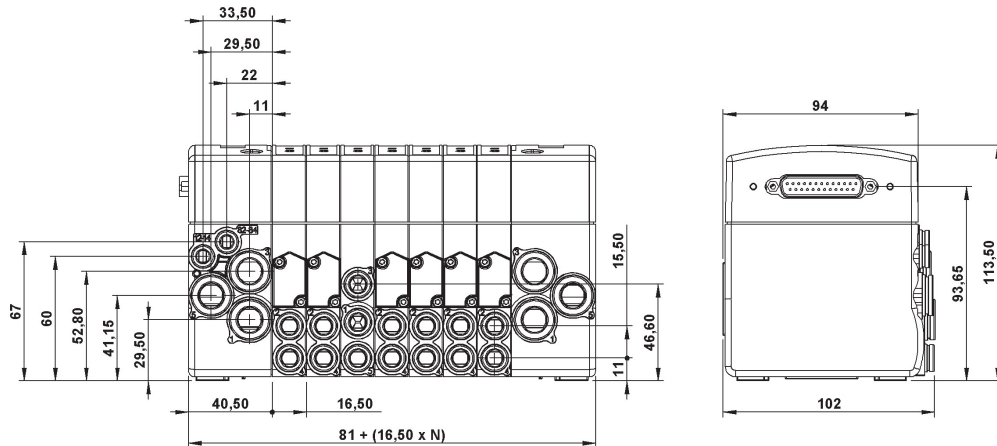

ASSEMBLING KIT DIMENSIONS

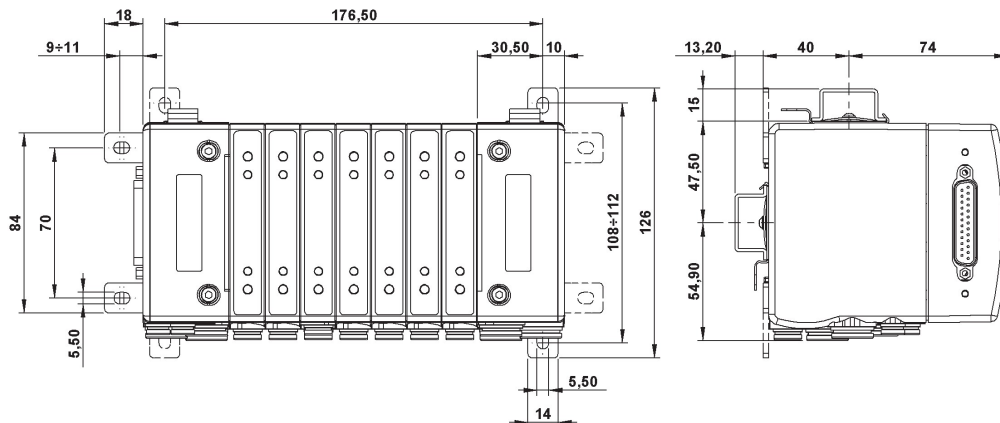

AIR PREPARATION

VALVES

CYLINDERS

FITTINGS

WATER PREPARATION

LINE MP 160 | BATTERY FIXING

AIR PREPARATION

VALVES

CYLINDERS

FITTINGS

WATER PREPARATION

FIXING BY MEANS OF DIN EN 60715 ON REAR

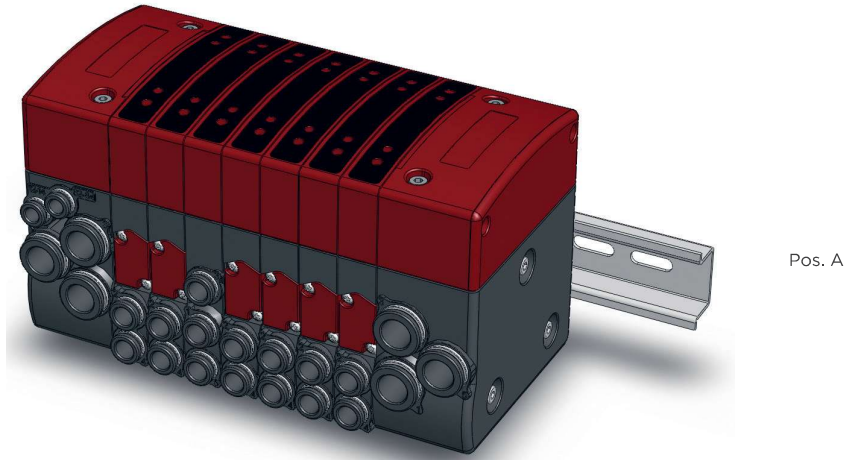

FIXING BY MEANS OF DIN EN 60715 RAIL ON BASE

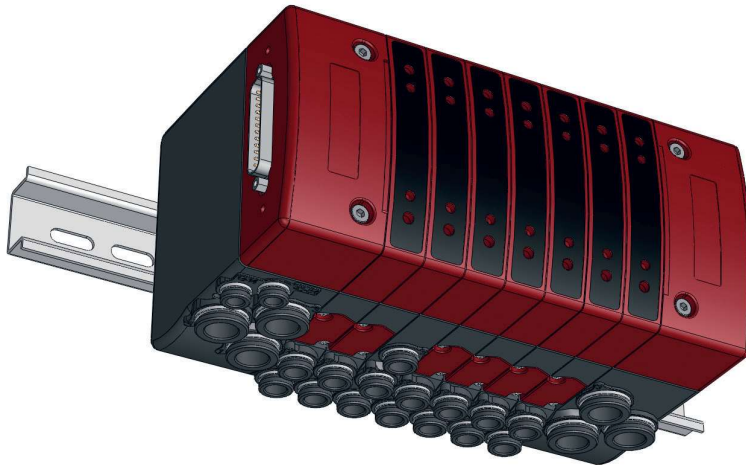

FIXING BY MEANS OF STRAIGHT OR SIDE FEET

Pos. 1

Pos. 2

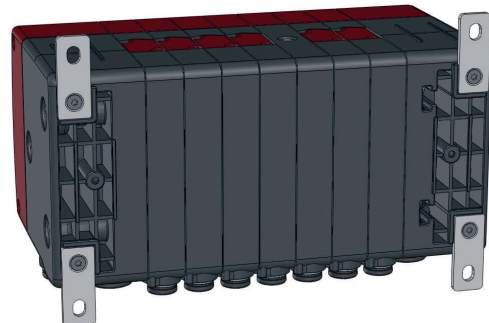
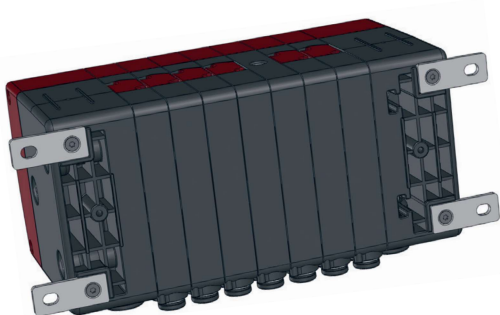

LINE MP 160 | BATTERY ARRANGEMENT

We made the choice of supplying the valve island already assembled according to Customer's specifications, with a view to ensure that any produced part undergoes the final pneumatic and electrical testing on the basis of set standard parameters.

The valve island configuration can be defined by means of the reference guide you find hereunder.

In fact, reference is the "explaining" key, summarizing the information

about the valve island at issue.

Description will be essential for asking information, calculating the price of the whole valve island and ordering it complete.

Then, an identification code will be attached to the complete island, through which it will be possible to re-order quickly and safely the product and allow any operator to identify clearly the configuration, at any time.

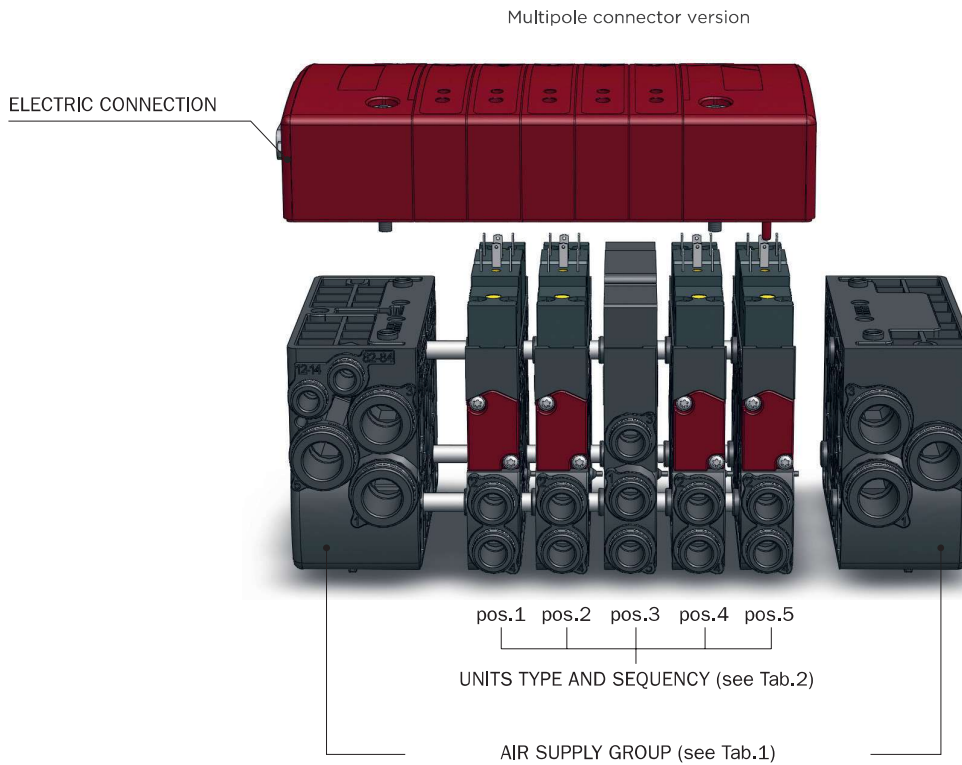

Single cabling with connector version



AIR PREPARATION

VALVES

CYLINDERS

FITTINGS

WATER PREPARATION

LINE MP 160 | BATTERY ARRANGEMENT

AIR PREPARATION

VALVES

GUIDE TO REFERENCES

MP160 5 025 B VA8-VB8-MZ8-VB8-VF6

Product MP160 = Valves Battery line 160	Units Position And Sequence (See Tab.2 And Tab.3) Pos.1 = VA8 Pos.2 = VB8 Pos.3 = MZ8 Pos.4 = VB8 Pos.5 = VF6
Total Positions Number (from 2 to 16 max. positions) 5 = 5 positions	Pneumatic Supply Type B = see Tab.1
Electric Connection 025 = SUB-D 25 pin (up to 10 valve positions) 044 = SUB-D 44 pin (from 11 to 16 valve positions) CON = connector individual wiring	

CYLINDERS

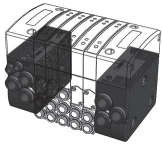

TAB. 1 - AIR SUPPLY: POSSIBLE CONFIGURATIONS

CONFIGURATION	DESCRIPTION	PILOT SUPPLY	PORTS 1, 3, 5	PORT 12-14	PORT 82-84	REFERENCE
	air supply in Left End Plate - Right End Plate closed internal pilot supply external pilot exhaust	from port (1)	Ø12 mm	closed	Ø6 mm	A
	air supply in both End Plates external pilot exhaust	from port (1)	Ø12 mm	closed	Ø6 mm	B
	Right End Plate closed external pilot supply external pilot supply	from port (12-14)	Ø12 mm	Ø6 mm	Ø6 mm	C
	air supply in both End Plates external pilot supply	from port (12-14)	Ø12 mm	Ø6 mm	Ø6 mm	D

FITTINGS

WATER PREPARATION

LINE MP 160 | BATTERY ARRANGEMENT

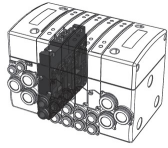

TAB. 2 - VALVES

FUNCTION	PILOT	RETURN	SYMBOL	PORTS	REFERENCE
5/2 monostable	solenoid	pneumatic spring		automatic Ø6 mm	VA6
				automatic Ø8 mm	VA8
5/2 bistable	solenoid	solenoid		automatic Ø6 mm	VB6
				automatic Ø8 mm	VB8
5/3 CC	solenoid	Spring		automatic Ø6 mm	VC6
				automatic Ø8 mm	VC8
3/2+3/2 NC+NO	solenoid	Spring		automatic Ø6 mm	VD6
				automatic Ø8 mm	VD8
3/2+3/2 NC+NC (5/3 CA)	solenoid	Spring		automatic Ø6 mm	VE6
				automatic Ø8 mm	VE8
3/2+3/2 NO+NO (5/3 CP)	solenoid	Spring		automatic Ø6 mm	VF6
				automatic Ø8 mm	VF8
3/2 NC	solenoid	Spring		automatic Ø6 mm	VG6
				automatic Ø8 mm	VG8
3/2 NO	solenoid	Spring		automatic Ø6 mm	VH6
				automatic Ø8 mm	VH8

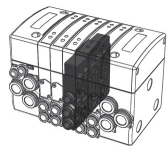

TAB. 3 - ADDITIONAL INTERMEDIATE UNITS

SYMBOL	DESCRIPTION	PORT 1	PORT 3	PORT 5	REFERENCE
	additional supply port to the right side open exhaust ports on the right closed supply and exhaust ports on the left	automatic Ø6 mm	automatic Ø6 mm	automatic Ø6 mm	MZ6
		automatic Ø8 mm	automatic Ø8 mm	automatic Ø8 mm	MZ8
	blanking plate	closed	closed	closed	MX
	spacing module (vacant valve position)	closed	closed	closed	MS
	additional supply module	automatic Ø6 mm	automatic Ø6 mm	automatic Ø6 mm	MR6
		automatic Ø8 mm	automatic Ø8 mm	automatic Ø8 mm	MR8

AIR PREPARATION

VALVES

CYLINDERS

FITTINGS

WATER PREPARATION

LINE MP 160 | ACCESSORIES

AIR PREPARATION

25 PIN IP 40 CONNECTOR WITH CABLE



CODE	PIN	IP	LENGTH
1601C00002	25	40	3 m
1601C00003	25	40	5 m
1601C00004	25	40	10 m

VALVES

25 PIN IP 65 CONNECTOR WITH CABLE



CODE	PIN	IP	LENGTH
1601C00006	25	65	3 m
1601C00007	25	65	5 m
1601C00008	25	65	10 m

CYLINDERS

44 PIN IP 65 CONNECTOR WITH CABLE



CODE	PIN	IP	LENGTH
1601C00014	44	65	3 m
1601C00015	44	65	5 m
1601C00016	44	65	10 m

FITTINGS

15MM 24V LED CONNECTOR



CODE	REF.
A502600020	15mm Led Connector 24V

WATER PREPARATION

15MM STANDARD CONNECTOR



CODE	REF.
A502600014	15mm Connector

15MM 24V CABLED LED CONNECTOR



CODE	LENGTH
A502600023	3 m

15MM PILOT VALVE



CODE	REF.
1601A00040	EV 3/2 NC 1W 24V DC

PE SILENCERS



CODE	ØT	A	B	ØS
1601A00064	6	45	28,5	12,5
1601A00065	8	43	23,5	13,5
1601A00066	12	80	58	18,5

FIXING KIT - FEET



CODE	REF.
1601C00017	Fixing Kit feet

FIXING KIT ON DIN 60715 RAIL



CODE	REF.
1601C00018	DIN rail fixing Kit

LINE MP 160 | WIRING SCHEME

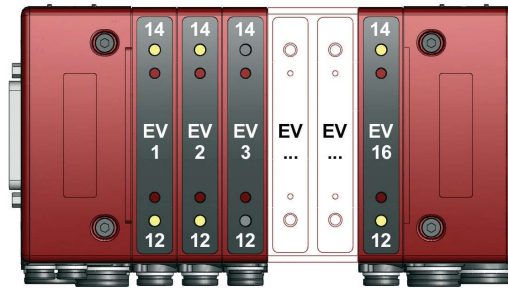

AIR PREPARATION

VALVES

CYLINDERS

FITTINGS

WATER PREPARATION

SUB-D 25 PIN CONNECTOR WIRING SCHEME

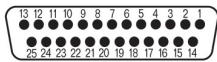

PIN N°	WIRE COLOUR	VALVE	PILOT
1	White	EV1	14
2	Brown	EV1	12
3	Green	EV2	14
4	Yellow	EV2	12
5	Grey	EV3	14
6	Pink	EV3	12
7	Blue	EV4	14
8	Red	EV4	12
9	Black	EV5	14
10	Purple	EV5	12
11	Grey	EV6	14
12	Red/Blue	EV6	12
13	White/Green	EV7	14
14	Brown/Green	EV7	12
15	White/Yellow	EV8	14
16	Yellow/Brown	EV8	12
17	White/Grey	EV9	14
18	Grey/Brown	EV9	12
19	White/Pink	EV10	14
20	Pink/Brown	EV10	12
21	White/Blue	common	14
22	Brown/Blue	common	12
23	White/Red	common	14
24	Brown/Red	common	12
25	White/Black	common	14

SUB-D 44 PIN CONNECTOR WIRING SCHEME

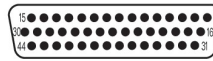

N° PIN	WIRE COLOUR	VALVE	PILOT
1	White	EV1	14
2	Brown	EV1	12
3	Green	EV2	14
4	Yellow	EV2	12
5	Grey	EV3	14
6	Pink	EV3	12
7	Blue	EV4	14
8	Red	EV4	12
9	Black	EV5	14
10	Purple	EV5	12
11	Grey/Pink	EV6	14
12	Red/Blue	EV6	12
13	White/Green	EV7	14
14	Brown/Green	EV7	12
15	White/Yellow	EV8	14
16	Yellow/Brown	EV8	12
17	White/Grey	EV9	14
18	Grey/Brown	EV9	12
19	White/Pink	EV10	14
20	Pink/Brown	EV10	12
21	White/Blue	EV11	14
22	Brown/Blue	EV11	12
23	White/Red	EV12	14
24	Brown/Red	EV12	12
25	White/Black	EV13	14
26	Brown/Black	EV13	12
27	Grey/Green	EV14	14
28	Yellow/Grey	EV14	12
29	Pink/Green	EV15	14
30	Yellow/Pink	EV15	12
31	Green/Blue	EV16	14
32	Yellow/Blue	EV16	12
33	Green/Red	common	
34	Yellow/Red	common	
35	Green/Black	common	
36	Yellow/Black	common	
37	Grey/Blue	common	
38	Pink/Blue	common	
39	Grey/Red	common	
40	Pink/Red	common	
41	Grey/Black	common	
42	Pink/Black	common	
43	Blue/Black	common	
44	Red/Black	common	

LINE 100-120-125-127 | VALVES FOR PANEL MOUNTING ACTUATORS

AIR PREPARATION

VALVES



CYLINDERS

GENERAL FEATURES

	line 100	line 120 125 127
Construction	poppet type	spool
Body material	technopolymer	technopolymer / aluminium
Single use	yes	yes
Combined use	yes	no
Available functions	2/2 - 3/2	3/2 - 5/2
Installation	through-wall panel actuator	

POSSIBLE COMBINATIONS EXAMPLE



FITTINGS

GENERAL TECHNICAL DATA

	line 100	line 120 125 127
Fluid	air	air
Connections	M5 - AU4	1/8 - 1/4
Temperature Range	-5 / +50°C (23 / 122°F) Please note: Below 3°C the air of the circuit must be free from humidity	
Working Pressure	2 - 10 bar	1 - 10 bar
Reference Pressure	75 l/min	670; 800; 800 l/min

WATER PREPARATION

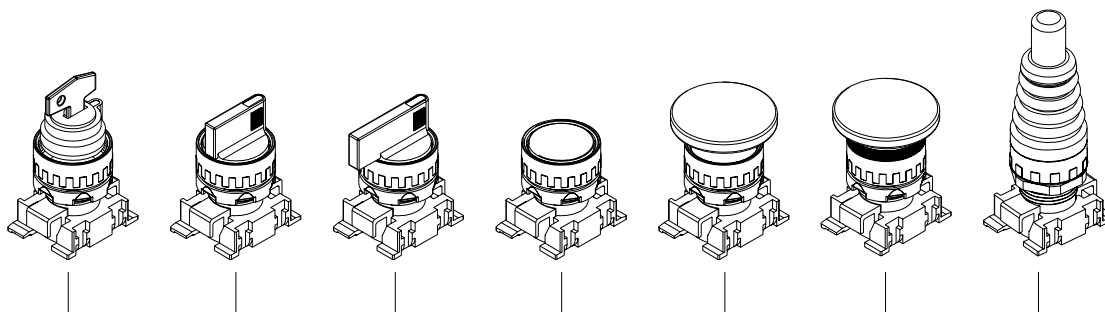

DRILLING MEASURES

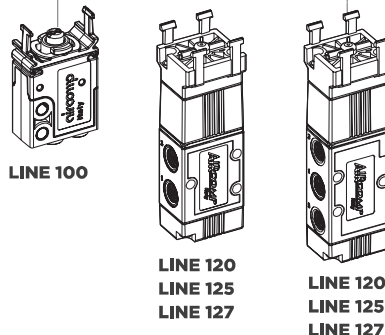
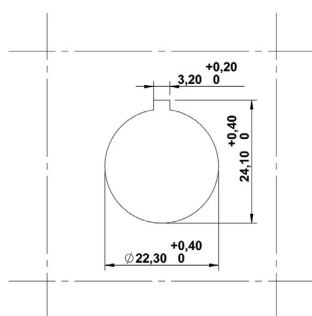

LINE 100-120-125-127 | PANEL ACTUATORS

AIR PREPARATION

VALVES

CYLINDERS

FITTINGS

WATER PREPARATION

PROTECTED PUSH BOTTON

Technopolymer body, round front element

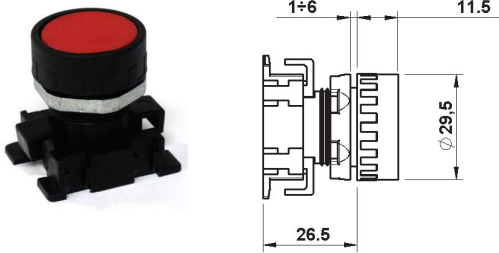

COLOR	CODE	REF.
RED	1003A00074	RT010 PULSANTE + COVER
BLACK	1003A00075	RT010 PULSANTE + COVER
YELLOW	1003A00076	RT010 PULSANTE + COVER
GREEN	1003A00077	RT010 PULSANTE + COVER
WHITE	1003A00078	RT010 PULSANTE + COVER
BLUE	1003A00079	RT010 PULSANTE + COVER

2 - 3 POSITIONS SHORT LEVER SELECTOR

Technopolymer body, round front element.

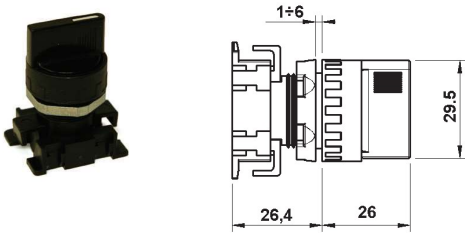

POSITION	CODE	REF.
	1003A00032	RT300N SELECTOR (2 FIXED POSITIONS)
	1003A00033	RT350N SELECTOR (2 RETURN POSITION)
	1003A00034	RT313N SELECTOR (3 FIXED POSITIONS)
	1003A00035	RT383N SELECTOR (3 RETURN TO CENTRE POSITION)

2 - 3 POSITIONS LONG LEVER SELECTOR

Technopolymer body, round front element.

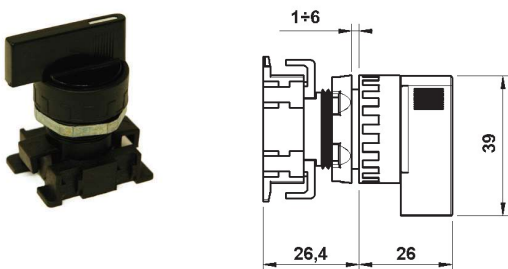

POSITION	CODE	REF.
	1003A00036	RT400N SELECTOR (2 FIXED POSITIONS)
	1003A00037	RT450N SELECTOR (2 RETURN POSITION)
	1003A00038	RT413N SELECTOR (3 FIXED POSITIONS)
	1003A00039	RT483N SELECTOR (3 RETURN TO CENTRE POSITION)

2 POSITIONS KEY SELECTOR

Technopolymer body, round front element

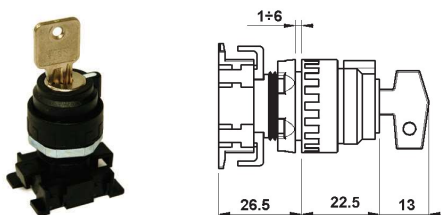

POSITION	CODE	REF.
	1003A00031	RT201N SELECTOR (2 FIXED POSITIONS)

LINE 100-120-125-127 | PANEL ACTUATORS

AIR PREPARATION

VALVES

AXIAL MUSHROOM

Technopolymer body, round front element.

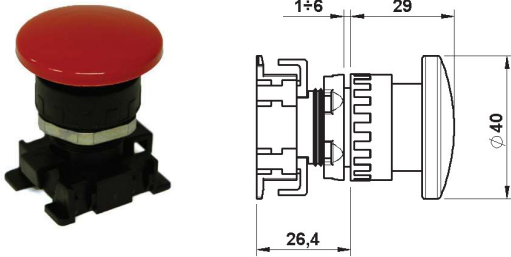

COLOR	CODE	REF.
RED	1003A00041	RT050R MUSHROOM
BLACK	1003A00042	RT050N MUSHROOM

CYLINDERS

FITTINGS

AXIAL MUSHROOM WITH TURN RESET

Technopolymer body, round front element.

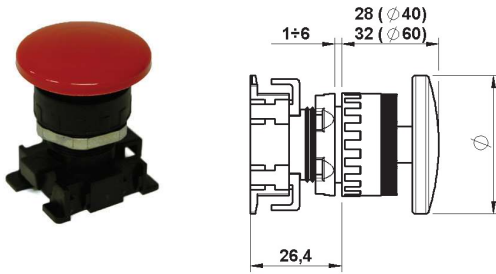

COLOR	CODE	REF.
RED	1003A00052	RT065R - 40 MUSHROOM (DIAM. 40mm)
RED	1003A00057	RT065R - 60 MUSHROOM (DIAM. 60mm)

WATER PREPARATION

3 POSITIONS LEVER

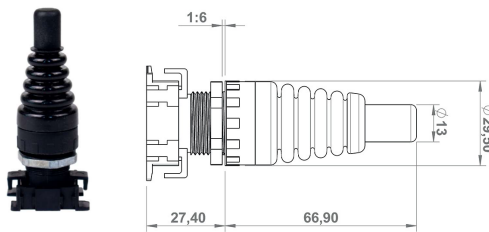

TYPE	CODE	Function
3 POSITIONS FIXED	1003A00084	
3 POSITIONS RETURN	1003A00085	

ELECTRICAL SWITCH*

For panel actuator.

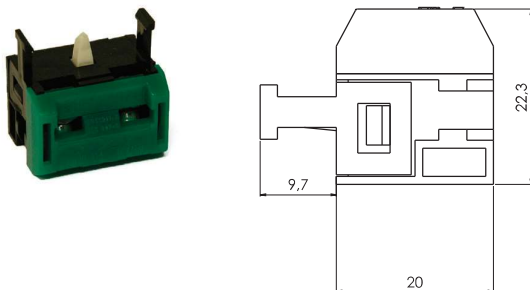

TECHNICAL DATA

Isolation Voltage	Vi 660
Termichal Current	Ith 12A
Protection	IP 20
Category of use	AC 15

COLOR	CODE	REF.
RED	1003A00050	CONTATTO NC
GREEN	1003A00051	CONTATTO NO

* Suitable for line 100 only.

LINE 100 M5-Ø4 | VALVES FOR PANEL MOUNTING ACTUATORS

MICROVALVES FOR PANEL MOUNTING ACTUATORS REAR PORTS

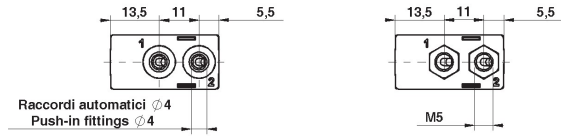

	CODE	REFERENCES
	1000412005 1000492005	MV M5 15 2 PB ML NC P MV AU4 15 2 PB ML NC P
	1000413009 1000493009	MV M5 15 3 PB ML NC P MV AU4 15 3 PB ML NC P
	1000413010 1000493010	MV M5 15 3 PB ML NO P MV AU4 15 3 PB ML NO P

TECHNICAL DATA

Weight 0,030 kg

NB: Possible combinations
5/2 = 3/2 NC + 3/2 NO
5/3 Open center = 3/2 NC + 3/2 NC

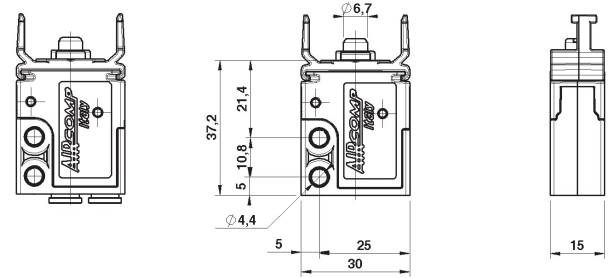

AU4 VERSION

M5 VERSION

POSSIBLE COMBINATIONS



For pannel actuators see Page 2.87

MICROVALVES FOR PANEL MOUNTING ACTUATORS WITH SIDE PORTS



	CODE	REFERENCES
	1000412105 1000492105	MV ML5 15 2 PB ML NC P MV AL4 15 2 PB ML NC P
	1000413109 1000493109	MV ML5 15 3 PB ML NC P MV AL4 15 3 PB ML NC P
	1000413110 1000493110	MV ML5 15 3 PB ML NO P MV AL4 15 3 PB ML NO P

TECHNICAL DATA

Weight 0,030 kg

NB: Possible combinations
5/2 = 3/2 NC + 3/2 NO
5/3 Open center = 3/2 NC + 3/2 NC

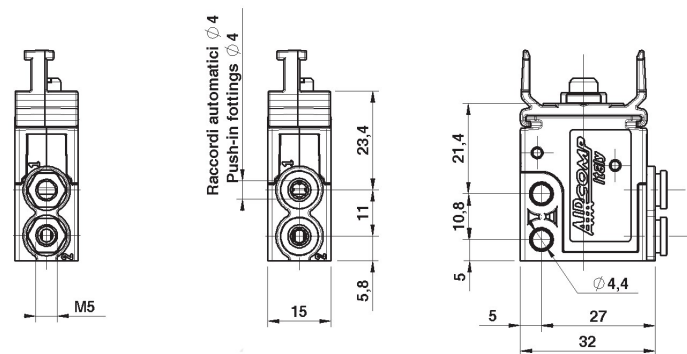

AU4 VERSION

M5 VERSION

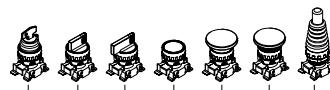

For pannel actuators see Page 2.87

AIR PREPARATION

VALVES

CYLINDERS

FITTINGS

WATER PREPARATION

LINE 120-1/8" VALVES FOR PANEL MOUNTING ACTUATORS

AIR PREPARATION

VALVES

3/2 VALVES FOR PANEL MOUNTING ACTUATORS



	CODE	REFERENCES
	1202523009	ME 1/8" 22 3 PB PM NC P
	1202523010	ME 1/8" 22 3 PB PM NO P

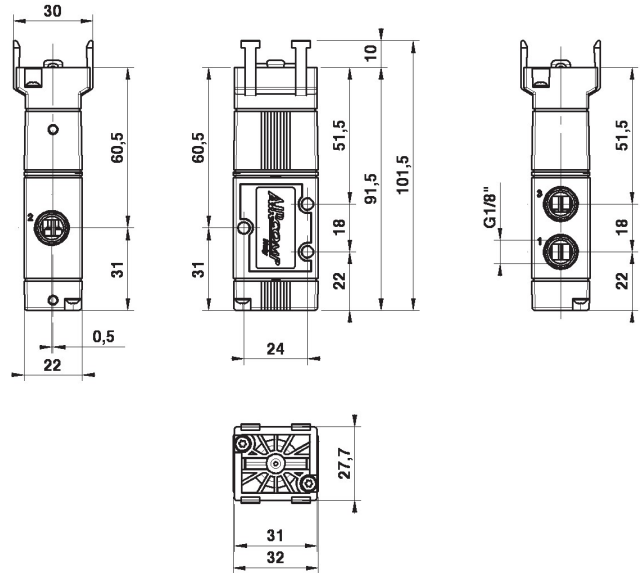

CYLINDERS

TECHNICAL DATA	
Working pressure	1±10 Bar (0,1±1,00 MPa)
Weight	0,078 kg

AVAILABLE CONFIGURATIONS (*)

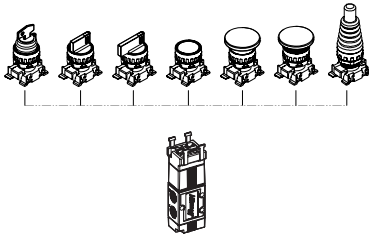

For actuators code and features, refer to page 2.87

FITTINGS

WATER PREPARATION

5/2 VALVES FOR PANEL MOUNTING ACTUATORS



	CODE	REFERENCES
	1202525005	ME 1/8" 22 5 PB PM OO P

TECHNICAL DATA	
Working pressure	1±10 Bar (0,01±1,00 MPa)
Weight	0,085 kg

AVAILABLE CONFIGURATIONS (*)

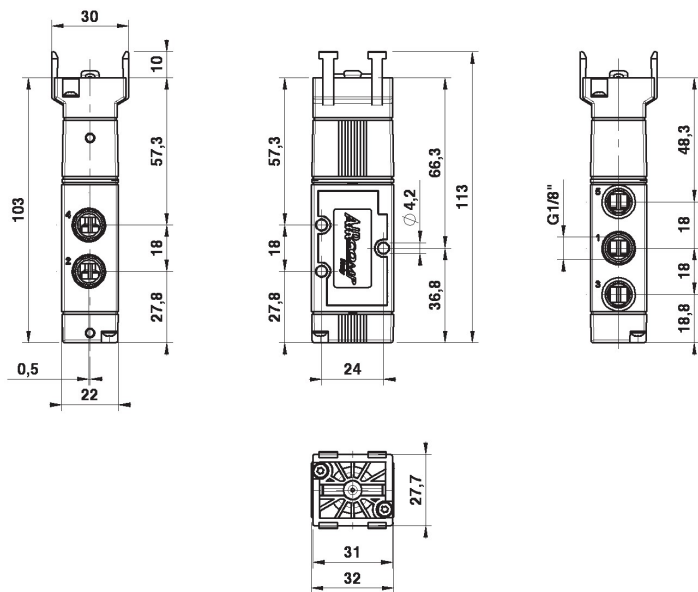
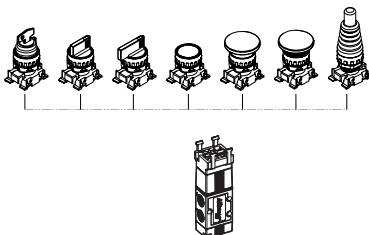

For actuators code and features, refer to page 2.87

LINE 125-1/4" | VALVES FOR PANEL MOUNTING ACTUATORS

3/2 VALVES FOR PANEL MOUNTING ACTUATORS



	CODE	REFERENCES
	1252533009	MER 1/4" 22 3 PB PM NC P
	1252533010	MER 1/4" 22 3 PB PM NO P

TECHNICAL DATA

Working pressure 1÷10 bar (0,10÷1,00 Mpa)

Weight 0,087 kg

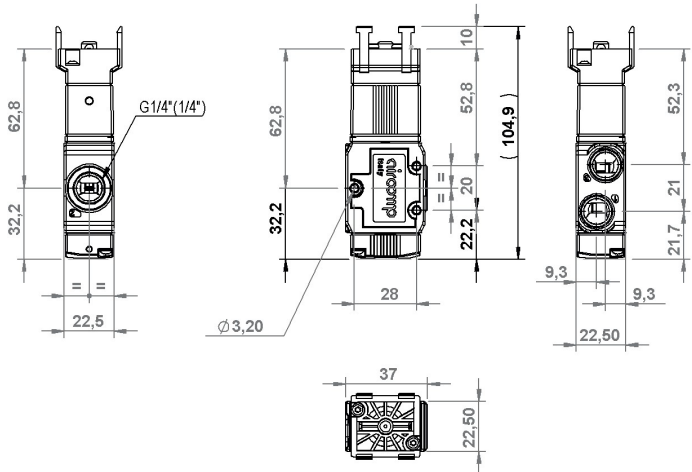

AIR PREPARATION

VALVES

CYLINDERS

FITTINGS

WATER PREPARATION

VALVES 5/2 PRE-SET FOR PANEL MOUNTING ACTUATORS



	CODE	REFERENCES
	1252535005	MER 1/4" 22 5 PB PM OO P

TECHNICAL DATA

Working pressure 1÷10 Bar (0,10÷1,00 MPa)

Weight 0,105 kg

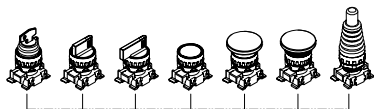
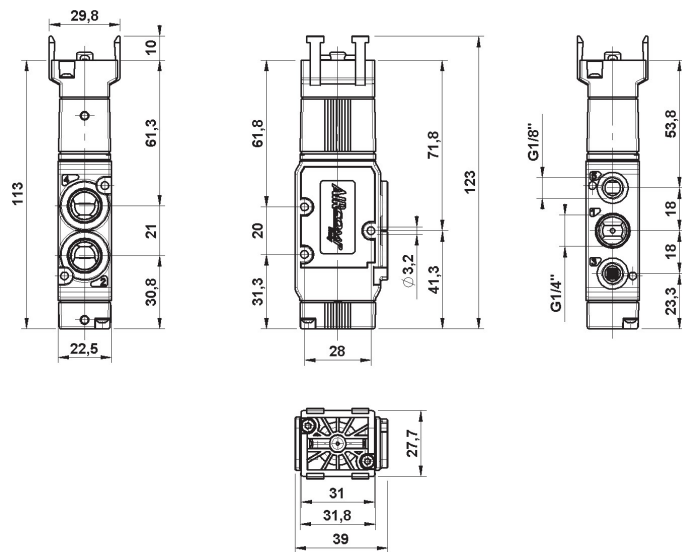

For actuators code and features, refer to page 2.87

LINE 127-1/4" | VALVES FOR PANEL MOUNTING ACTUATORS

AIR PREPARATION

VALVES

CYLINDERS

FITTINGS

WATER PREPARATION

3/2 VALVES FOR PANEL MOUNTING ACTUATORS



CODE	REFERENCES
 1272533009	MER 1/4" 22 3 PB PM NC M
 1272533010	MER 1/4" 22 3 PB PM NO M

TECHNICAL DATA

Working pressure 1±10 Bar (0,10±1,00 MPa)
Weight 0,138 kg

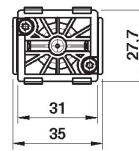
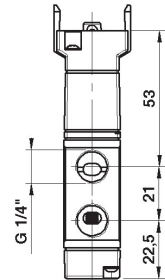
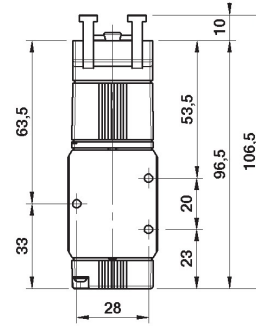
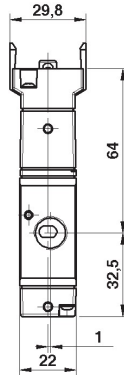

5/2 VALVES FOR PANEL MOUNTING ACTUATORS



CODE	REFERENCES
 1272535002	MER 1/4" 22 5 PB PM OO M

TECHNICAL DATA

Working pressure 1±10 Bar (0,10±1,00 MPa)
Thrust force (a 6 Bar) 4,5 N
Weight 0,146 kg

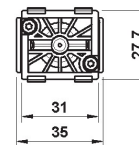
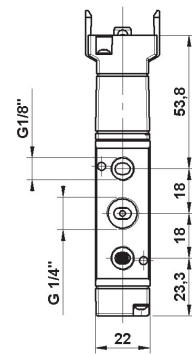
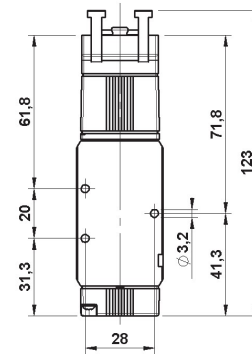
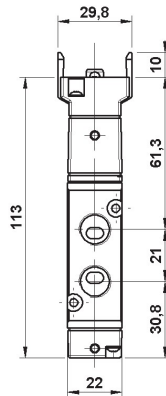

AVAILABLE CONFIGURATIONS (*)

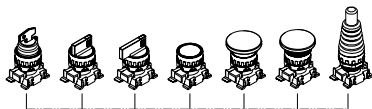

For actuators code and features, refer to page 2.87

LINE 100-120-125-127 | PANEL ACTUATORS

PUSH-BUTTON PROTECTION



COLOR	CODE	CONF.
TRANSPARENT	1003A00080	10 pieces

MUSHROOM PROTECTION



COLOR	CODE	CONF.
YELLOW	1003A00086	5 pieces

SELECTOR PROTECTION



COLOR	CODE	CONF.
GREY	1003A 00087	5 pieces

PLASTIC PLATE EMERGENCY-STOP



COLOR	CODE	Ø	CONF.
YELLOW	1003A00088	40mm	10 pieces
YELLOW	1003A00089	60mm	10 pieces

PLATE FOR SELECTOR (NEUTRAL)



COLOR	CODE	CONF.
BLACK	1003A00090	10 pieces

PANEL PLUG



COLOR	CODE	CONF.
GREY	1003A00091	10 pieces

AIR PREPARATION

VALVES

CYLINDERS

FITTINGS

WATER PREPARATION

LINE 100 M5-Ø4 | MANUAL VALVE

AIR PREPARATION

VALVES



CYLINDERS

GENERAL FEATURES

Construction	poppet type
Body size	15mm
Body material	technopolymer
Single use	YES
Combined use	NO
Available functions	Single use 2/2; 3/2; 5/3 CA; 5/3 CP

GENERAL TECHNICAL DATA

Fluid	filtered air with or without lubrication
Connections	M5; AU4
Working Pressure	2 - 10 bar -5 / +50°C (23 / 122°F)
Temperature Range	Please note: Below 3°C the air of the circuit must be free from humidity
Reference Flow Rate	P1= 6 bar; Δ P= 1 bar; 75 l/min

GUIDE TO REFERENCES

MV AU4 15 3 LT ML NC P

Product MV = Microvalve	Material P = Technopolymer
Connection AU4 = Ø4 mm Push-in fittings M5 = M5 AL4 = Ø4 mm push-in fittings (side ports) Double acting ML5 = Side ports	Option NC = Normally closed NO = Normally opened
Size 15 = 15 mm	Return ML = Spring
Function 2 = 2/2 3 = 3/2	Operation LT = Push lever DLT = Double push lever

FITTINGS

WATER PREPARATION

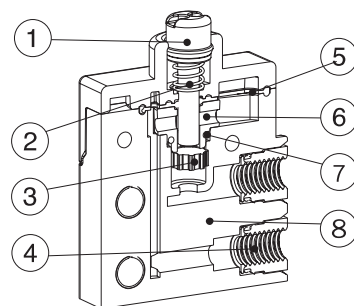
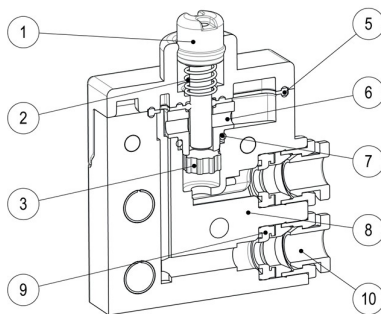

USED MATERIALS

1. **Pushrod** - POM
2. **Pushrod spring** - Stainless steel
3. **Gasket** - NBR
4. **Insert** - Brass
5. **Gasket** - NBR
6. **Nozzle** - POM
7. **O-Ring** - NBR
8. **Body** - POM
9. **Gasket** - NBR
10. **Spintore CAS** - POM

LINE 100 M5-Ø4 | MANUAL VALVE

PUSH LEVER MICROVALVES



	CODE	REFERENCES
	1000412006 1000492006	MV M5 15 2 LT ML NC P MV AU4 15 2 LT ML NC P
	1000413011 1000493011 1000493014	MV M5 15 3 LT ML NC P MV AU4 15 3 LT ML NC P MV AU4 15 3 LT ML NC P YELLOW
	1000413012 1000493012	MV M5 15 3 LT ML NO P MV AU4 15 3 LT ML NO P

TECHNICAL DATA

Thrust force (a 6 Bar) 6 N

Weight 0,028 kg

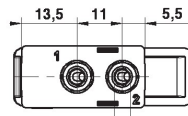

Raccordi automatici Ø4
Push-in fittings Ø4

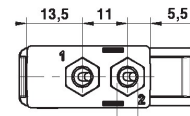

M5

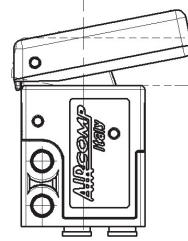

AU4 VERSION

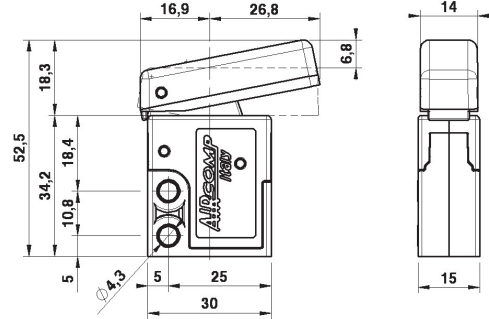

M5 VERSION

PUSH LEVER MICROVALVES WITH SIDE PORTS



	CODE	REFERENCES
	1000412106 1000492106	MV ML5 15 2 LT ML NC P MV AL4 15 2 LT ML NC P
	1000413111 1000493111 1000493114	MV ML5 15 3 LT ML NC P MV AL4 15 3 LT ML NC P MV AL4 15 3 LT ML NC P YELLOW
	1000413112 1000413112	MV ML5 15 3 LT ML NO P MV AL4 15 3 LT ML NO P

TECHNICAL DATA

Thrust force (a 6 Bar) 6 N

Weight 0,028 kg

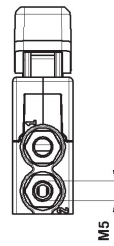

AU4 VERSION

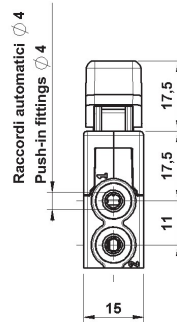

M5 VERSION

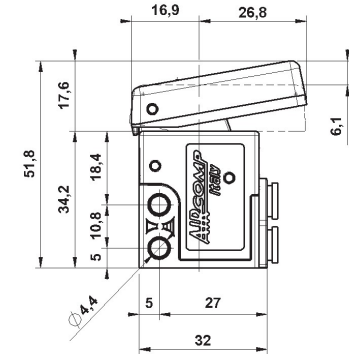

AIR PREPARATION

VALVES

CYLINDERS

FITTINGS

WATER PREPARAT

LINE 100 M5-ØD4 | MANUAL VALVE

AIR PREPARATION

VALVES

CYLINDERS

FITTINGS

WATER PREPARATION

DOUBLE PUSH LEVER MICROVALVES



	CODE	REFERENCES
	1000493018	MV AU4 15 3 DLT NC+NO P
	1000493019	MV AU4 15 3 DLT NC+NC P
	1000493020	MV AU4 15 3 DLT NO+NO P

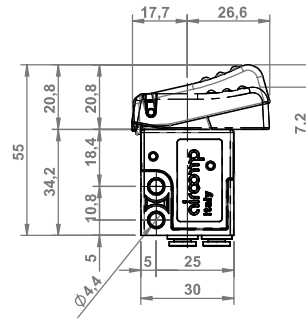
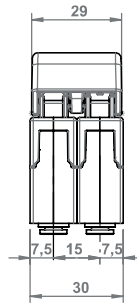
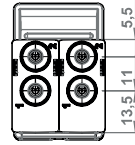

TECHNICAL DATA

Thrust force (a 6 bar) 10 N

Weight 0,053 kg

DOUBLE PUSH LEVER MICROVALVES WITH SIDE PORTS



	CODE	REFERENCES
	1000493130	MV AL4 15 3 DLT NC+NO P
	1000493132	MV AL4 15 3 DLT NC+NC P
	1000493131	MV AL4 15 3 DLT NO+NO P

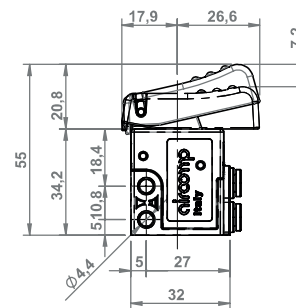
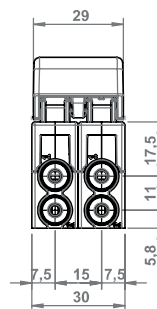

TECHNICAL DATA

Thrust force (a 6 bar) 10 N

Weight 0,053 kg

LINE 120 1/8" | MANUAL VALVES



GENERAL FEATURES

Construction	spool valve
Body size	22mm
Body material	technopolymer
Single use	YES
Manifold use	NO
Available functions	3/2; 5/2; 5/3

GENERAL TECHNICAL DATA

Fluid	filtered air with or without lubrication
Connections	1/8"
Temperature Range	-5 / +50°C (23 / 122°F) Please note: Below 3°C the air of the circuit must be free from humidity
Reference Flow Rate	P1= 6 bar; Δ P= 1 bar; 5/2= 670 (l/min), 5/3= 550 (l/min), 3/2= 690 l/min

GUIDE TO REFERENCES

VM 1/8" 22 3 L9 ML NC P

Product VM = Manual valves	Material P = Technopolymer
Connection 1/8" = G1/8"	Option NC = Normally closed NO = Normally opened CC = Closed centres CA = Opened centres CA = Pressure centre OO = 5/2
Size 22 = 22 mm	Return ML = Spring PM = Pneum. mech. spring BS = Bistable ST = Stable on 3 position RC = Return to centre MP = Pneumatic spring
Function 3 = 3/2 5 = 5/2 6 = 5/3	Operation LS = Sensible taste lever TA = Push-pull LV = Axial lever L9 = 90° lever LC = Short lever TCA = Short push-pull

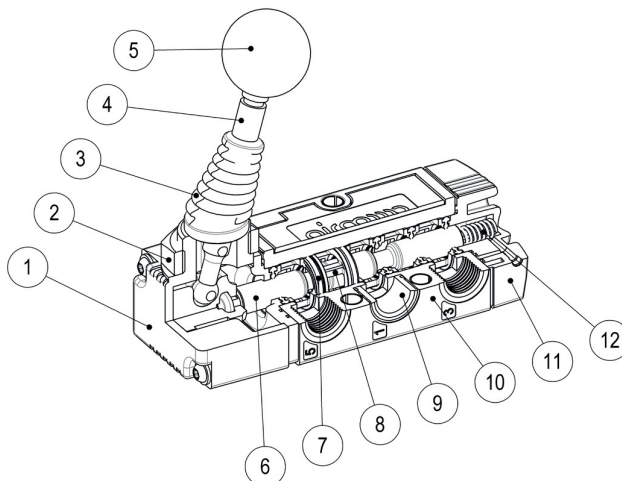

USED MATERIALS

1. Operator body - PA+FV
2. Nut - Galvanized Steel
3. Cover - NBR
4. Lever Pin - Galvanized Steel
5. Handle - Resin
6. Spool - Nickel Plated Aluminium
7. Gasket - NBR
8. Spacers - Brass
9. Insert - Brass
10. Body valve - PBT+FV
11. Base command - PA+FV
12. Spring - Stainless steel

AIR PREPARATION

VALVES

CYLINDERS

FITTINGS

WATER PREPARATION

LINE 120 VM 1/8" | MANUAL VALVES

AIR PREPARATION

VALVES

3/2 90° LEVER VALVES



	CODE	REFERENCES
	1202323006	VM 1/8" 22 3 L9 ML NC P
	1202323007	VM 1/8" 22 3 L9 BS OO P
	1202323017	VM 1/8" 22 3 LC BS OO P

TECHNICAL DATA

Working pressure 0÷10 Bar (0÷1,00 MPa)

Weight 0,091 kg

Note: for LC version, please contact our Sales Dept.

CYLINDERS

FITTINGS

WATER PREPARATION

5/2 - 5/3 90° LEVER VALVES



	CODE	REFERENCES
	1202325005	VM 1/8" 22 5 L9 ML OO P
	1202325006	VM 1/8" 22 5 L9 BS OO P
	1202326007	VM 1/8" 22 6 L9 ST CC P
	1202326008	VM 1/8" 22 6 L9 ST CA P
	1202326009	VM 1/8" 22 6 L9 ST CP P
	1202326010	VM 1/8" 22 6 L9 RC CC P
	1202326011	VM 1/8" 22 6 L9 RC CA P
	1202326012	VM 1/8" 22 6 L9 RC CP P

TECHNICAL DATA

Working pressure 0÷10 Bar (0÷1,00 MPa)

Weight 0,101 kg

Note: for LC version, please contact our Sales Dept.

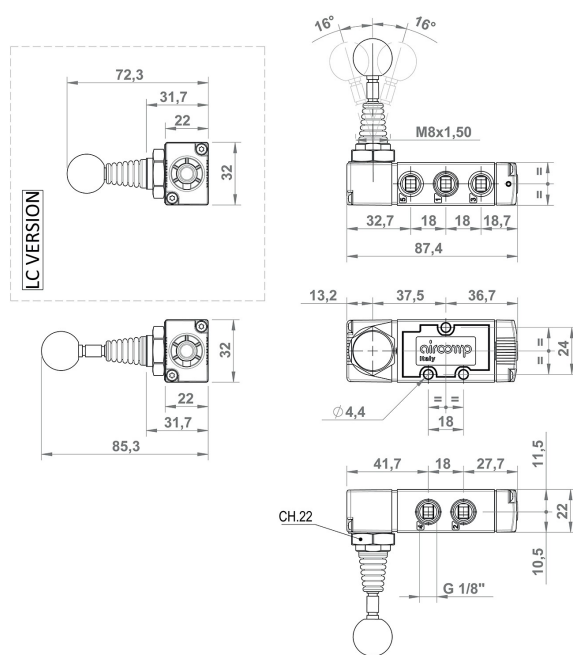
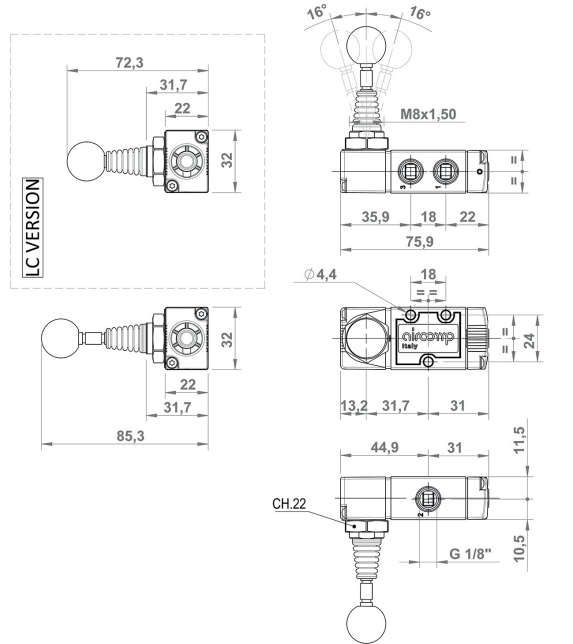

LINE 120 VM 1/8" | MANUAL VALVES

3/2 AXIAL LEVER VALVES



	CODE	REFERENCES
	1202323004	VM 1/8" 22 3 LV ML NC P
	1202323005	VM 1/8" 22 3 LV BS OO P

TECHNICAL DATA

Working pressure 0÷10 Bar (0÷1,00 MPa)

Weight 0,094 kg

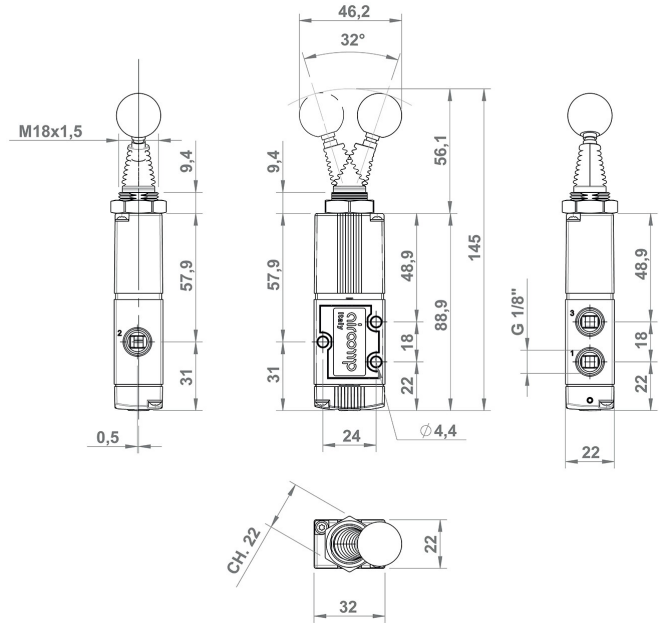

AIR PREPARATION

VALVES

CYLINDERS

FITTINGS

WATER PREPARATION

5/2 - 5/3 AXIAL LEVER VALVES



	CODE	REFERENCES
	1202325003	VM 1/8" 22 5 LV ML OO P
	1202325004	VM 1/8" 22 5 LV BS OO P
	1202326001	VM 1/8" 22 6 LV ST CC P
	1202326002	VM 1/8" 22 6 LV ST CA P
	1202326003	VM 1/8" 22 6 LV ST CP P
	1202326004	VM 1/8" 22 6 LV RC CC P
	1202326005	VM 1/8" 22 6 LV RC CA P
	1202326006	VM 1/8" 22 6 LV RC CP P

TECHNICAL DATA

Working pressure 0÷10 Bar (0÷1,00 MPa)

Weight 0,099 kg

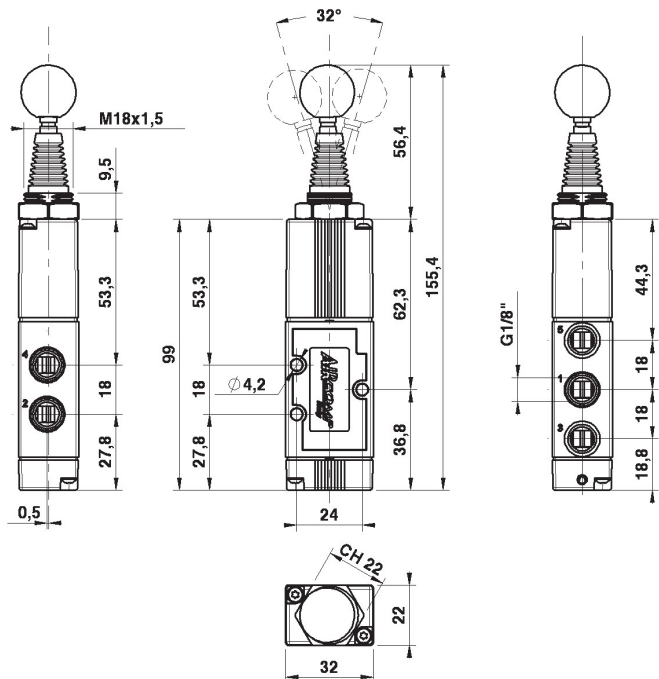

LINE 120 VM 1/8" | MANUAL VALVES

AIR PREPARATION

VALVES

3/2 DETENTED PUSH-PULL OPERATED VALVES



	CODE	REFERENCES
	1202323001	VM 1/8" 22 3 TA ML NC P
	1202323002	VM 1/8" 22 3 TA BS OO P

TECHNICAL DATA

Working pressure 0÷10 Bar (0÷1,00 MPa)

Weight 0,093 kg

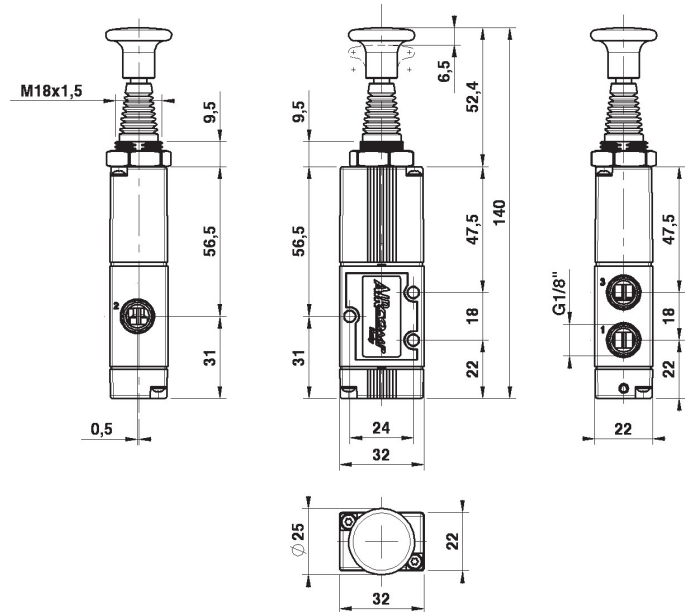

CYLINDERS

FITTINGS

5/2 - 5/3 DETENTED PUSH-PULL OPERATE VALVES



	CODE	REFERENCES
	1202325001	VM 1/8" 22 5 TA ML OO P
	1202325002	VM 1/8" 22 5 TA BS OO P
	1202326013	VM 1/8" 22 6 TA RC CC P
	1202326014	VM 1/8" 22 6 TA RC CA P
	1202326015	VM 1/8" 22 6 TA RC CP P

TECHNICAL DATA

Working pressure 0÷10 Bar (0÷1,00 MPa)

Weight 0,100 kg

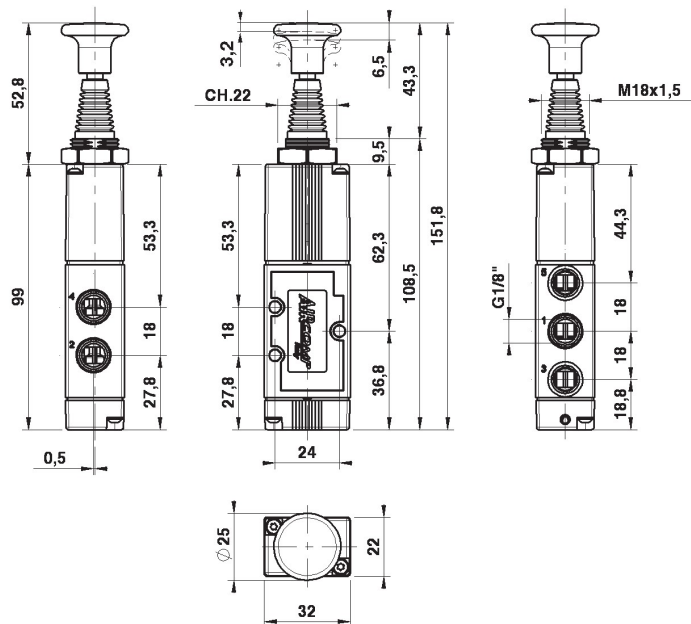

WATER PREPARATION

LINE 120 ME 1/8" | MANUAL VALVES

AIR PREPARATION

VALVES

3/2 SENSIBLE PUSH LEVER VALVES



	CODE	REFERENCES
	1202523011	ME 1/8" 22 3 LS PM NC P
	1202523012	ME 1/8" 22 3 LS PM NO P

TECHNICAL DATA

Working pressure 1±10 Bar (0,1±1,00 MPa)

Weight 0,080 kg

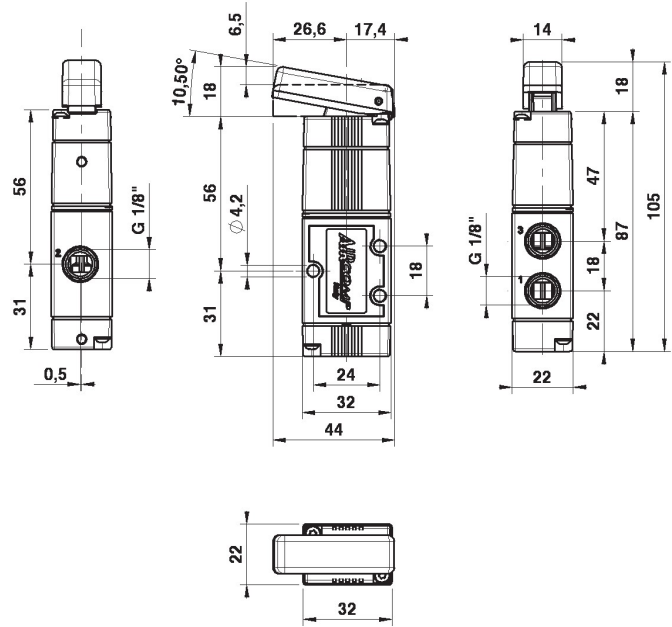

CYLINDERS

FITTINGS

5/2 SENSIBLE PUSH LEVER VALVES



	CODE	REFERENCES
	1202525006	ME 1/8" 22 5 LS PM OO P

TECHNICAL DATA

Working pressure 1±10 Bar (0,10±1,00 MPa)

Weight 0,087 kg

Note. For LC versions please contact our Sales Department

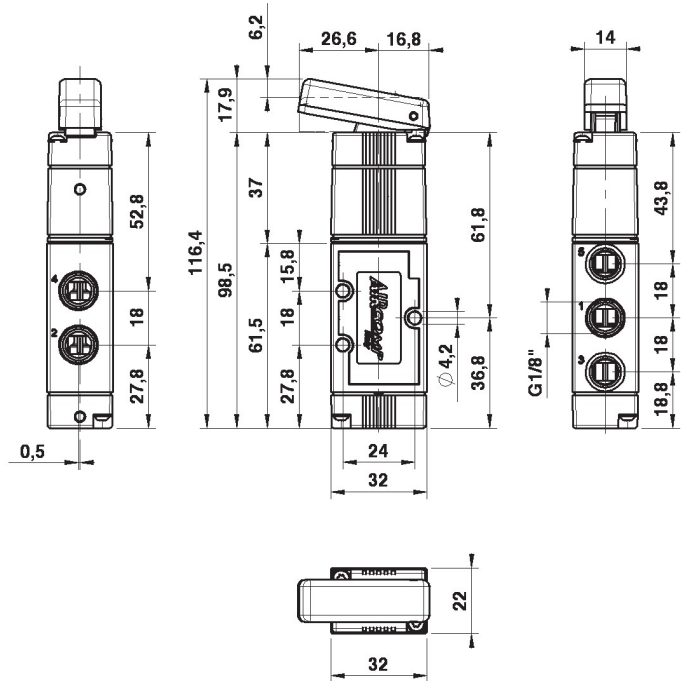

LINE 125 VMR 1/4" | MANUAL VALVES



GENERAL FEATURES

Construction	spool valve
Body size	22mm
Body material	technopolymer
Single use	YES
Manifold use	YES
Available functions	3/2, 5/2; 5/3

GENERAL TECHNICAL DATA

Fluid	filtered air with or without lubrication
Connections	1/8" - 1/4"
Temperature Range	-5 / +50°C (23 / 122°F) Please note: Below 3°C the air of the circuit must be free from humidity
Reference Flow Rate	P1= 6 bar; Δ P= 1 bar; 5/2= 800 l/min 5/3= 750 l/min 3/2= 800 l/min

GUIDE TO REFERENCES

VMR 1/4" 22 5 L9 ML 00 P

Product	VMR = Manual valves	Material	P = Technopolymer
Connection	1/4" = G1/4"	Option	CC = Closed centres NC = Normally closed CA = Opened centres CP = Pressure centre NO = Normally opened OO = 5/2
Size	22 = 22 mm	Return	ML = Spring BS = Bistable ST = Stable on 3 position RC = Return to centre MP = Pneumatic spring
Function	3 = 3/2 5 = 5/2 6 = 5/3	Operation	LS = Sensible taste lever TA = Push-pull LV = Axial lever L9 = 90° lever LC = Short lever TCA = Short push-pull

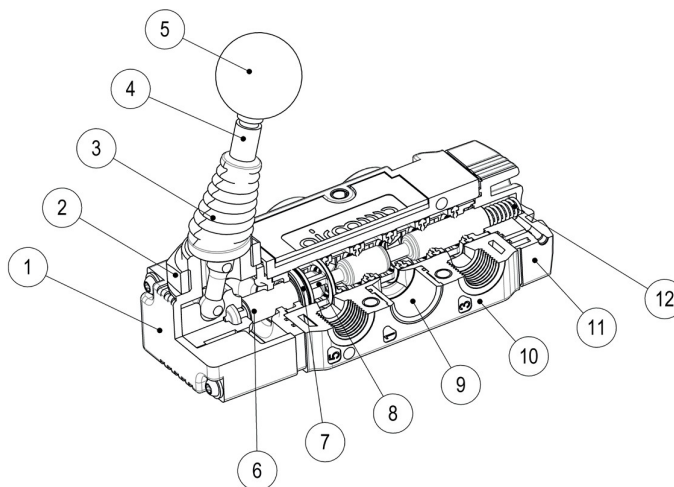

USED MATERIALS

1. **Operator body** - PA+FV
2. **Nut** - Galvanized Steel
3. **Cover** - NBR
4. **Lever Pin** - Galvanized Steel
5. **Handle** - Resin
6. **Spool** - Nickel Plated Aluminium
7. **Gasket** - NBR
8. **Spacers** - Brass
9. **Insert** - Brass
10. **Body valve** - PBT+FV
11. **Base command** - PA+FV
12. **Spring** - Stainless steel

LINE 125 VMR 1/4" | MANUAL VALVES

3/2 AXIAL LEVER VALVES



	CODE	REFERENCES
	1252333004	VMR 1/4" 22 3 LV ML NC P
	1252333005	VMR 1/4" 22 3 LV BS OO P

TECHNICAL DATA

Working pressure 0÷10 Bar (0÷1,00 MPa)

Weight 0,107 kg

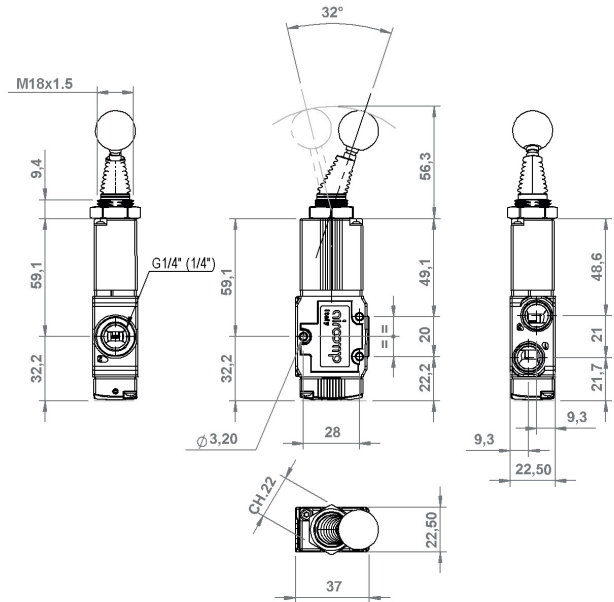

5/2 - 5/3 AXIAL LEVER VALVES



	CODE	REFERENCES
	1252335003	VMR 1/4" 22 5 LV ML OO P
	1252335004	VMR 1/4" 22 5 LV BS OOP
	1252336001	VMR 1/4" 22 6 LV ST CC P
	1252336002	VMR 1/4" 22 6 LV ST CA P
	1252336003	VMR 1/4" 22 6 LV ST CP P
	1252336004	VMR 1/4" 22 6 LV RC CC P
	1252336005	VMR 1/4" 22 6 LV RC CA P
	1252336006	VMR 1/4" 22 6 LV RC CP P

TECHNICAL DATA

Working pressure 0÷10 Bar (0÷1,00 MPa)

Weight 0,119 kg

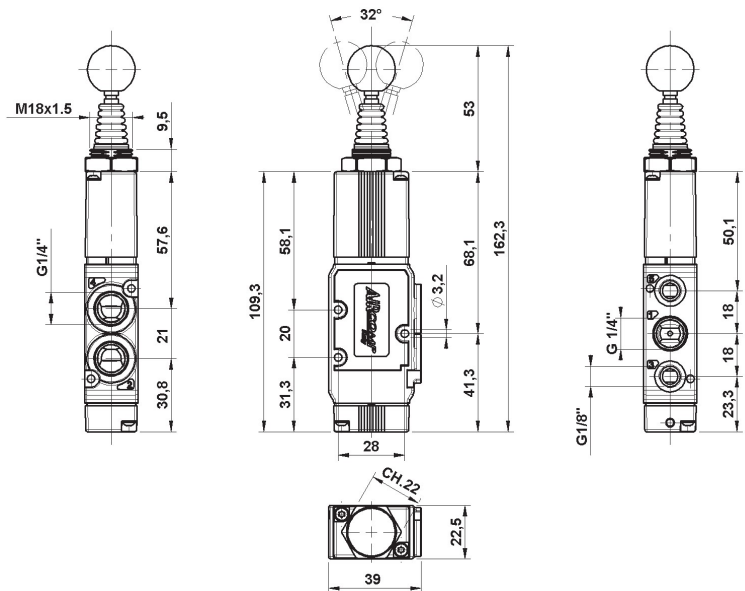

AIR PREPARATION

VALVES

CYLINDERS

FITTINGS

WATER PREPARATION

LINE 125 VMR 1/4" | MANUAL VALVES

3/2 SENSIBLE TASTE LEVER VALVES



	CODE	REFERENCES
	1252533011	MER 1/4" 22 3 LS ML NC P
	1252533012	MER 1/4" 22 3 LS ML NO P

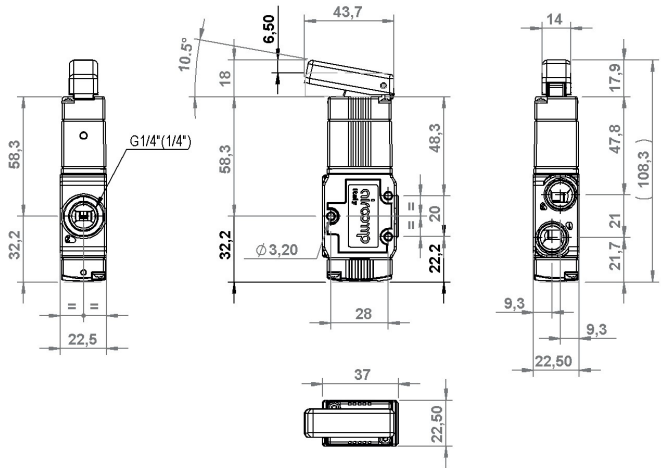

AIR PREPARATION

VALVES

CYLINDERS

FITTINGS

WATER PREPARATION

5/2 SENSIBLE TASTE LEVER VALVES



	CODE	REFERENCES
	1252535006	MER 1/4" 22 5 LS PM OO P

TECHNICAL DATA

Working pressure 1±10 Bar (0,10±1,00 MPa)

Weight 0,107 kg

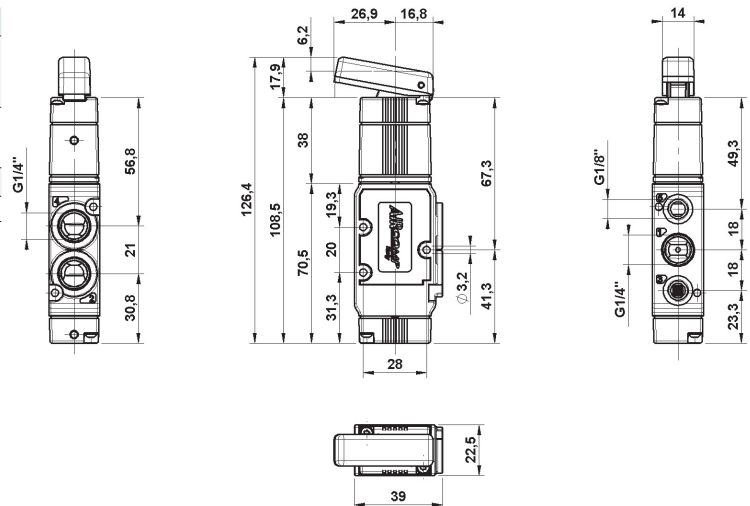

LINE 127 1/4" | MANUAL VALVES

AIR PREPARATION

VALVES



CYLINDERS

FITTINGS

WATER PREPARATION

GENERAL FEATURES

Construction	spool valve
Body size	22mm
Body material	aluminium
Single use	YES
Manifold use	NO
Available functions	3/2; 5/2; 5/3

GENERAL TECHNICAL DATA

Costruzione	spool valve
Fluid	filtered air with or without lubrication
Connections	1/4"
Temperature Range	-5 / +50°C (23 / 122°F) Please note: Below 3°C the air of the circuit must be free from humidity
Reference Flow Rate	P1= 6 bar; Δ P= 1 bar; 5/2= 800 l/min 5/3=750 l/min 3/2: 750 l/min

GUIDE TO REFERENCES

VMR 1/4" 22 3 L9 ML NC M

Product VMR = Manual valves	Material M = Metal
Connection 1/4" = G1/4"	Option NC = Normally closed NO = Normally opened CC = Closed centres CA = Opened centres CP = Pressure centre OO = 5/2
Size 22 = 22 mm	Return ML = Spring BS = Bistable ST = Stable on 3 position RC = Return to centre MP = Pneumatic spring
Function 3 = 3/2 5 = 5/2 6 = 5/3	Operation LS = Sensible taste lever TA = Push-pull LV = Axial lever L9 = 90° lever LC = Short lever TCA = Short push-pull

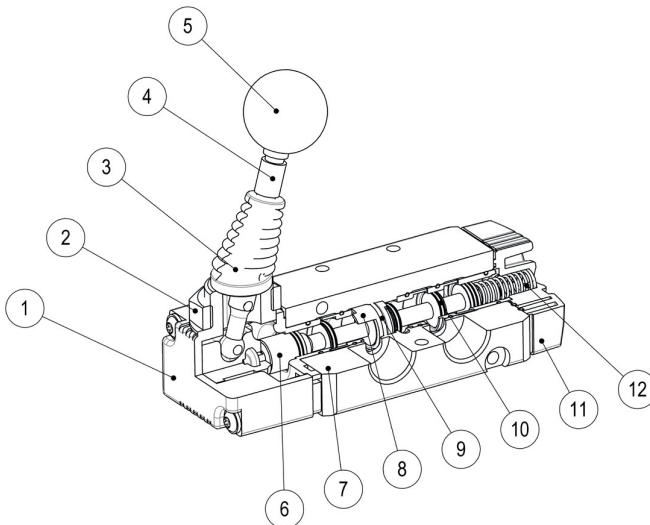

USED MATERIALS

1. Operator body - Pa+Fv
2. Nut - Galvanized Steel
3. Cover - NBR
4. Lever Pin - Galvanized Steel
5. Handle - Resin
6. Spool - Nickel Plated Aluminium
7. Body valve - Aluminium
8. Spacers - POM
9. OR spacers - NBR
10. Seals - NBR
11. Base command - Pa+Fv
12. Spring - Stainless steel

LINE 127 VMR 1/4" | MANUAL VALVES

3/2 90° LEVER VALVE



	CODE	REFERENCES
	1272333006	VMR 1/4" 22 3 L9 ML NC M
	1272333007	VMR 1/4" 22 3 L9 BS OO M

TECHNICAL DATA

Working pressure 0÷10 Bar (0÷1,00 MPa)

Weight 0,151 kg

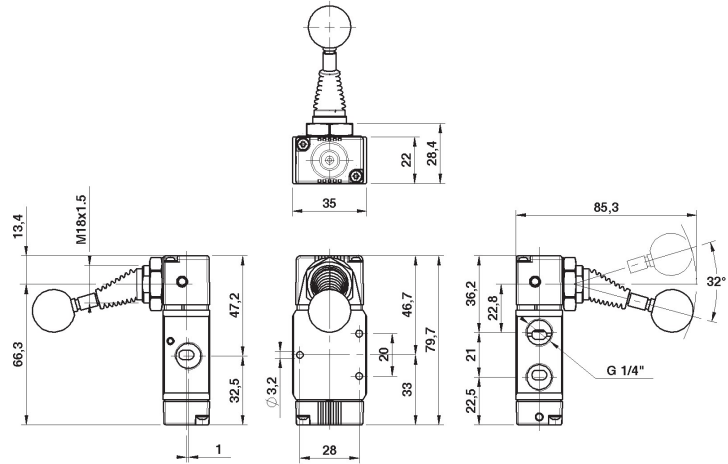

LEVER VALVE 90° 5/2 - 5/3



	CODE	REFERENCES
	1272335005	VMR 1/4" 22 5 L9 ML OO M
	1272335006	VMR 1/4" 22 5 L9 BS OO M
	1272336007	VMR 1/4" 22 6 L9 ST CC M
	1272336008	VMR 1/4" 22 6 L9 ST CA M
	1272336009	VMR 1/4" 22 6 L9 ST CP M
	1272336010	VMR 1/4" 22 6 L9 RC CC M
	1272336011	VMR 1/4" 22 6 L9 RC CA M
	1272336012	VMR 1/4" 22 6 L9 RC CP M

TECHNICAL DATA

Working pressure 0÷10 Bar (0÷1,00 MPa)

Weight 0,154 kg

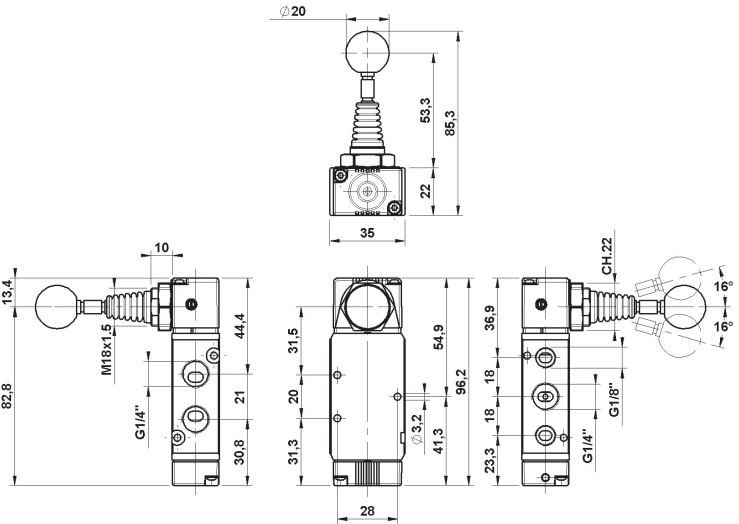

AIR PREPARATION

VALVES

CYLINDERS

FITTINGS

WATER PREPARATION

LINE 127 VMR 1/4" | MANUAL VALVES

AIR PREPARATION

VALVES

CYLINDERS

FITTINGS

WATER PREPARATION

AXIAL LEVER VALVE 3/2



	CODE	REFERENCES
	1272333004	VMR 1/4" 22 3 LV ML NC M
	1272333005	VMR 1/4" 22 3 LV BS OO M

TECHNICAL DATA

Working pressure 0±10 Bar (0±1,00 MPa)

Weight 0,154 kg

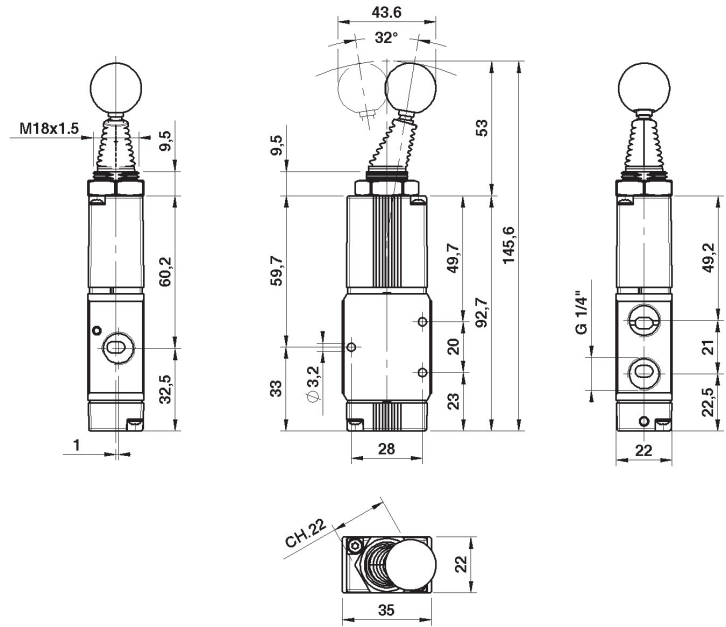

5/2 - 5/3 AXIAL LEVER VALVES



	CODE	REFERENCES
	1272335003	VMR 1/4" 22 5 LV ML OO M
	1272335004	VMR 1/4" 22 5 LV BS OO M
	1272336001	VMR 1/4" 22 6 LV ST CC M
	1272336002	VMR 1/4" 22 6 LV ST CA M
	1272336003	VMR 1/4" 22 6 LV ST CP M
	1272336004	VMR 1/4" 22 6 LV RC CC M
	1272336005	VMR 1/4" 22 6 LV RC CA M
	1272336006	VMR 1/4" 22 6 LV RC CP M

TECHNICAL DATA

Working pressure 0±10 Bar (0±1,00 MPa)

Weight 0,159 kg

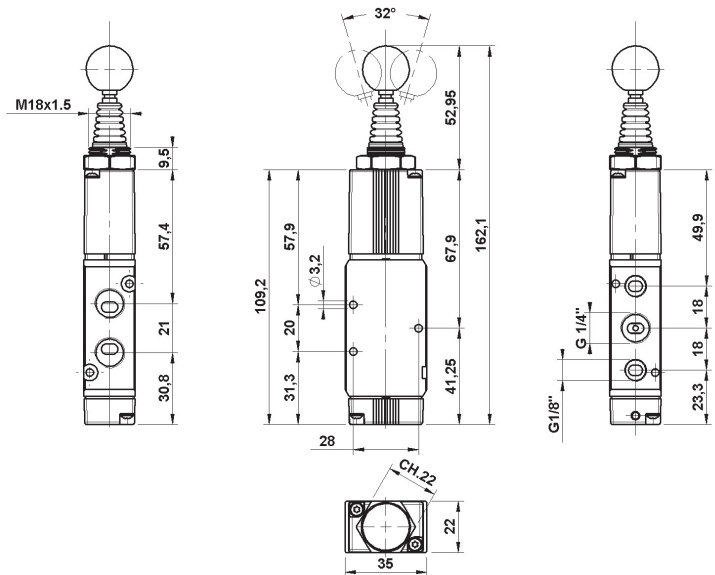

LINE 127 VMR 1/4" | MANUAL VALVES

3/2 DETENTED PUSH-PULL VALVES



	CODE	REFERENCES
	1272333001	VMR 1/4" 22 3 TA ML NC M
	1272333002	VMR 1/4" 22 3 TA BS OO M

TECHNICAL DATA

Working pressure 0÷10 Bar (0÷1,00 MPa)

Weight 0,153 kg

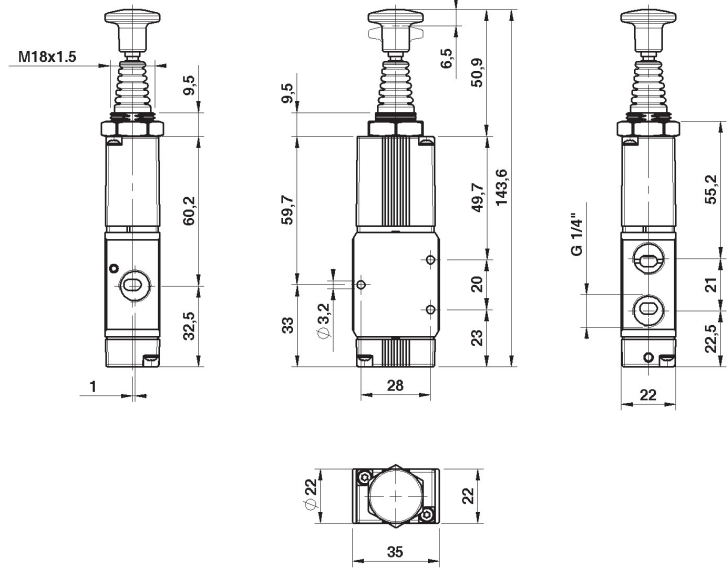

AIR PREPARATION

VALVES

CYLINDERS

FITTINGS

WATER PREPARATION

5/2 - 5/3 DETENTED PUSH-PULL VALVES



	CODE	REFERENCES
	1272335001	VMR 1/4" 22 5 TA ML OO M
	1272335002	VMR 1/4" 22 5 TA BS OO M
	1272336013	VMR 1/4" 22 6 TA RC CC M
	1272336014	VMR 1/4" 22 6 TA RC CA M
	1272336015	VMR 1/4" 22 6 TA RC CP M

TECHNICAL DATA

Working pressure 0÷10 Bar (0÷1,00 MPa)

Weight 0,160 kg

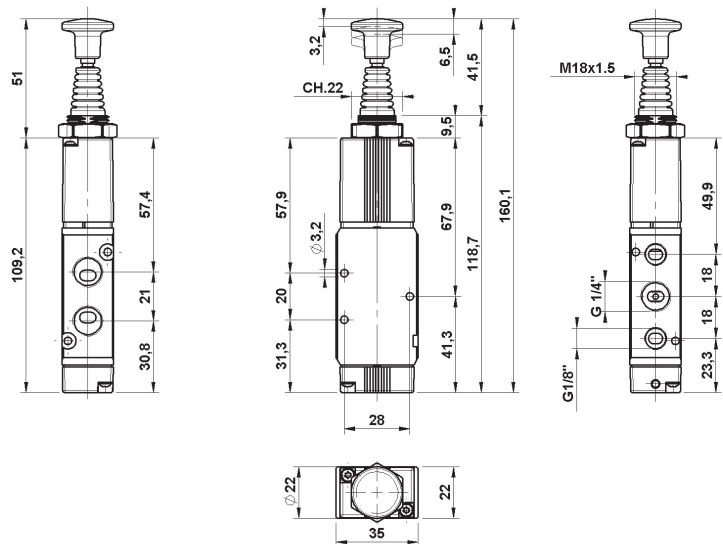

LINE 127 VMR 1/4" | MANUAL VALVES

AIR PREPARATION

SHORT PUSH-PULL VALVES 3/2



VALVES

	CODE	REFERENCES
	1272333012	VMR 1/4" 22 3 TCA ML NC M
	1272333013	VMR 1/4" 22 3 TCA BS OO M

TECHNICAL DATA

Working pressure 0÷10 Bar (0÷1,00 MPa)

Weight 0,101 kg

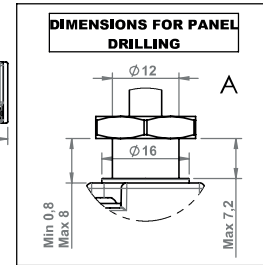
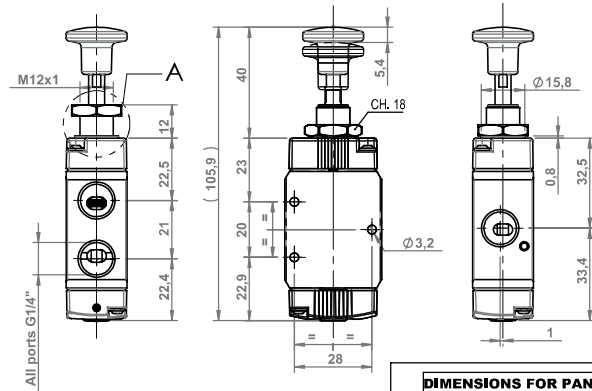

CYLINDERS

FITTINGS

SHORT PUSH-PULL VALVES 5/2



WATER PREPARATION

	CODE	REFERENCES
	1272335007	VMR 1/4" 22 5 TCA ML OO M
	1272335008	VMR 1/4" 22 5 TCA BS OO M

TECHNICAL DATA

Working pressure 0÷10 Bar (0÷1,00 MPa)

Weight 0,127 kg

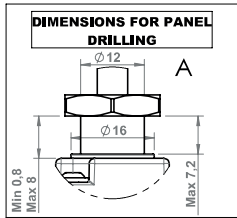
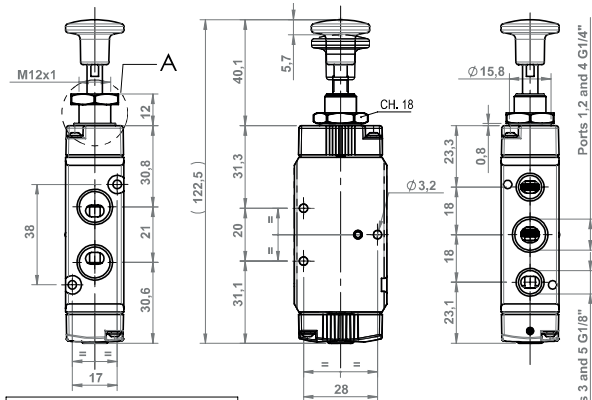

LINE 127 MER 1/4" | MANUAL VALVES

3/2 SENSIBLE PUSH LEVER VALVES



	CODE	REFERENCES
	1272533011	MER 1/4" 22 3 LS PM NC M
	1272533012	MER 1/4" 22 3 LS PM NO M

TECHNICAL DATA

Working pressure 1+10 Bar (0,01+1,00 MPa)

Weight 0,140 kg

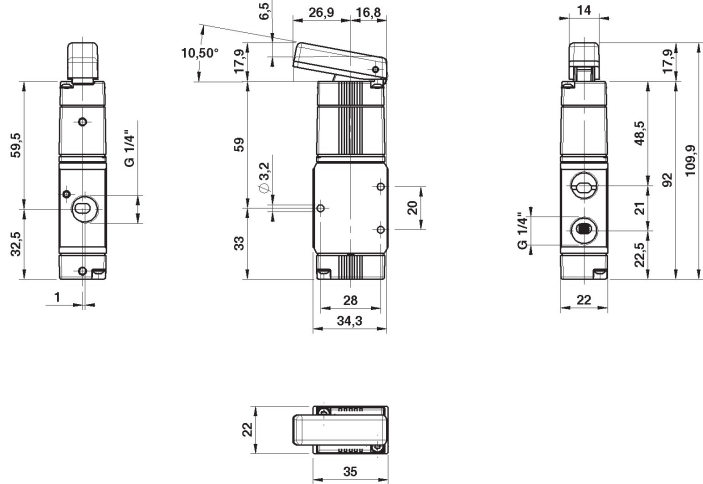

5/2 SENSIBLE PUSH LEVER VALVES



	CODE	REFERENCES
	1272535006	MER 1/4" 22 5 LS PM OO M

TECHNICAL DATA

Working pressure 1+10 Bar (0,10+1,00 MPa)

Weight 0,148 kg

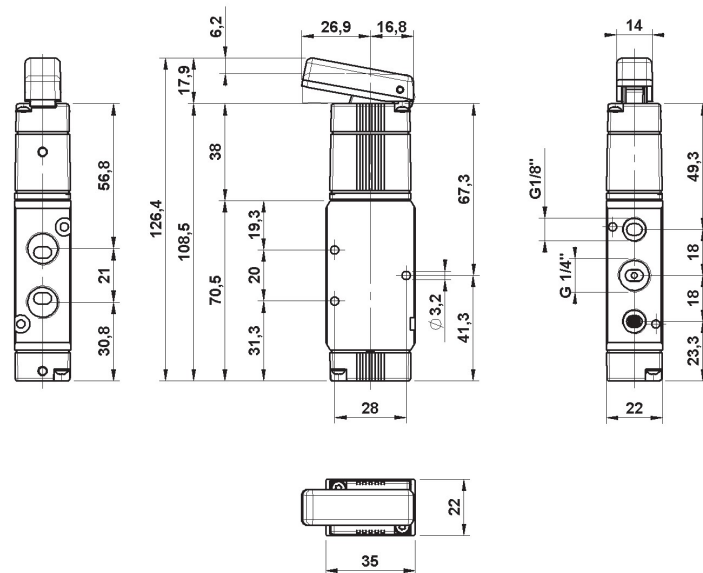

AIR PREPARATION

VALVES

CYLINDERS

FITTINGS

WATER PREPARATION

LINE 130 VM 1/2" | MANUAL VALVES

AIR PREPARATION

VALVES

CYLINDERS

FITTINGS

WATER PREPARATION



GENERAL FEATURES

Construction	spool valve
Body material	Metal
Single use	YES
Manifold use	NO
Available functions	5/2 5/3

GENERAL TECHNICAL DATA

Fluid	filtered air with or without lubrication
Connections	1/2"
Temperature Range	-5 / +50°C (23/122°F) Please note: Below 3°C the air of the circuit must be free from humidity
Reference Flow Rate	P1= 6 bar; Δ P= 1 bar 5/2= 2.500 l/min 5/3= 2.500 l/min

GUIDE TO REFERENCES

VM 1/2" 30 5 L9 ML 00 M

Product VM = Manual valves	Material M = Metal
Connection 1/2" = G1/2"	Option CC = Closed centres CA = Opened centres CA = Pressure centre 00 = 5/2
Size 30 = 30 mm	Return ML = Spring BS = Bistable ST = Stable on 3 position RC = Return to centre
Function 5 = 5/2 6 = 5/2	Operation L9 = 90° lever

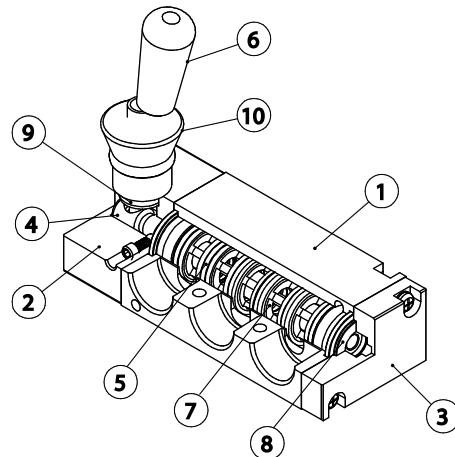

USED MATERIALS

- Body valve** - Aluminium
- Operator body** - Aluminium
- Base command** - Aluminium
- Spool** - Stainless steel
- Gasket** - Rubber
- Leva** - Metal, Technopolymer
- Spacers** - Technopolymer
- Centering ring** - Aluminium
- Cover** - Gomma

LINE 130 VM 1/2" | MANUAL VALVES

LEVER VALVE 90° 5/2 SPRING RETURN



CODE	REFERENCES
1304355005	VM 1/2" 30 5 L9 ML OO M

TECHNICAL DATA

Connection size G1/2"

Working pressure 0÷10 Bar (0÷1,00 MPa)

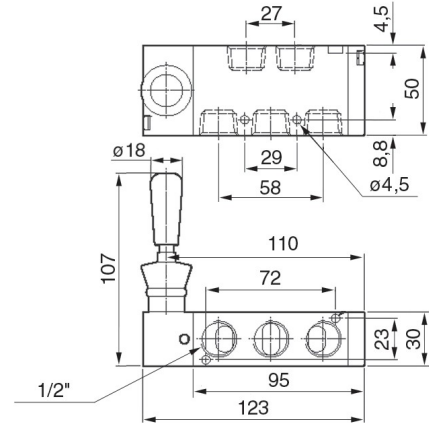

LEVER VALVE 90° 5/2 - 5/3 RETURN TO CENTRE



CODE	REFERENCES
1304356010	VM 1/2" 30 5 L9 RC CC M
1304356011	VM 1/2" 30 5 L9 RC CA M

TECHNICAL DATA

Connection size G1/2"

Working pressure 0÷10 Bar (0÷1,00 MPa)

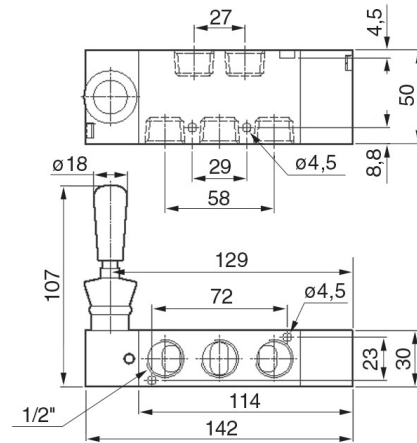

LEVER VALVE 90° 5/2 - 5/3 FIXED POSITIONS



CODE	REFERENCES
1304355006	VM 1/2" 30 5 L9 BS OO M
1304356007	VM 1/2" 30 5 L9 ST CC M
1304356008	VM 1/2" 30 5 L9 ST CA M

TECHNICAL DATA

Connection size G1/2"

Working pressure 0÷10 Bar (0÷1,00 MPa)

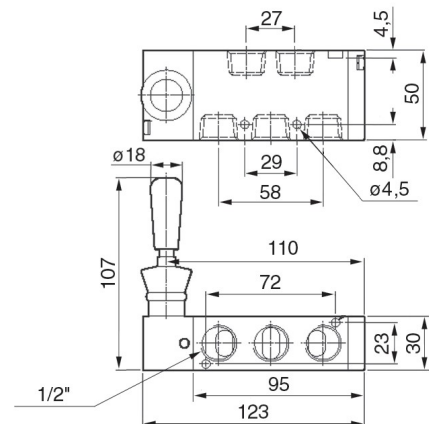

AIR PREPARATION

VALVES

CYLINDERS

FITTINGS

WATER PREPARATION

LINE 130 VM 1/4"-1/2"-3/4" | HAND SWITCH VALVES

AIR PREPARATION

VALVES

CYLINDERS

FITTINGS

WATER PREPARATION



GENERAL FEATURES

Construction	Hand switch
Body size	62mm; 74mm; 102mm
Body material	Metal
Single use	YES
Manifold use	NO
Available functions	4/2 bistable; 4/3 closed centre, open centre

Note: panel fixing nut supplied separately

GENERAL TECHNICAL DATA

Fluid	filtered air with or without lubrication
Connections	1/4" - 1/2" - 3/4"
Temperature Range	-5 / +50°C (23 / 122°F) Please note: Below 3°C the air of the circuit must be free from humidity
Reference Flow Rate	P1= 6 bar; ΔP= 1 bar; size 62 = 360 l/min; size 74 = 1.300 l/min; size 02 = 3.600 l/min
Working Pressure	(0,05 ÷ 1,00 MPa)

GUIDE TO REFERENCES

VM 1/4 62 4A LR ST C M

Product VM = Manual valve	Material M = Metal
Function 1/4 = G1/4" 1/2 = G1/2" 3/4 = G3/4"	Option CC = Closed centres CA = Opened centres OO = 5/2
Size 62 = 62 mm 74 = 74 mm 02 = 102 mm	Return ST = Stable on 3 position BS = Bistable
Function 4 = 4/2 4A = 4/3	Operation LR = Hand Switch

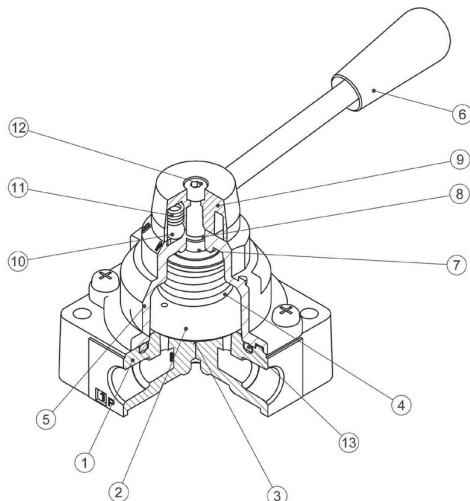

USED MATERIALS

- Body valve:** Aluminium
- Internal Bell:** Technopolymer
- Pin:** Steel
- Spring:** Steel
- Cover:** Aluminium
- Handle:** Technopolymer
- Control Shaft:** Steel
- O-Ring:** NBR
- Lever Base:** Zinc alloy

LINE 130 VM 1/4"-1/2"-3/4" | HAND SWITCH VALVES

SIZE 62 VALVES



	CODE	REFERENCES
	1300334001	VM 1/4" 62 4 LR BS OO M
	1300337001	VM 1/4" 62 4A LR ST CC M
	1300337002	VM 1/4" 62 4A LR ST CA M

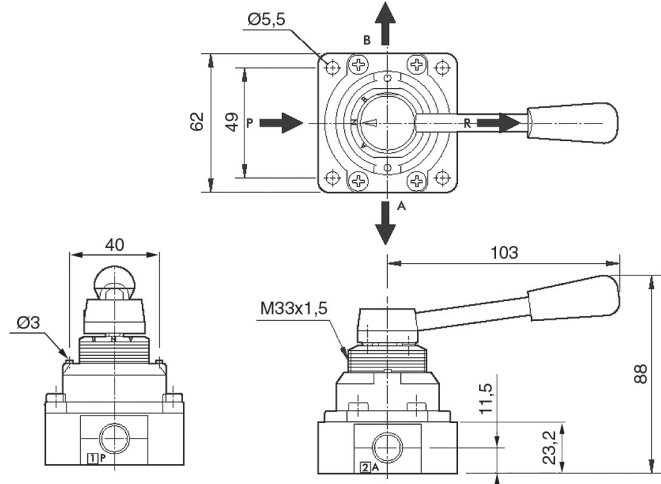

SIZE 74 VALVES



	CODE	REFERENCES
	1300354001	VM 1/2" 74 4 LR BS OO M
	1300357001	VM 1/2" 74 4A LR ST CC M
	1300357002	VM 1/2" 74 4A LR ST CA M

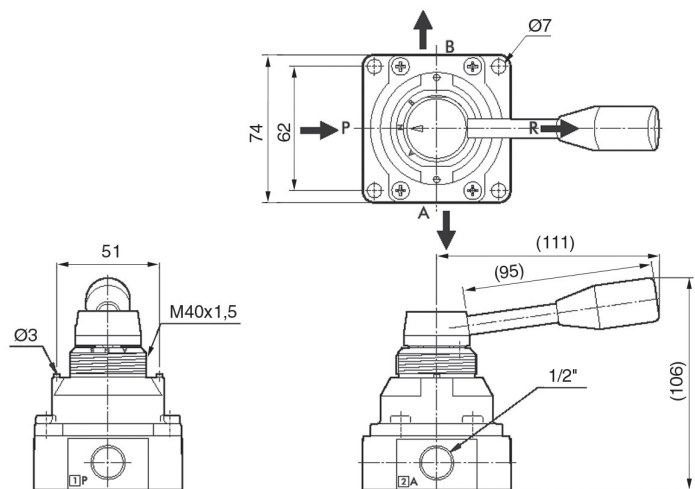

AIR PREPARATION

VALVES

CYLINDERS

FITTINGS

WATER PREPARATION

LINE 130 VM 1/4"-1/2"-3/4" | HAND SWITCH VALVES

AIR PREPARATION

SIZE 02 VALVES



VALVES

	CODE	REFERENCES
	1300384001	VM 3/4 02 4 LR BS OO M

	1300387001	VM 3/4 02 4A LR ST CC M
--	------------	-------------------------

	1300387002	VM 3/4 02 4A LR ST CA M
--	------------	-------------------------

CYLINDERS

FITTINGS

WATER PREPARATION

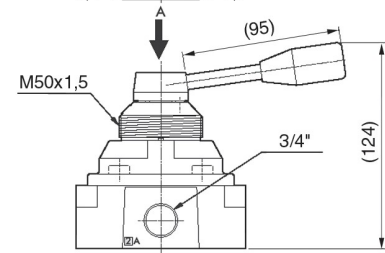
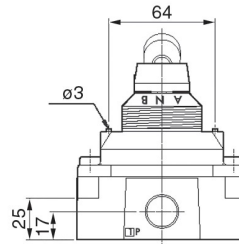
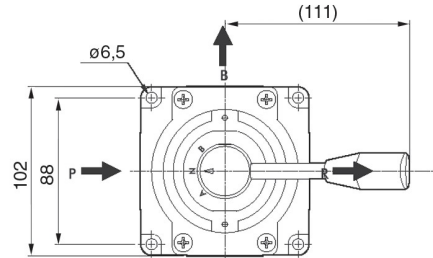

ACCESSORIES AND SPARE PARTS

CODE	REFERENCES
1393A00001	NUT M33 x 1,5 PER VM 1/4"
1393A00002	NUT M40 x 1,5 PER VM 1/2"
1393A00003	NUT M50 x 1,5 PER VM 3/4"



CODE	REFERENCES
1393A00004	COMPLETE LEVER VM 1/4"
1393A00005	COMPLETE LEVER VM 1/2"



LINE 100 M5-Ø4 | MECHANICAL VALVES



AIR PREPARATION

VALVES

CYLINDERS

FITTINGS

WATER PREPARATION

GENERAL FEATURES

Construction	poppet type
Body size	15mm
Body material	technopolymer
Single use	YES
Combined use	NO
Available functions	Single use 2/2; 3/2 Combined use 5/3 CA; 5/3 CP

GENERAL TECHNICAL DATA

Fluid	filtered air with or without lubrication
Connections	M5; AU4
Working Pressure	2 - 10 bar
Temperature Range	-5 / +50°C (23 / 122°F) Please note: Below 3°C the air of the circuit must be free from humidity
Reference Flow Rate	P1= 6 bar; Δ P= 1 bar; 75 l/min

GUIDE TO REFERENCES

MV AU4 15 3 PU ML NC P

Product MV = Microvalve	Material P = Technopolymer
Connection AU4 = Ø4 mm Push-in fittings M5 = M5 AL4 = Ø4 mm push-in fittings (side ports) Double acting ML5 = Side ports	Option NC = Normally closed NO = Normally opened
Size 15 = 15 mm	Return ML = Spring
Function 2 = 2/2 3 = 3/2	Operation PU = Pushrod PP = through-wall pushrod RL = Roller lever RU = Undirectional roller lever

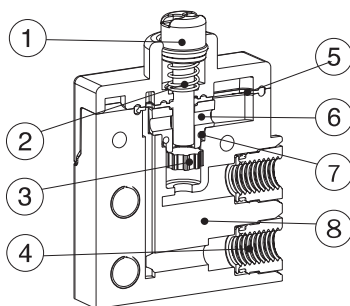
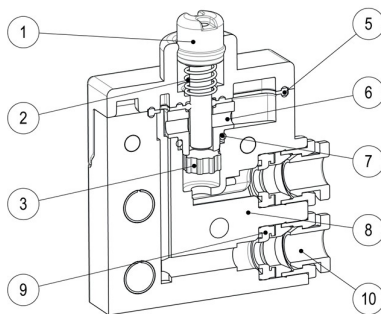

USED MATERIALS

1. Pushrod - POM
2. Pushrod Spring - Stainless-
3. Gasket - NBR
4. Insert - Brass
5. Gasket - NBR
6. Nozzle - POM
7. O-Ring - NBR
8. Body - POM
9. Seal - NBR
10. Spintore CAS - POM

LINE 100 M5-Ø4 | MECHANICAL VALVES

AIR PREPARATION

VALVES

ROLLER LEVER MICROVALVES



	CODE	REFERENCES
	1000412002	MV M5 15 2 RL ML NC P
	1000492002	MV AU4 15 2 RL ML NC P
	1000413003	MV M5 15 3 RL ML NC P
	1000493003	MV AU4 15 3 RL ML NC P
	1000413004	MV M5 15 3 RL ML NO P
	1000493004	MV AU4 15 3 RL ML NO P

TECHNICAL DATA

Thrust force (a 6 Bar) 6 N

Weight 0,027 kg

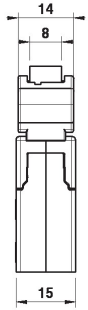
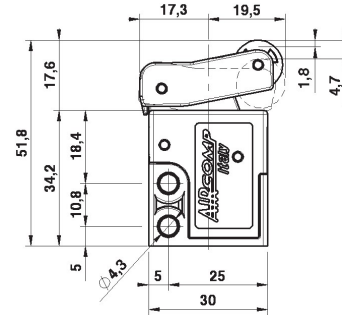
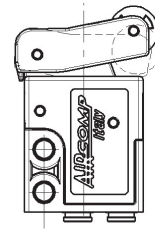
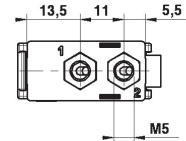
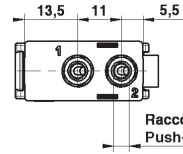

AU4 VERSION

M5 VERSION

CYLINDERS

FITTINGS

ROLLER LEVER MICROVALVES WITH SIDE PORTS



	CODE	REFERENCES
	1000412102	MV ML5 15 2 RL ML NC P
	1000492102	MV AL4 15 2 RL ML NC P
	1000413103	MV ML5 15 3 RL ML NC P
	1000493103	MV AL4 15 3 RL ML NC P
	1000413104	MV ML5 15 3 RL ML NO P
	1000493104	MV AL4 15 3 RL ML NO P

TECHNICAL DATA

Thrust force (a 6 Bar) 6 N

Weight 0,027 kg

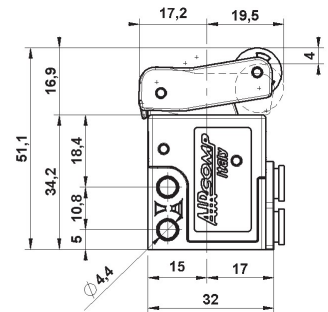
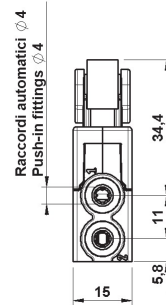
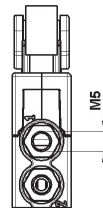

AU4 VERSION

M5 VERSION

WATER PREPARATION

LINE 100 M5-Ø4 | MECHANICAL VALVES

UNIDIRECTIONAL ROLLER LEVER MICROVALVES



	CODE	REFERENCES
	1000412003 1000492003	MV M5 15 2 RU ML NC P MV AU4 15 2 RU ML NC P
	1000413005 1000493005	MV M5 15 3 RU ML NC P MV AU4 15 3 RU ML NC P
	1000413006 1000493006	MV M5 15 3 RU ML NO P MV AU4 15 3 RU ML NO P

TECHNICAL DATA

Thrust force (a 6 Bar) 6 N

Weight 0,031 kg

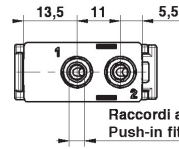

Raccordi automatici Ø4
Push-in fittings Ø4

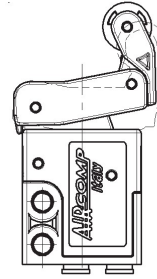
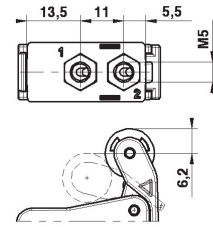

AU4 VERSION

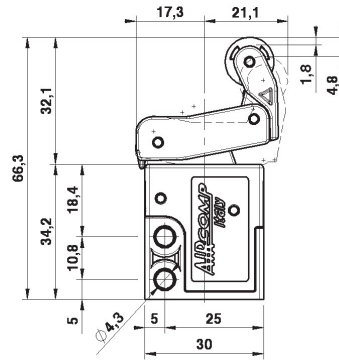

M5 VERSION

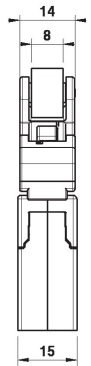

AIR PREPARATION

VALVES

CYLINDERS

FITTINGS

WATER PREPARATION

UNIDIRECTIONAL ROLLER LEVER MICROVALVES WITH SIDE PORTS



	CODE	REFERENCES
	1000412103 1000492103	MV ML5 15 2 RU ML NC P MV AL4 15 2 RU ML NC P
	1000413105 1000493105	MV ML5 15 3 RU ML NC P MV AL4 15 3 RU ML NC P
	1000413106 1000493106	MV ML5 15 3 RU ML NO P MV AL4 15 3 RU ML NO P

TECHNICAL DATA

Thrust force (a 6 Bar) 6 N

Weight 0,031 kg

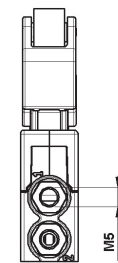
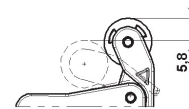

AU4 VERSION

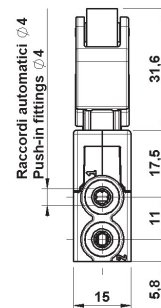

M5 VERSION

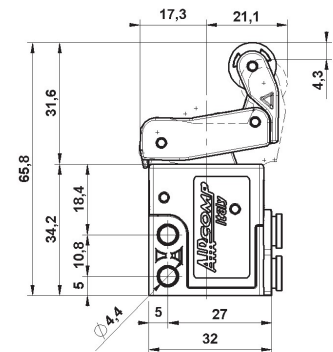

LINE 100 M5-Ø4 | MECHANICAL VALVES

AIR PREPARATION

VALVES

CYLINDERS

FITTINGS

WATER PREPARATION

THROUGH-WALL PUSHROD MICROVALVES



	CODE	REFERENCES
	1000412004 1000492004	MV M5 15 2 PP ML NC P MV AU4 15 2 PP ML NC P
	1000413007 1000493007	MV M5 15 3 PP ML NC P MV AU4 15 3 PP ML NC P
	1000413008 1000493008	MV M5 15 3 PP ML NO P MV AU4 15 3 PP ML NO P

TECHNICAL DATA

Thrust force (a 6 Bar) 8 N

Weight 0,029 kg

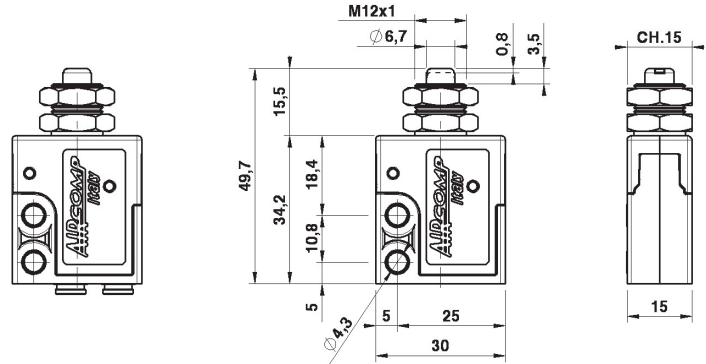
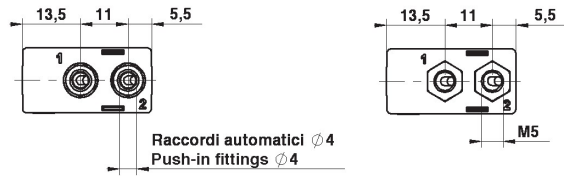

AU4 VERSION

M5 VERSION

THROUGH-WALL PUSHROD MICROVALVES WITH SIDE PORTS



	CODE	REFERENCES
	1000412104 1000492104	MV ML5 15 2 PP ML NC P MV AL4 15 2 PP ML NC P
	1000413107 1000493107	MV ML5 15 3 PP ML NC P MV AL4 15 3 PP ML NC P
	1000413108 1000493108	MV ML5 15 3 PP ML NO P MV AL4 15 3 PP ML NO P

TECHNICAL DATA

Thrust force (a 6 Bar) 8 N

Weight 0,029 kg

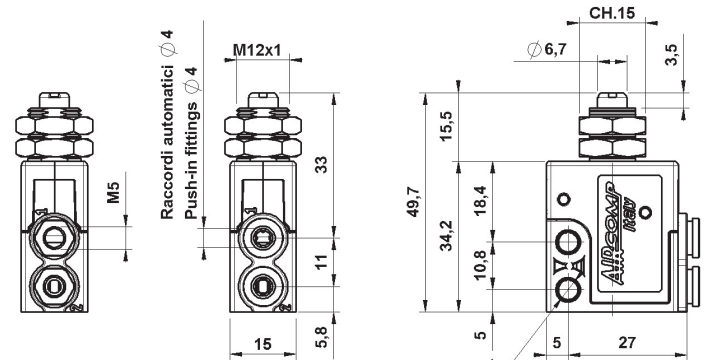

ML5 VERSION

AL4 VERSION

LINE 100 M5-Ø4 | MECHANICAL VALVES

PUSHROD MICROVALVES



	CODE	REFERENCES
	1000412001 1000492001	MV M5 15 2 PU ML NC P MV AU4 15 2 PU ML NC P
	1000413001 1000493001	MV M5 15 3 PU ML NC P MV AU4 15 3 PU ML NC P
	1000413002 1000493002	MV M5 15 3 PU ML NO P MV AU4 15 3 PU ML NO P

TECHNICAL DATA

Thrust force (a 6 Bar) 8 N

Weight 0,024 kg

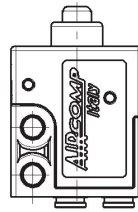

AU4 VERSION

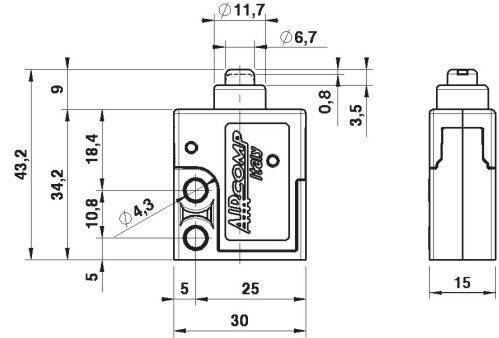

M5 VERSION

AIR PREPARATION

VALVES

CYLINDERS

FITTINGS

WATER PREPARATION

PUSHROD MICROVALVES WITH SIDE PORTS



	CODE	REFERENCES
	1000412101 1000492101	MV ML5 15 2 PU ML NC P MV AL4 15 2 PU ML NC P
	1000413101 1000493101	MV ML5 15 3 PU ML NC P MV AL4 15 3 PU ML NC P
	1000413102 1000493102	MV ML5 15 3 PU ML NO P MV AL4 15 3 PU ML NO P

TECHNICAL DATA

Thrust force (a 6 Bar) 8 N

Weight 0,024 kg

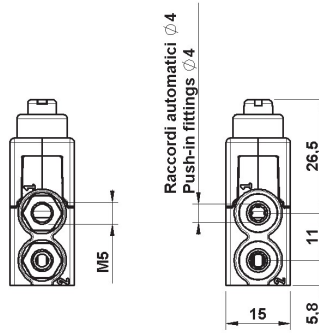

ML5 VERSION

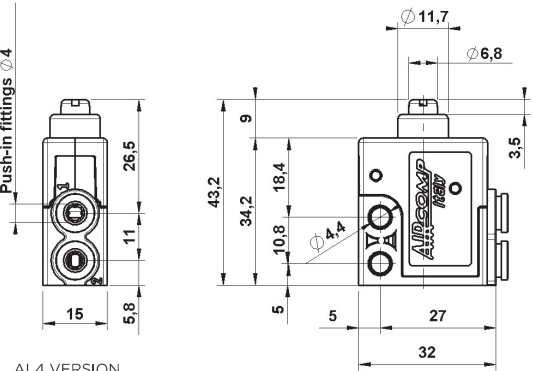

AL4 VERSION

LINE 120 ME | MECHANICAL VALVES

AIR PREPARATION

VALVES



CYLINDERS

FITTINGS

WATER PREPARATION

GENERAL FEATURES

Construction	spool valve
Body size	22mm
Body material	technopolymer
Single use	YES
Manifold use	NO
Available functions	3/2; 5/2; 5/3

GENERAL TECHNICAL DATA

Fluid	filtered air with or without lubrication
Connections	1/8"
Temperature Range	-5 / +50°C (23 / 122°F) Please note: Below 3°C the air of the circuit must be free from humidity
Reference Flow Rate	P1= 6 bar; Δ P= 1 bar; 5/2= 670 (l/min), 5/3= 550 (l/min), 3/2= 690 l/min

GUIDE TO REFERENCES

ME 1/8" 22 3 PU ML NC P

Product	ME = Mechanical valves	Material	P = Technopolymer
Connection	1/8" = G1/8"	Option	NC = Normally closed NO = Normally opened CC = Closed centres CA = Opened centres CA = Pressure centre OO = 5/2
Size	22 = 22 mm	Return	ML = Spring BS = Bistable ST = Stable on 3 position RC = Return to centre MP = Pneumatic spring
Function	3 = 3/2 5 = 5/2 6 = 5/3	Operation	PU = Pushrod PP = through-wall pushrod RL = Roller lever RU = Unidirectional roller lever PS = Sensible pushrod PO = Sensible through-wall pushrod RS = Sensible roller lever RO = Sensible unidirectional roller lever AN = Whisker RLC = Roller lever whit ball bearing RUC = Unidirectional roller lever whit ball bearing

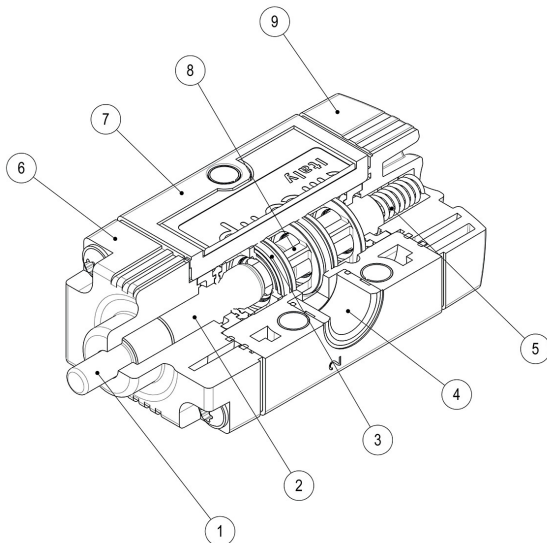

USED MATERIALS

1. **Pushrod** - Steel
2. **Spool** - Nickel Plated Aluminium
3. **Seals** - NBR
4. **Insert** - Brass
5. **Spring** - Stainless steel
6. **Operator body** - POM
7. **Body valve** - POM
8. **Spacers** - Brass
9. **Base command** - PA+FV

LINE 120 ME 1/8" | MECHANICAL VALVES

3/2 PUSHROD VALVES



	CODE	REFERENCES
	1202423001	ME 1/8" 22 3 PU ML NC P
	1202423002	ME 1/8" 22 3 PU ML NO P

TECHNICAL DATA

Working pressure 0÷10 Bar (0÷1,00 MPa)

Thrust force (a 6 Bar) 39 N

Weight 0,060 kg

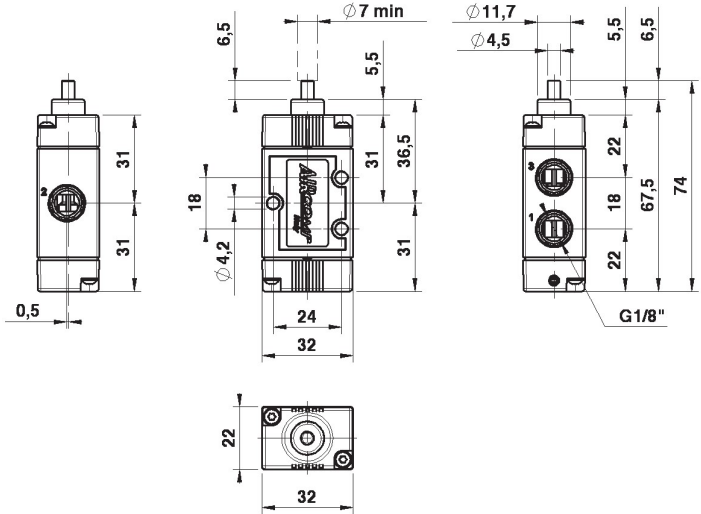

AIR PREPARATION

VALVES

CYLINDERS

FITTINGS

WATER PREPARATION

5/2 PUSHROD VALVES



	CODE	REFERENCES
	1202425001	ME 1/8" 22 5 PU ML OO P

TECHNICAL DATA

Working pressure 0÷10 Bar (0÷1,00 MPa)

Thrust force (a 6 Bar) 39 N

Weight 0,067 kg

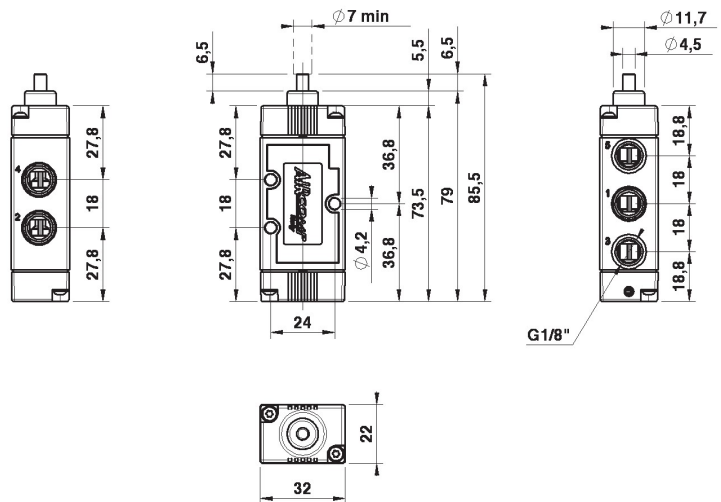

LINE 120 ME 1/8" | MECHANICAL VALVES

AIR PREPARATION

VALVES

3/2 ROLLER LEVER VALVES



VERSION WITH TECHNOPOLYMER ROLLER

CODE	REFERENCES
 1202423003	ME 1/8" 22 3 RL ML NC P

 1202423004	ME 1/8" 22 3 RL ML NO P
--	-------------------------

BALL BEARING VERSION

CODE	REFERENCES
 1202423007	ME1/8 22 3 RLC ML NC P

 1202423008	ME1/8 22 3 RLC ML NO P
--	------------------------

TECHNICAL DATA

Working pressure 1+10 Bar (0+1,00 MPa)

Thrust force (a 6 Bar) 16 N

Weight 0,085 kg

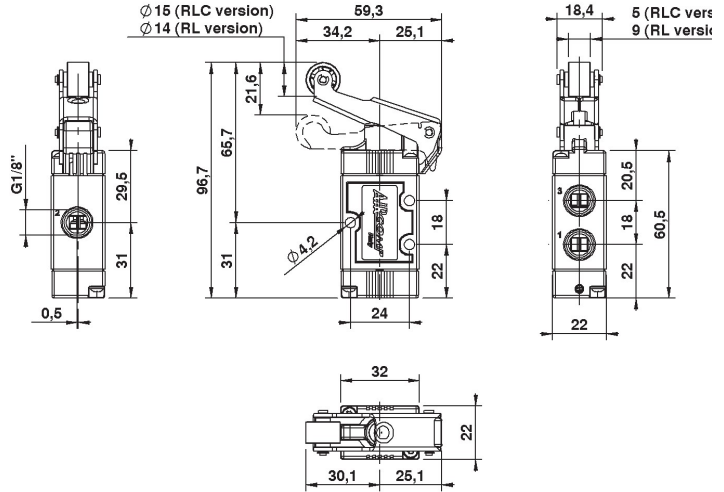

CYLINDERS

FITTINGS

WATER PREPARATION

5/2 ROLLER LEVER VALVES



VERSION WITH TECHNOPOLYMER ROLLER

CODE	REFERENCES
 1202425002	ME 1/8" 22 5 RL ML OO P

VERSION WITH BALL BEARING

CODE	REFERENCES
 1202425006	ME1/8 22 5 RLC ML OO P

TECHNICAL DATA

Working pressure 0+10 Bar (0+1,00 MPa)

Thrust force (a 6 Bar) 16 N

Weight 0,092 kg

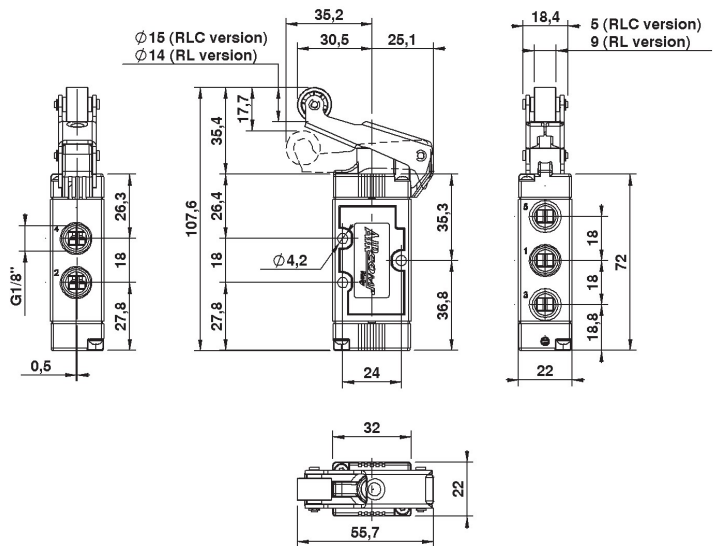

LINE 120 ME 1/8" | MECHANICAL VALVES

3/2 UNIDIRECTIONAL ROLLER LEVER VALVES

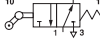

VERSION WITH TECHNOPOLYMER ROLLER

CODE	REFERENCES
 1202423005	ME 1/8" 22 3 RU ML NC P
 1202423006	ME 1/8" 22 3 RU ML NO P

VERSION WITH BALL BEARING.

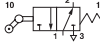
CODE	REFERENCES
 1202423009	ME1/8 22 3 RUC ML NC P
 1202423010	ME1/8 22 3 RUC ML NO P

TECHNICAL DATA

Working pressure 0÷10 Bar (0÷1,00 MPa)

Thrust force (a 6 Bar) 18 N

Weight 0,092 kg

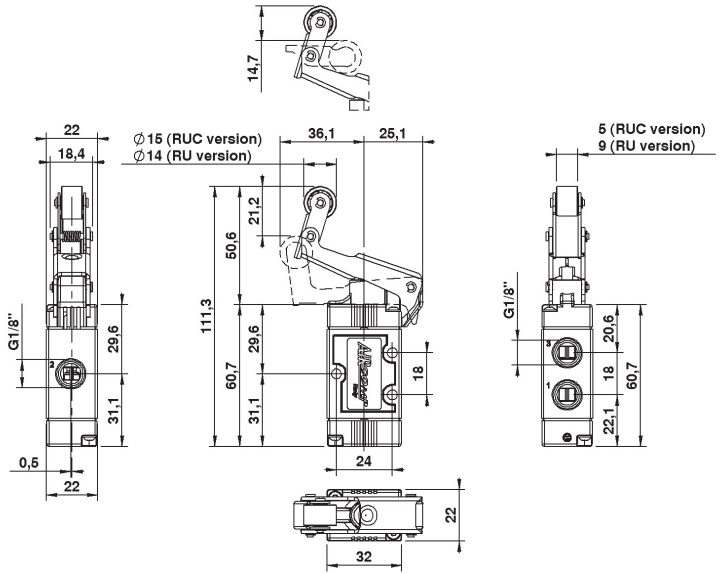

5/2 UNIDIRECTIONAL ROLLER LEVER VALVES



VERSION WITH TECHNOPOLYMER ROLLER

CODE	REFERENCES
 1202425003	ME 1/8" 22 5 RU ML OO P

VERSION WITH BALL BEARING

CODE	REFERENCES
 1202425007	ME1/8 22 5 RUC ML OO P

TECHNICAL DATA

Working pressure 0÷10 Bar (0÷1,00 MPa)

Thrust force (a 6 Bar) 16 N

Weight 0,098 kg

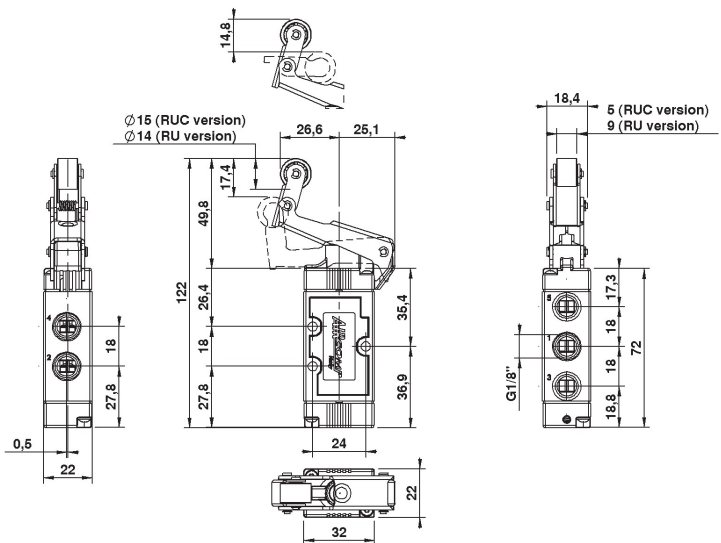

AIR PREPARATION

VALVES

CYLINDERS

FITTINGS

WATER PREPARATION

LINE 120 ME 1/8" | MECHANICAL VALVES

AIR PREPARATION

VALVES

3/2 SENSIBLE PUSHROD VALVES



	CODE	REFERENCES
	1202523001	ME 1/8" 22 3 PS PM NC P
	1202523002	ME 1/8" 22 3 PS PM NO P

TECHNICAL DATA

Working pressure 1±10 Bar (0,10±1,00 MPa)

Thrust force (a 6 Bar) 9 N

Weight 0,072 kg

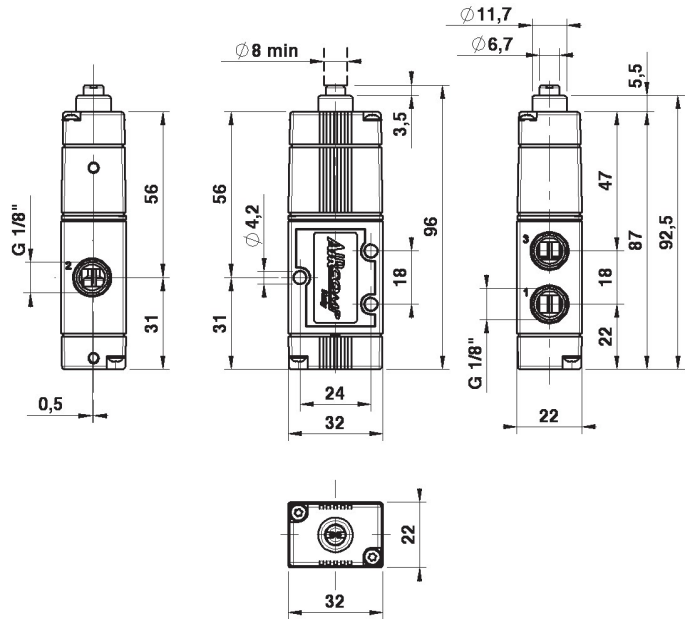

CYLINDERS

FITTINGS

WATER PREPARATION

5/2 SENSIBLE PUSHROD VALVES



	CODE	REFERENCES
	1202525001	ME 1/8" 22 5 PS PM OO P

TECHNICAL DATA

Working pressure 1±10 Bar (0,01±1,00 MPa)

Thrust force (a 6 Bar) 9 N

Weight 0,079 kg

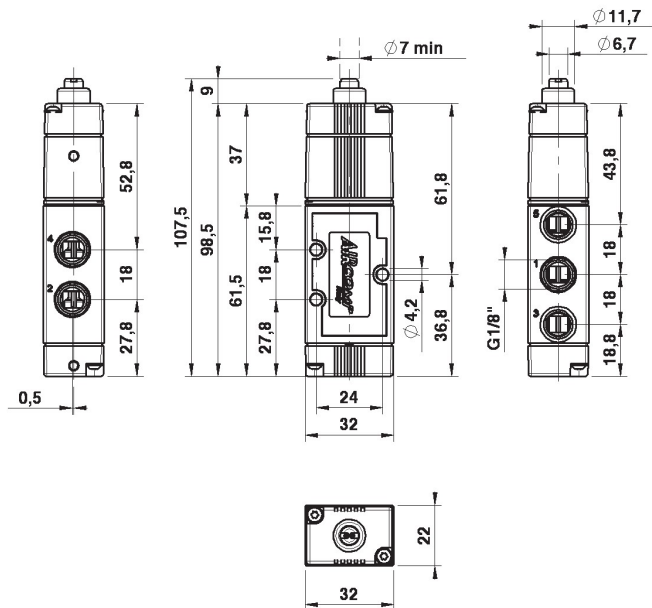

LINE 120 ME 1/8" | MECHANICAL VALVES

3/2 SENSIBLE THROUGH-WALL PUSHROD VALVES



	CODE	REFERENCES
	1202523007	ME 1/8" 22 3 PO PM NC P
	1202523008	ME 1/8" 22 3 PO PM NO P

TECHNICAL DATA

Working pressure 1±10 Bar (0,10±1,00 MPa)

Thrust force (a 6 Bar) 9 N

Weight 0,075 kg

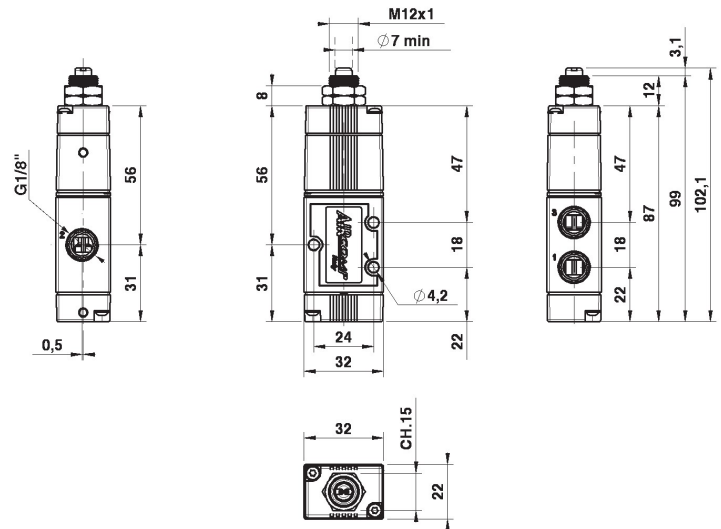

AIR PREPARATION

VALVES

CYLINDERS

FITTINGS

WATER PREPARATION

5/2 SENSIBLE THROUGH-WALL PUSHROD VALVES



	CODE	REFERENCES
	1202525004	ME 1/8" 22 5 PO PM OO P

TECHNICAL DATA

Working pressure 1±10 Bar (0,10±1,00 MPa)

Thrust force (a 6 Bar) 9 N

Weight 0,082 kg

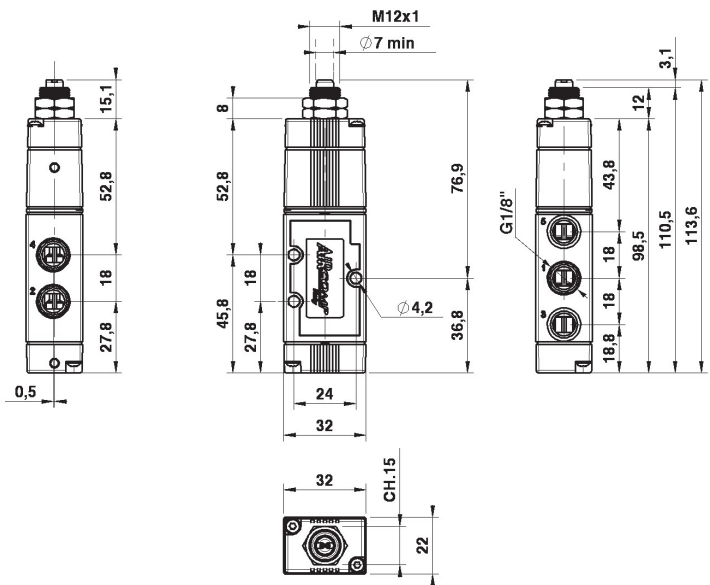

FITTINGS

WATER PREPARATION

LINE 120 ME 1/8" | MECHANICAL VALVES

AIR PREPARATION

VALVES

3/2 SENSIBLE ROLLER LEVER VALVES



	CODE	REFERENCES
	1202523003	ME 1/8" 22 3 RS PM NC P
	1202523004	ME 1/8" 22 3 RS PM NO P

TECHNICAL DATA

Working pressure 1÷10 Bar (0,01÷1,00 MPa)

Thrust force (a 6 Bar) 4,5 N

Weight 0,079 kg

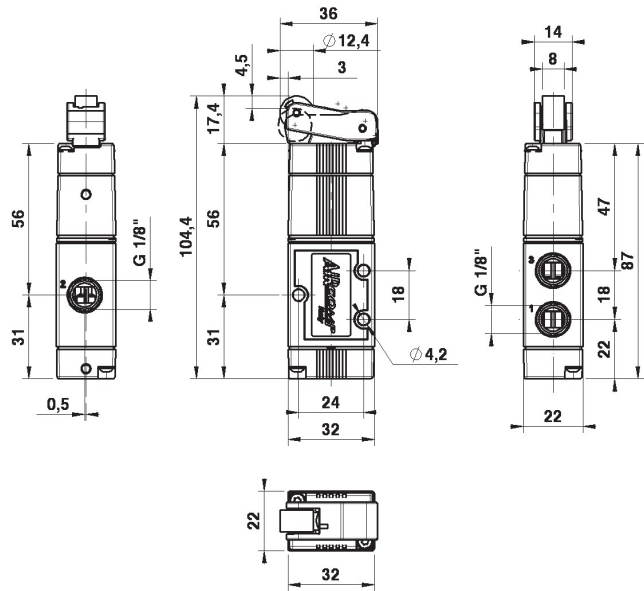

CYLINDERS

5/2 SENSIBLE ROLLER LEVER VALVES



	CODE	REFERENCES
	1202525002	ME 1/8" 22 5 RS PM OO P

TECHNICAL DATA

Working pressure 1÷10 Bar (0,10÷1,00 MPa)

Thrust force (a 6 Bar) 4,5 N

Weight 0,086 kg

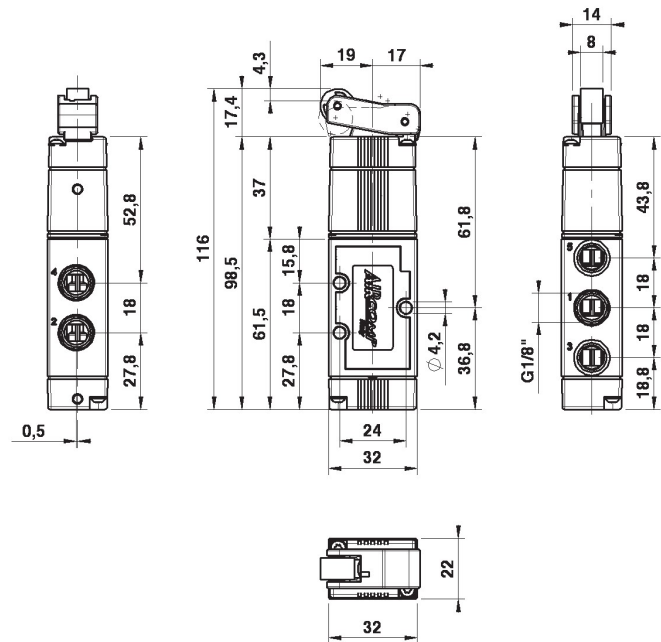

FITTINGS

WATER PREPARATION

LINE 120 ME 1/8" | MECHANICAL VALVES

AIR PREPARATION

VALVES

3/2 WHISKER VALVES



	CODE	REFERENCES
	1202523013	ME 1/8" 22 3 AN PM NC P
	1202523014	ME 1/8" 22 3 AN PM NO P

TECHNICAL DATA

Working pressure 1±10 Bar (0,10±1,00 MPa)

Weight 0,078 kg

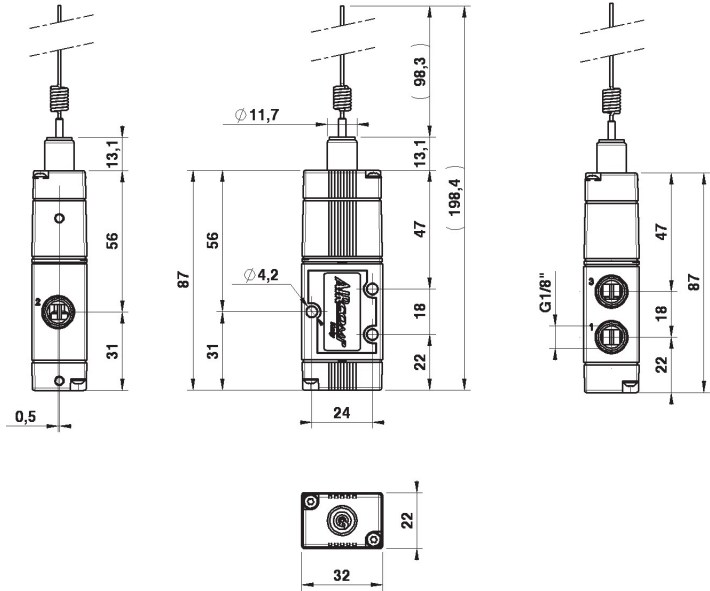

CYLINDERS

FITTINGS

WATER PREPARATION

5/2 WHISKER VALVES



	CODE	REFERENCES
	1202525007	ME 1/8" 22 5 AN PM OO P

TECHNICAL DATA

Working pressure 1±10 Bar (0,10±1,00 MPa)

Weight 0,085 kg

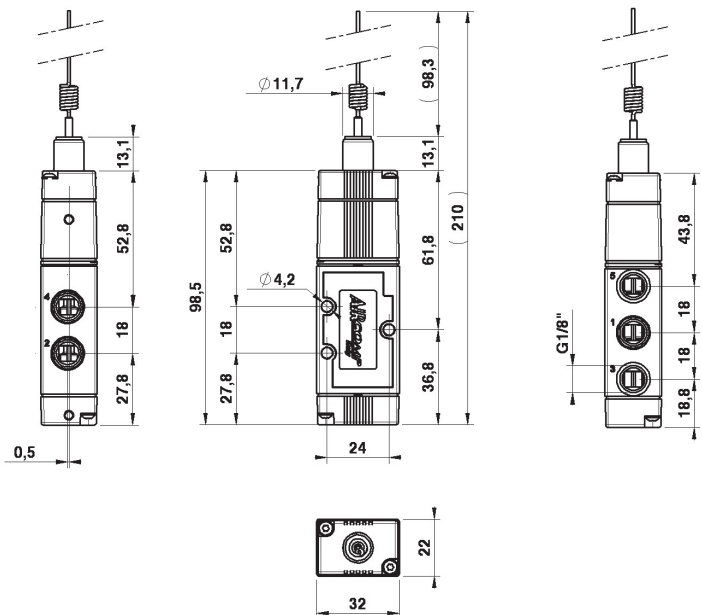

LINE 127 MER | MECHANICAL VALVES



AIR PREPARATION

VALVES

CYLINDERS

FITTINGS

WATER PREPARATION

GENERAL FEATURES

Construction	spool valve
Body size	22mm
Body material	aluminium
Single use	YES
Manifold use	YES
Available functions	3/2; 5/2; 5/3

GENERAL TECHNICAL DATA

Fluid	filtered air with or without lubrication
Connections	1/8" - 1/4"
Temperature Range	-5 / +50°C (23 / 122°F) Please note: Below 3°C the air of the circuit must be free from humidity
Reference Flow Rate	P1= 6 bar; Δ P= 1 bar; 5/2= 800 l/min 5/3: 750 l/min

GUIDE TO REFERENCES

MER 1/4" 22 3 PU ML NC M

Product
MER = Valvole meccaniche

Connection
1/4" = G1/4"

Size
22 = 22 mm

Function
3 = 3/2
5 = 5/2
6 = 5/3

Material
M = Metal

Option
NC = Normally closed
NO = Normally opened
CC = Closed centres
CA = Opened centres
CP = Pressure centre
OO = 5/2

Return
ML = Spring
BS = Bistable
ST = Stable on 3 position
RC = Return to centre
MP = Pneumatic spring

Operation
PU = Pushrod
PP = Through-wall pushrod
RL = Roller lever
RU = Unidirectional roller lever
PS = Sensible pushrod
PO = Sensible through-wall pushrod
RS = Sensible roller lever
RO = Sensible unidirectional roller lever
AN = Whisker
RLC = Roller lever whit ball bearing
RLC = Unidirectional roller lever whit ball bearing

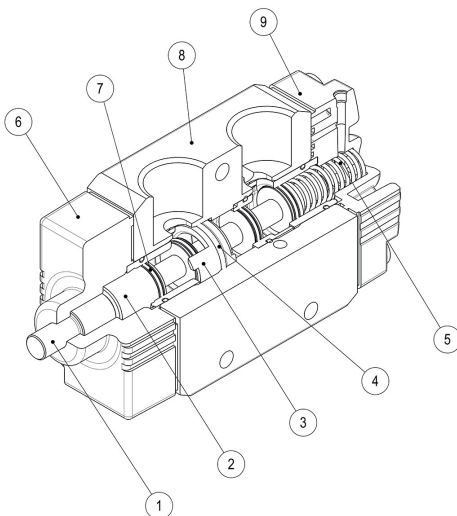

USED MATERIALS

1. Pushrod - Steel
2. Spool - Nickel Plated Aluminium
3. Spacers - POM
4. Or distanziali - NBR
5. Spring - Stainless steel
6. Operator body - POM
7. Seals - NBR
8. Body valve - Aluminium
9. Base command - PA+FV

LINE 127 MER 1/4" | MECHANICAL VALVES

AIR PREPARATION

3/2 PUSHROD VALVES



VALVES

	CODE	REFERENCES
	1272433001	MER 1/4" 22 3 PU ML NC M
	1272433002	MER 1/4" 22 3 PU ML NO M

TECHNICAL DATA

Working pressure 0÷10 Bar (0÷1,00 MPa)

Thrust force (a 6 Bar) 39 N

Weight 0,120 kg

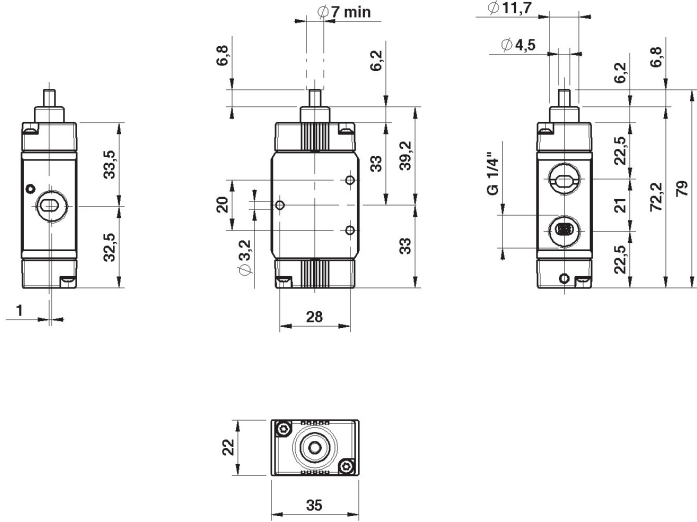

CYLINDERS

FITTINGS

5/2 PUSHROD VALVES



WATER PREPARATION

	CODE	REFERENCES
	1272435001	MER 1/4" 22 5 PU ML OO M

TECHNICAL DATA

Working pressure 0÷10 Bar (0÷1,00 MPa)

Thrust force (a 6 Bar) 39 N

Weight 0,127 kg

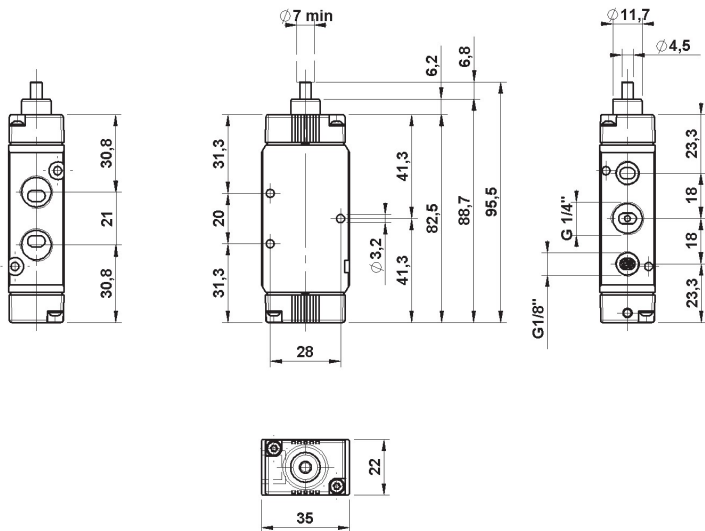

LINE 127 MER 1/4" | MECHANICAL VALVES

3/2 SENSIBLE PUSHROD VALVES



	CODE	REFERENCES
	1272533001	MER 1/4" 22 3 PS PM NC M
	1272533002	MER 1/4" 22 3 PS PM NO M

TECHNICAL DATA

Working pressure 1÷10 Bar (0,10÷1,00 MPa)
Thrust force (a 6 Bar) 9 N
Weight 0,132 kg

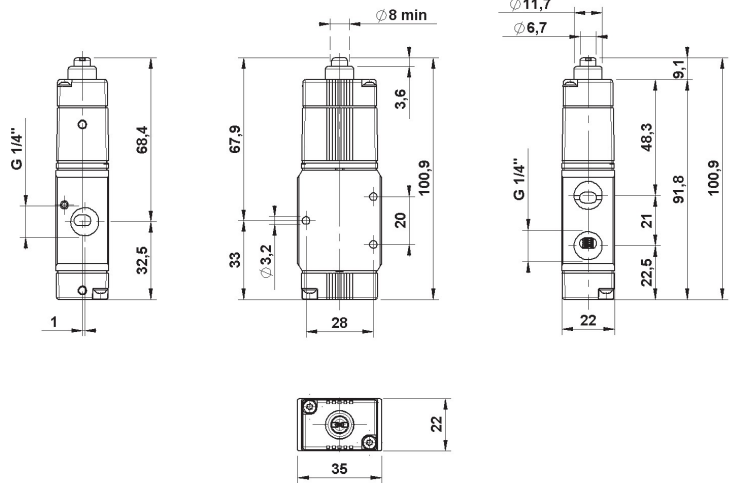

AIR PREPARATION

VALVES

CYLINDERS

FITTINGS

WATER PREPARATION

5/2 SENSIBLE PUSHROD VALVES



	CODE	REFERENCES
	1272535001	MER 1/4" 22 5 PS PM OO M

TECHNICAL DATA

Working pressure 1÷10 Bar (0,10÷1,00 MPa)
Thrust force (a 6 Bar) 9 N
Weight 0,139 kg

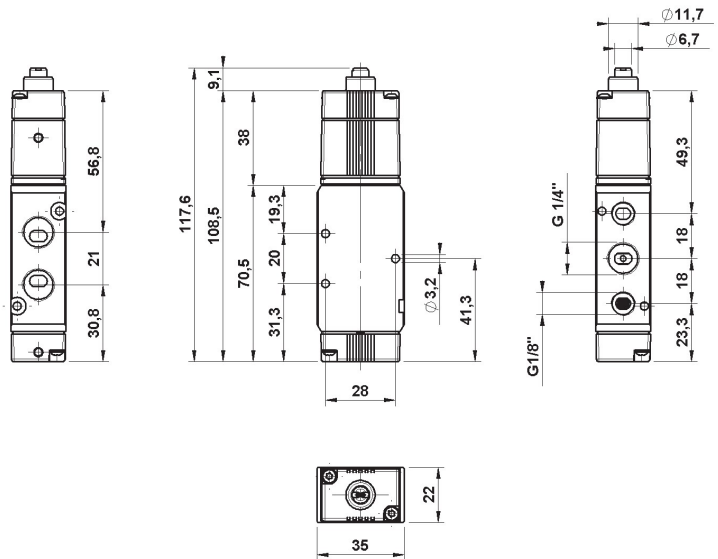

LINE 127 MER 1/4" | MECHANICAL VALVES

AIR PREPARATION

VALVES

3/2 SENSIBLE THROUGH PUSHROD VALVES



	CODE	REFERENCES
	1272533007	MER 1/4" 22 3 PO PM NC M
	1272533008	MER 1/4" 22 3 PO PM NO M

TECHNICAL DATA

Working pressure 1+10 Bar (0,10+1,00 MPa)

Thrust force (a 6 Bar) 9 N

Weight 0,135 kg

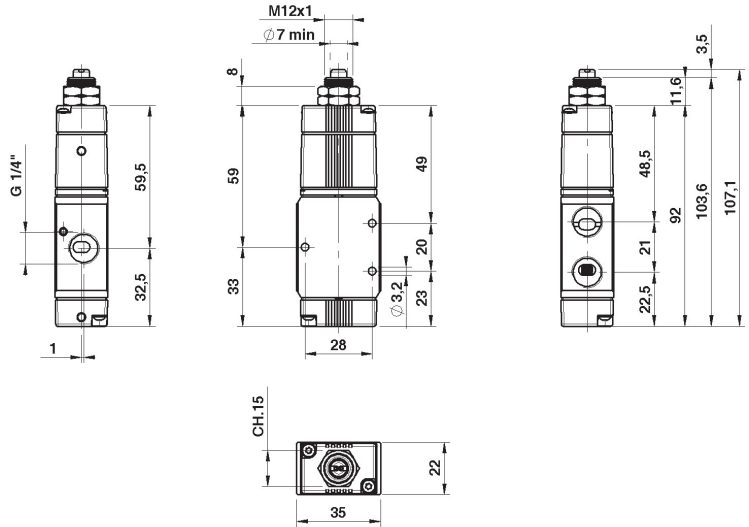

CYLINDERS

FITTINGS

5/2 SENSIBLE THROUGH PUSHROD VALVES



	CODE	REFERENCES
	1272535004	MER 1/4" 22 5 PO PM OO M

TECHNICAL DATA

Working pressure 1+10 Bar (0,10+1,00 MPa)

Thrust force (a 6 Bar) 9 N

Weight 0,142 kg

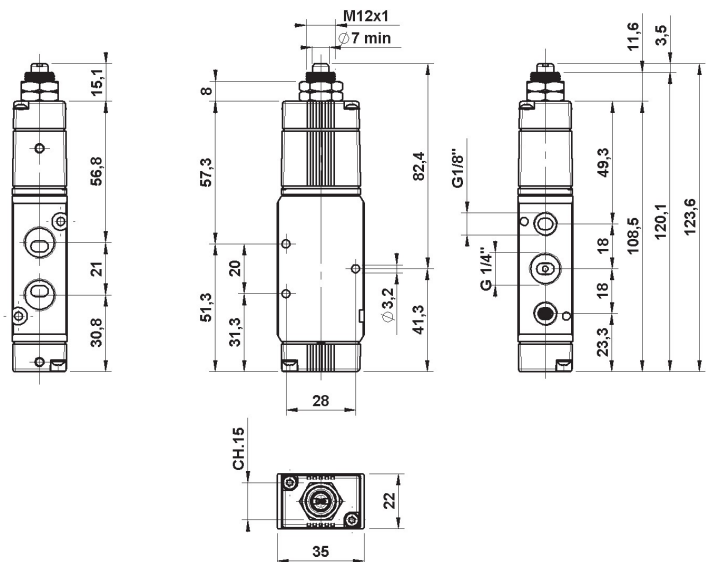



WATER PREPARATION

LINE 127 MER 1/4" | MECHANICAL VALVES



3/2 ROLLER LEVER VALVES



VERSION WITH TECHNOPOLYMER ROLLER

CODE	REFERENCES
 1272433003	MER 1/4" 22 3 RL ML NC M
 1272433004	MER 1/4" 22 3 RL ML NO M

VERSION WITH BALL BEARING

CODE	REFERENCES
 1272433007	MER 1/4 22 3 RLC ML NC M
 1272433008	MER 1/4 22 3 RLC ML NO M

TECHNICAL DATA

Working pressure 0÷10 Bar (0÷1,00 MPa)

Thrust force (a 6 Bar) 16 N

Weight 0,145 kg

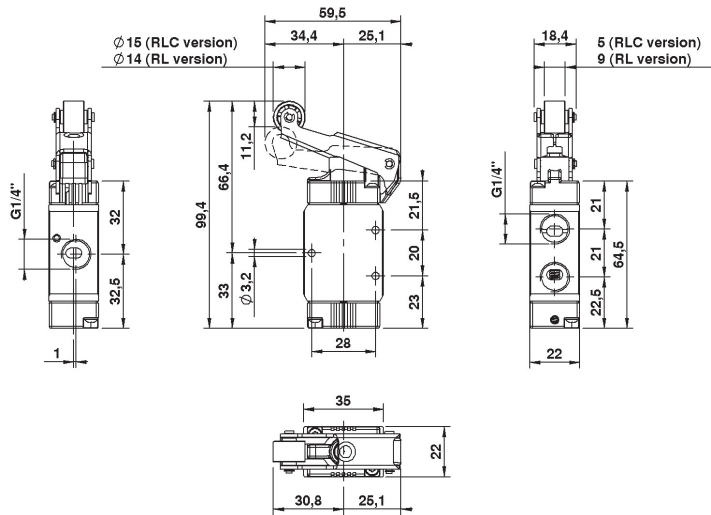

5/2 ROLLER LEVER VALVE



VERSION WITH TECHNOPOLYMER ROLLER

CODE	REFERENCES
 1272435002	MER 1/4" 22 5 RL ML NO M

VERSION WITH BALL BEARING

CODE	REFERENCES
 1272435006	MER 1/4 22 5 RLC ML OO M

TECHNICAL DATA

Working pressure 0÷10 Bar (0÷1,00 MPa)

Thrust force (a 6 Bar) 16 N

Weight 0,152 kg

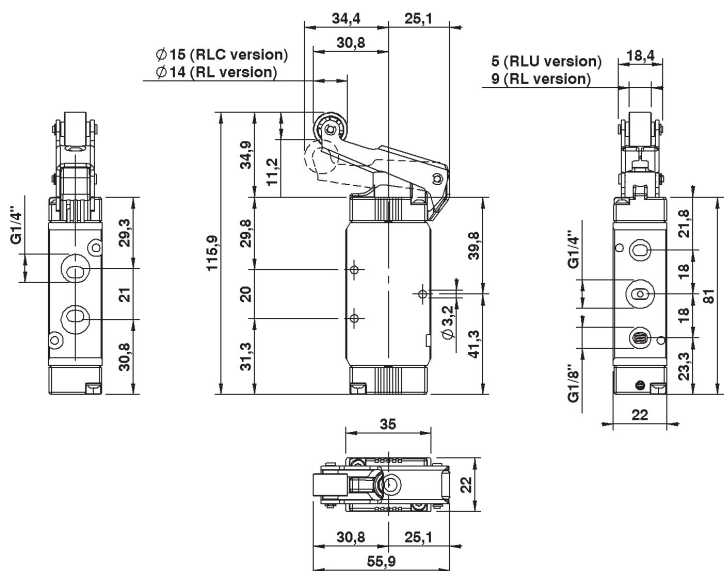

AIR PREPARATION

VALVES

CYLINDERS

FITTINGS

WATER PREPARATION

LINE 127 MER 1/4" | MECHANICAL VALVES

AIR PREPARATION

VALVES

3/2 UNIDIRECTIONAL ROLLER LEVER VALVES

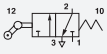

VERSION WITH TECHNOPOLYMER ROLLER

CODE	REFERENCES
 1272433005	MER 1/4" 22 3 RU ML NC M

 1272433006	MER 1/4" 22 3 RU ML NO M
--	--------------------------

VERSION WITH BALL BEARING

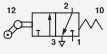
CODE	REFERENCES
 1272433009	MER 1/4 22 3 RUC ML NC M

 1272433010	MER 1/4 22 3 RUC ML NO M
--	--------------------------

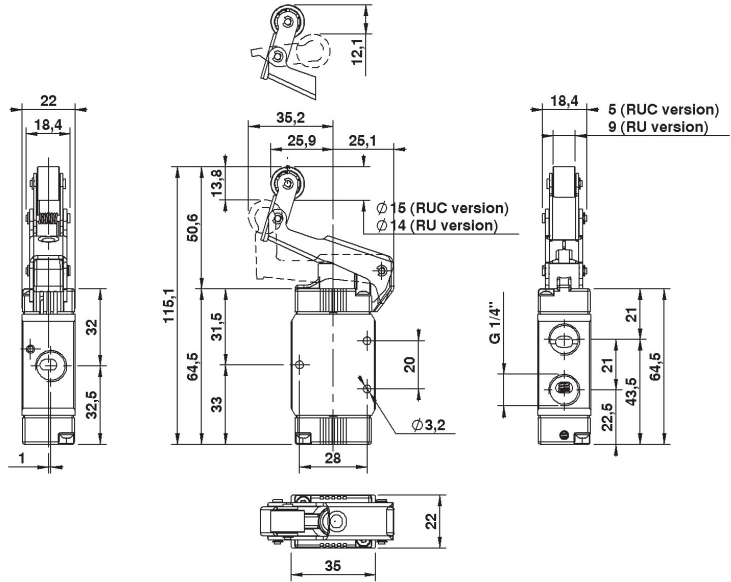

CYLINDERS

FITTINGS

TECHNICAL DATA

Working pressure 0÷10 Bar (0÷1,00 MPa)

Thrust force (a 6 Bar) 16 N

Weight 0,152 kg

WATER PREPARATION

5/2 UNIDIRECTIONAL ROLLER LEVER VALVE

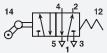

VERSION WITH TECHNOPOLYMER ROLLER

CODE	REFERENCES
 1272435003	MER 1/4" 22 5 RU ML OO M

VERSION WITH BALL BEARING

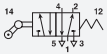
CODE	REFERENCES
 1272435007	MER 1/4 22 5 RUC ML OO M

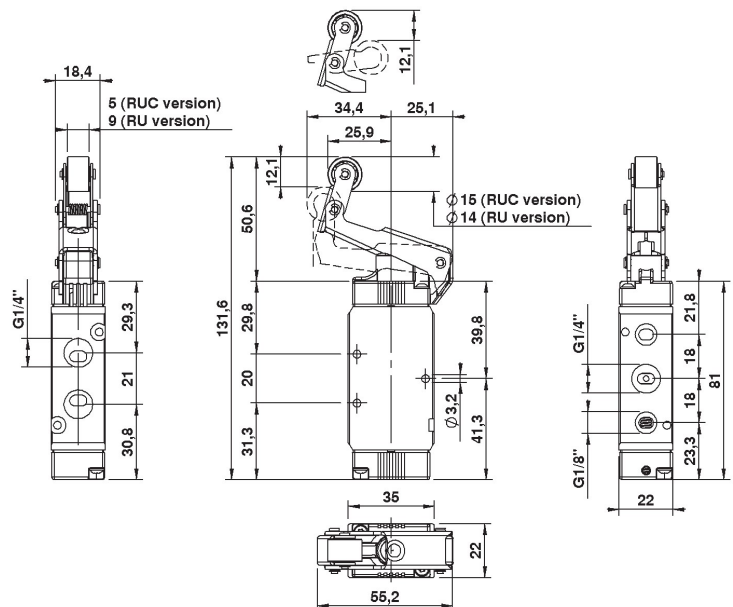

TECHNICAL DATA

Working pressure 0÷10 Bar (0÷1,00 MPa)

Thrust force (a 6 Bar) 16 N

Weight 0,158 kg

LINE 127 MER 1/4" | MECHANICAL VALVES

3/2 ROLLER LEVER VALVE



	CODE	REFERENCES
	1272533003	MER 1/4" 22 3 RS PM NC M
	1272533004	MER 1/4" 22 3 RS PM NO M

TECHNICAL DATA

Working pressure 1±10 Bar (0,10±1,00 MPa)

Thrust force (a 6 Bar) 4,5 N

Weight 0,149 kg

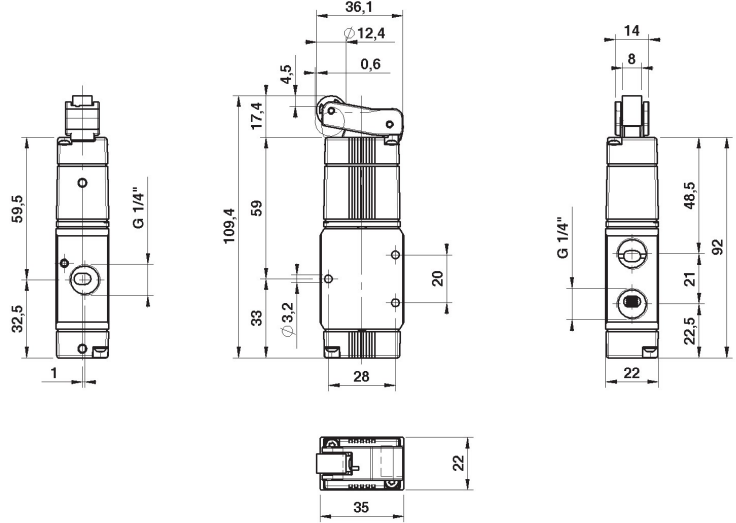

AIR PREPARATION

VALVES

CYLINDERS

FITTINGS

WATER PREPARATION

5/2 SENSIBLE ROLLER LEVER VALVES



	CODE	REFERENCES
	1272535002	MER 1/4" 22 5 RS PM OO M

TECHNICAL DATA

Working pressure 1±10 Bar (0,10±1,00 MPa)

Thrust force (a 6 Bar) 4,5 N

Weight 0,146 kg

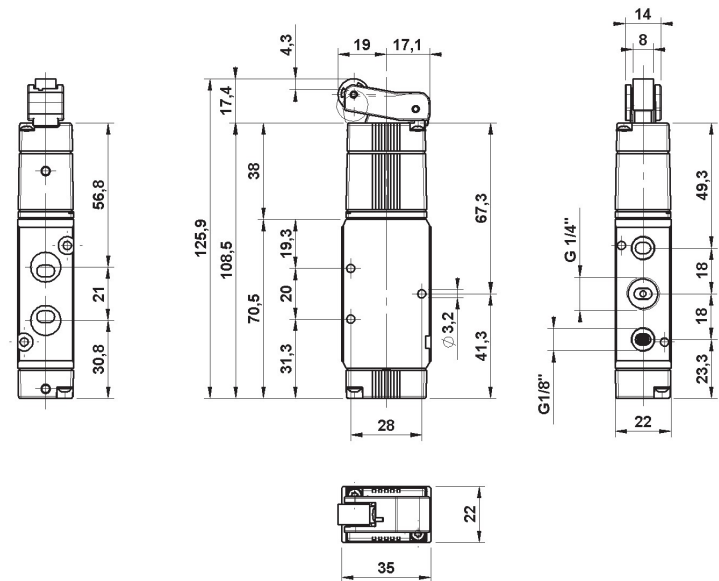

FITTINGS

WATER PREPARATION

LINE 127 MER 1/4" | MECHANICAL VALVES

AIR PREPARATION

VALVES



	CODE	REFERENCES
	1272533005	MER 1/4" 22 3 RO PM NC M

	1272533006	MER 1/4" 22 3 RO PM NO M
--	------------	--------------------------

TECHNICAL DATA

Working pressure 1÷10 Bar (0,10÷1,00 MPa)

Thrust force (a 6 Bar) 16 N

Weight 0,142 kg

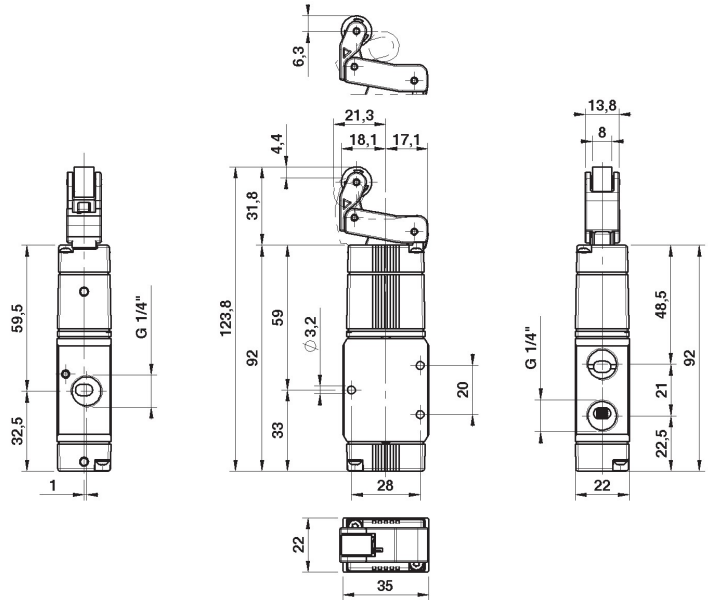

CYLINDERS

FITTINGS

5/2 SENSIBLE UNIDIRECTIONAL ROLLER LEVER VALVE

WATER PREPARATION



	CODE	REFERENCES
	1272535003	MER 1/4" 22 5 RO PM OO M

TECHNICAL DATA

Working pressure 1÷10 Bar (0,10÷1,00 MPa)

Thrust force (a 6 Bar) 4,5 N

Weight 0,149 kg

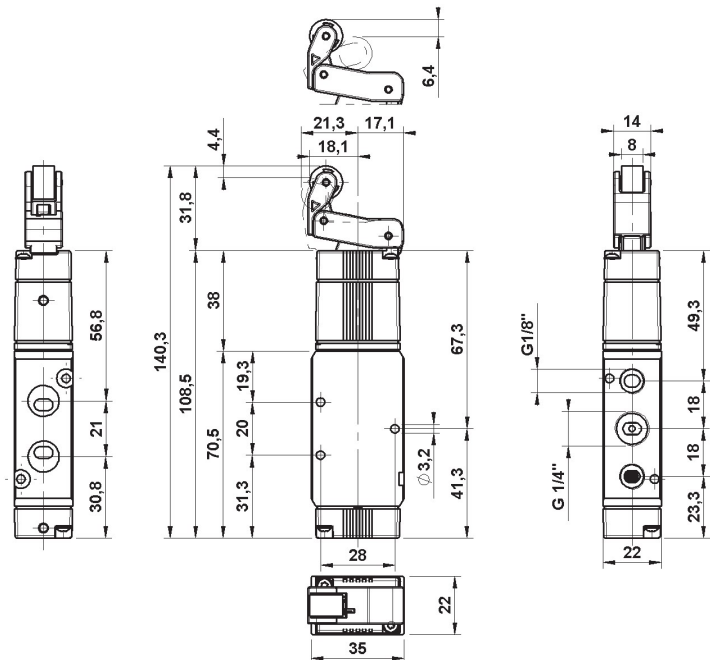

LINE 127 MER 1/4" | MECHANICAL VALVES

3/2 WHISKER VALVES



	CODE	REFERENCES
	1272533013	MER 1/4" 22 3 AN PM NC M
	1272533014	MER 1/4" 22 3 AN PM NO M

TECHNICAL DATA

Working pressure 1±10 Bar (0,10±1,00 MPa)

Weight 0,138 kg

N.B. On request is available whisker version provided whit threaded rod and fixing nuts

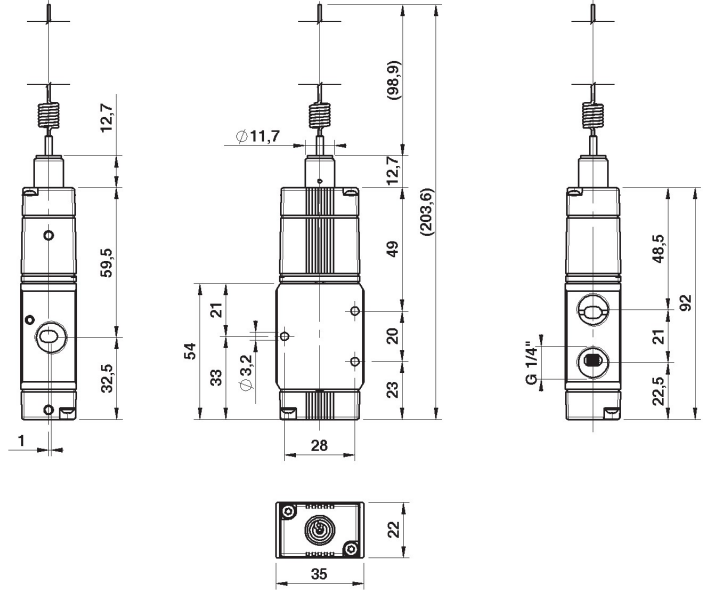

5/2 WHISKER VALVES



	CODE	REFERENCES
	1272535007	MER 1/4" 22 5 AN PM OO M

TECHNICAL DATA

Working pressure 1±10 Bar (0,10±1,00 MPa)

Weight 0,145 kg

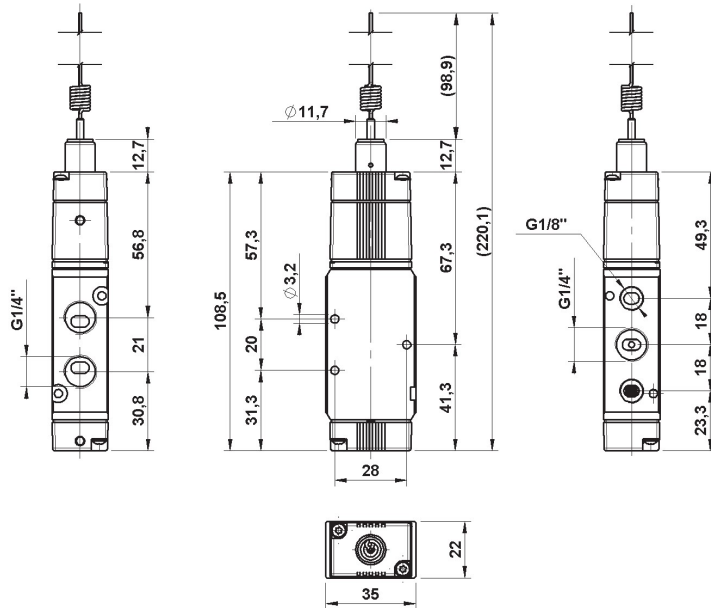

AIR PREPARATION

VALVES

CYLINDERS

FITTINGS

WATER PREPARATION

LINE 140 | PEDAL VALVES

AIR PREPARATION

VALVES

CYLINDERS

FITTINGS

WATER PREPARATION



GUIDE TO REFERENCES

P140 G 1/4 5 B PP

Product P140 = Pedal valves line 140	Option PP = Guarded SP = Not guarded
Type G = Pedal M = Micropedal	Option B = Bistable M = Monostable S = Monostable with safety device
Connection 1/4 = G1/4" M5 = M5 AU4 = ø4mm push-in fitting EL = Electric	Function 3 = 3/2 NC 5 = 5/2 0 = Microswitch NC-NO

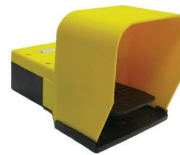

PNEUMATIC PEDAL VALVE TECHNICAL DATA

Reference	P140 M __	P140 G AU4 __	P140 G 1/4 __
Connection	Push-in 4 mm - M5	Push-in 4mm	G1/4"
Fluid	filtered air with or without lubrication		
Construction	poppet valve	poppet valve	spool valve
Reference Flow Rate (P= 6bar; p= 1bar)	75 NI/min	75 NI/min	550 NI/min
Working pressure	2 ÷ 10 bar (0,20÷ 1,0 Mpa)		
Temperature Range	-10° / 50°C (14 / 122 °F)		
Weight	0,165 Kg	0,80 Kg	0,95 Kg

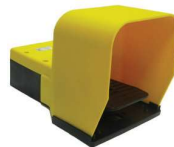

ELECTRICAL PEDAL VALVE TECHNICAL DATA

Reference	P140 G EL 0 M PP	P140 G __
Construction	Single microswitch nc+no	Monostable with safety system
Type	Monostable	Monostable with safety system
Temperature Range	-25° / 70°C (-13 / 158°F)	
Voltage (V)	max 230V AC	
Electrical Rated Current Ith (A)	10 A	
Reference rule (electric contact only)	IEC 60947 -5 -1 A600 Q300	
Weight	0,76 Kg	0,76 Kg

LINE 140 | PEDAL VALVES

5/2 G1/4" - 3/2 Ø4, GUARDED PEDAL VALVES



CODE	REFERENCES
1407493001	P140 G AU4 3 M PP
1407493002	P140 G AU4 3 S PP
1407493003	P140 G AU4 3 B PP
1407535001	P140 G 1/4 5 M PP YELLOW
1407535007	P140 G 1/4 5 M PP ORANGE
1407535002	P140 G 1/4 5 S PP YELLOW
1407535008	P140 G 1/4 5 S PP ORANGE

1407535003	P140 G 1/4 5 B PP YELLOW
1407535009	P140 G 1/4 5 B PP ORANGE

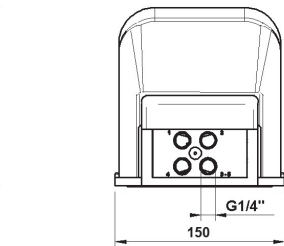
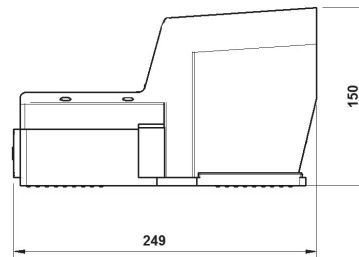

Raccordi automatici Ø4
Push-in fittings Ø4

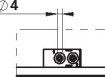

AIR PREPARATION

VALVES

CYLINDERS

FITTINGS

WATER PREPARATION

GUARDED ELECTRIC PEDAL VALVES

CODE	REFERENCES
1407660801	P140 G EL O M PP
1407660802	P140 G EL O S PP
1499A00005	IP 65 Cable nut

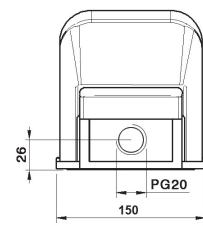
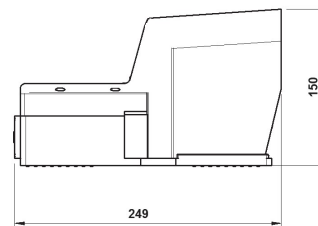

5/2 G1/4", NOT GUARDED PEDAL VALVES



CODE	REFERENCES
1407535004	P140 G 1/4 5 M SP
1407535005	P140 G 1/4 5 B SP

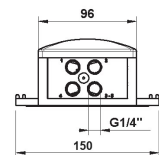
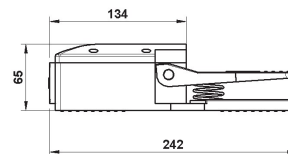

3/2 Ø4 - M5 MICROPEDAL VALVES



CODE	REFERENCES
1406493001	P140 M AU4 3 M SP
1406413001	P140 M M5 3 M SP

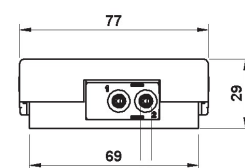
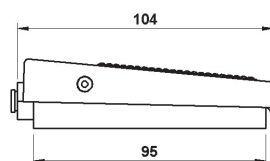

Raccordi automatici o4 / M5
Push-in fittings o4 / M5